

## Quad, 14-Bit, High-Accuracy, $\pm 16V$ Output, Serial Input DIGITAL-TO-ANALOG CONVERTER

### FEATURES

- **Bipolar Output: Up to  $\pm 16V$**
- **Unipolar Output: 0V to +20V**
- **14-Bit Monotonic**
- **Relative Accuracy: 0.5 LSB Max**
  - Before User Calibration: 1 LSB
  - After User Calibration: 0.031 LSB Zero Error, 0.25 LSB Gain Error
- **Low Noise:  $60nV/\sqrt{Hz}$**
- **Settling Time: 6 $\mu s$**
- **Configurable Gain: x2/x4**
- **Analog Output Monitor**
- **Power-Down Mode**
- **SPI™: Up to 50MHz, 1.8V/3V/5V Logic**
- **Daisy-Chain Mode**
- **Operating Temperature:  $-40^{\circ}C$  to  $+105^{\circ}C$**
- **Packages: QFN-40 (6x6mm), TQFP-48 (7x7mm)**

### APPLICATIONS

- **Automatic Test Equipment**
- **Instrumentation**
- **Industrial Process Control**
- **Communications**

### DESCRIPTION

The DAC8234 is a high-accuracy, quad-channel, 14-bit digital-to-analog converter (DAC) that operates from supply voltages of  $\pm 5V$  to  $\pm 18V$  in bipolar output mode, and from  $\pm 5V$  to  $+24V/-12V$  in unipolar mode. With a 5V reference, the DAC8234 can be configured to output  $\pm 10V$ ,  $\pm 5V$ , 0V to 20V, or 0V to 10V. The DAC8234 provides 14-bit monotonicity, excellent integral nonlinearity (INL) error of  $\pm 0.5$  LSB, low glitch, and low noise over the operating temperature range of  $-40^{\circ}C$  to  $+105^{\circ}C$ . This device is trimmed in production for very low zero and gain errors. In addition, the DAC8234 implements a user-programmable system-level calibration function to achieve  $\pm 0.031$  LSB zero error and  $\pm 0.25$  LSB gain error.

The DAC8234 has integrated reference buffers and output buffers. It features a standard high-speed 1.8V, 3V, or 5V serial peripheral interface (SPI) that operates at clock rates of up to 50MHz to communicate with a DSP or microprocessor. The four DAC channels and the auxiliary registers are addressed with four address bits. The device features double-buffered interface logic for simultaneous updates of all DACs. An asynchronous load input (LDAC) transfers data from the input data register to the DAC latch, and the contents of the DAC latch set the output voltage. The asynchronous  $\overline{RST}$  input sets the output of all four DACs to 0V. The  $V_{MON}$  pin is an analog monitor output that multiplexes the individual DAC outputs or the AIN pin.

The DAC8234 is pin-compatible with the DAC8734 (16-bit) and the DAC7716 (12-bit).

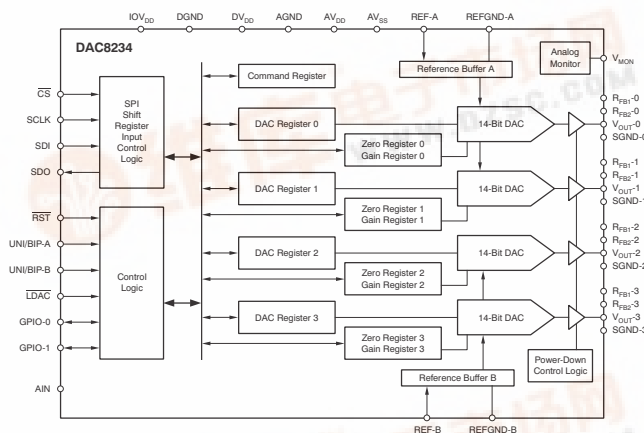

Please be aware that an important notice concerning availability, standard warranty, and use in critical applications of Texas Instruments semiconductor products and disclaimers thereto appears at the end of this data sheet.

DSP is a trademark of Texas Instruments.  
SPI, QSPI are trademarks of Motorola Inc.  
Microwire is a trademark of National Semiconductor.  
All other trademarks are the property of their respective owners.

PRODUCTION DATA information is current as of publication date. Products conform to specifications per the terms of the Texas Instruments standard warranty. Production processing does not necessarily include testing of all parameters.





This integrated circuit can be damaged by ESD. Texas Instruments recommends that all integrated circuits be handled with appropriate precautions. Failure to observe proper handling and installation procedures can cause damage.

ESD damage can range from subtle performance degradation to complete device failure. Precision integrated circuits may be more susceptible to damage because very small parametric changes could cause the device not to meet its published specifications.

### PACKAGE/ORDERING INFORMATION<sup>(1)</sup>

PRODUCT	RELATIVE ACCURACY (LSB)	DIFFERENTIAL LINEARITY (LSB)	PACKAGE-LEAD	PACKAGE DESIGNATOR	SPECIFIED TEMPERATURE RANGE	PACKAGE MARKING
DAC8234	±0.5	±0.5	QFN-40	RHA	–40°C to +105°C	DAC8234
	±0.5	±0.5	TQFP-48	PFB	–40°C to +105°C	DAC8234

(1) For the most current package and ordering information, see the Package Option Addendum at the end of this data sheet, or see the TI website at [www.ti.com](http://www.ti.com).

### ABSOLUTE MAXIMUM RATINGS<sup>(1)</sup>

Over operating free-air temperature range (unless otherwise noted).

		DAC8234	UNIT	
AV <sub>DD</sub> to AV <sub>SS</sub> <sup>(2)</sup>		–0.3 to 38	V	
AV <sub>DD</sub> to AGND <sup>(2)</sup>		–0.3 to 25	V	
AV <sub>SS</sub> to AGND, DGND <sup>(2)</sup>		–19 to 0.3	V	
DV <sub>DD</sub> to DGND		–0.3 to 6	V	
IOV <sub>DD</sub> to DGND		–0.3 to DV <sub>DD</sub> + 0.3	V	
Digital input voltage to DGND		–0.3 to IOV <sub>DD</sub> + 0.3	V	
SDO to DGND		–0.3 to IOV <sub>DD</sub> + 0.3	V	
SGND-x, REFGND-x, AGND to DGND		–0.3 to +0.3	V	
V <sub>OUT-x</sub> , R <sub>FB1-x</sub> , R <sub>FB2-x</sub> , V <sub>MON</sub> , AIN to AV <sub>SS</sub>		–0.3 to AV <sub>DD</sub> + 0.3	V	
REF-x to REFGND-x, AGND		–0.3 to min(AV <sub>DD</sub> /2, –AV <sub>SS</sub> /2)	V	
GPIO-x to DGND		–0.3 to 6	V	
GPIO-x input current		5	mA	
Operating temperature range		–40 to +105	°C	
Storage temperature range		–65 to +150	°C	
Maximum junction temperature (T <sub>J</sub> max)		+150	°C	
ESD ratings	Human body model (HBM)	4	kV	
	Charged device model (CDM)	1	kV	
Thermal impedance	Junction-to-ambient, θ <sub>JA</sub>	TQFP	57	°C/W
		QFN	32	°C/W
	Junction-to-case, θ <sub>JC</sub>	TQFP	35	°C/W
		QFN	20	°C/W
Power dissipation <sup>(3)</sup>		(T <sub>J</sub> max – T <sub>A</sub> ) / θ <sub>JA</sub>	W	

(1) Stresses above those listed under *Absolute Maximum Ratings* may cause permanent damage to the device. Exposure to absolute maximum conditions for extended periods may affect device reliability.

(2) AV<sub>SS</sub> must be < –3.5V if AV<sub>DD</sub> ≥ 1V.

(3) T<sub>A</sub> is the ambient temperature.

## ELECTRICAL CHARACTERISTICS

All specifications at  $T_A = T_{MIN}$  to  $T_{MAX}$ ,  $AV_{DD} = +11V$  to  $+18V$ ,  $AV_{SS} = -11V$  to  $-18V$ ,  $V_{REF} = REF-A = REF-B = +5V$ ,  $DV_{DD} = +5V$ ,  $IOV_{DD} = +1.8V$  to  $DV_{DD}$ ,  $AGND = DGND = REFGND-A = REFGND-B = SGND-x = 0V$ , and DAC gain = 4, unless otherwise noted.

PARAMETER	CONDITIONS	DAC8234			UNIT
		MIN	TYP	MAX	
<b>STATIC PERFORMANCE</b>					
<b>Bipolar Output</b>					
Resolution		14			Bits
Linearity error, INL				±0.5	LSB
Differential linearity error, DNL				±0.5	LSB
Bipolar zero error <sup>(1)</sup>	$T_A = +25^\circ\text{C}$ , before user calibration			±1	LSB
	$T_A = +25^\circ\text{C}$ , after user calibration <sup>(2)</sup>		±0.031		LSB
Bipolar zero error TC <sup>(2)</sup>			±0.5		ppm FSR/°C
Gain error <sup>(1)</sup>	$T_A = +25^\circ\text{C}$ , before user calibration			±1	LSB
	$T_A = +25^\circ\text{C}$ , after user calibration <sup>(2)</sup>		±0.25		LSB
Gain error TC <sup>(2)</sup>			±0.5		ppm FSR/°C
DC crosstalk <sup>(2)(3)</sup>	Output unloaded			±0.1	LSB
<b>Unipolar Output</b>					
Resolution		14			Bits
Linearity error, INL	$AV_{DD} = +21V$ , $AV_{SS} = -11V$			±0.5	LSB
Differential linearity error, DNL	$AV_{DD} = +21V$ , $AV_{SS} = -11V$			±0.5	LSB
Zero error	$AV_{DD} = +21V$ , $AV_{SS} = -11V$ , $T_A = +25^\circ\text{C}$ , before user calibration			±1	LSB
	$AV_{DD} = +21V$ , $AV_{SS} = -11V$ , $T_A = +25^\circ\text{C}$ , after user calibration <sup>(2)</sup>		±0.031		LSB
Zero error TC <sup>(2)</sup>	$AV_{DD} = +21V$ , $AV_{SS} = -11V$		±0.2		ppm FSR/°C
Gain error	$AV_{DD} = +21V$ , $AV_{SS} = -11V$ , $T_A = +25^\circ\text{C}$ , before user calibration			±1	LSB
	$AV_{DD} = +21V$ , $AV_{SS} = -11V$ , $T_A = +25^\circ\text{C}$ , after user calibration <sup>(2)</sup>		±0.25		LSB
Gain error TC <sup>(2)</sup>	$AV_{DD} = +21V$ , $AV_{SS} = -11V$		±0.5		ppm FSR/°C
DC crosstalk <sup>(2)(3)</sup>	$AV_{DD} = +21V$ , $AV_{SS} = -11V$ , output unloaded			±0.1	LSB
<b>ANALOG OUTPUT (<math>V_{OUT-0}</math> to <math>V_{OUT-3}</math>)</b>					
Bipolar voltage output <sup>(4)</sup>	$AV_{DD} = +16.5V$ , $AV_{SS} = -16.5V$ , $V_{REF} = +7.5V$ , gain = 4	-15		+15	V
	$V_{REF} = +5V$ , gain = 4	-10		+10	V
Unipolar voltage output <sup>(4)</sup>	$AV_{DD} = +21V$ , $AV_{SS} = -11V$ , $V_{REF} = +5V$ , gain = 4	0		+20	V
Output voltage drift vs time	Operating for 500 hours at $+25^\circ\text{C}$		2		ppm of FSR
	Operating for 1000 hours at $+25^\circ\text{C}$		3		ppm of FSR
Output impedance <sup>(2)</sup>	±3mA load current		0.005		Ω
Short-circuit current <sup>(2)(5)</sup>			10		mA
Load current <sup>(4)</sup>	Output changes no more than ±1 LSB		±3		mA
Capacitive load stability <sup>(2)</sup>				700	pF
Power-supply rejection <sup>(2)(4)</sup>	$AV_{DD} = +5V$ to $+18V$ , $AV_{SS} = -5V$ to $-18V$ , $DV_{DD} = 5V \pm 10\%$ , $V_{REF} = 2V$		±0.1		LSB

(1) See the [User Calibration for Zero-Code Error and Gain Error](#) section for details.

(2) Specified by design and characterization.

(3) *DC crosstalk* is the dc change in the output of one channel as a result of a full-scale code change and subsequent output change on another channel. The DAC outputs are buffered by op amps that share common  $AV_{DD}$  and  $AV_{SS}$  power supplies. Multiple  $V_{DD}$  and  $V_{SS}$  terminals are provided to minimize dc crosstalk.

(4) The analog output must not be greater than  $(AV_{DD} - 1.0V)$  and must not be less than  $(AV_{SS} + 1.0V)$ .

(5) When the output current is greater than the specification, the current is clamped at the specified maximum value.

## ELECTRICAL CHARACTERISTICS (continued)

All specifications at  $T_A = T_{MIN}$  to  $T_{MAX}$ ,  $AV_{DD} = +11V$  to  $+18V$ ,  $AV_{SS} = -11V$  to  $-18V$ ,  $V_{REF} = REF-A = REF-B = +5V$ ,  $DV_{DD} = +5V$ ,  $IOV_{DD} = +1.8V$  to  $DV_{DD}$ ,  $AGND = DGND = REFGND-A = REFGND-B = SGND-x = 0V$ , and DAC gain = 4, unless otherwise noted.

PARAMETER	CONDITIONS	DAC8234			UNIT
		MIN	TYP	MAX	
<b>AC PERFORMANCE<sup>(6)</sup></b>					
Settling time	To 0.03% of FS, $C_L = 200pF$ , $R_L = 10k\Omega$ , output changes from $-10V$ to $+10V$ or $+10V$ to $-10V$		6		$\mu s$
	To 1 LSB, $C_L = 200pF$ , $R_L = 10k\Omega$ , output changes from $-10V$ to $+10V$ or $+10V$ to $-10V$		8		$\mu s$
	To 1 LSB, $C_L = 200pF$ , $R_L = 10k\Omega$ , code changes 512 LSBs		4		$\mu s$
Slew rate <sup>(7)</sup>	$C_L = 200pF$ , $R_L = 10k\Omega$		5		$V/\mu s$
Recovery time from power-down mode	Delay from clearing bit PD-x to when DAC returns to normal operation		50		$\mu s$
Digital-to-analog glitch <sup>(8)</sup>	1 LSB code change around midscale		8		$nV\cdot s$
Glitch impulse peak amplitude	1 LSB code change around midscale		15		mV
Channel-to-channel isolation <sup>(9)</sup>			-80		dB
DAC-to-DAC crosstalk <sup>(10)</sup>			2		$nV\cdot s$
Digital crosstalk <sup>(11)</sup>			2		$nV\cdot s$
Digital feedthrough <sup>(12)</sup>			2		$nV\cdot s$
Output noise	0.1Hz to 10Hz, $\pm 10V$ output range, gain = 4, midscale code		1		$\mu V_{RMS}$
	0.1Hz to 100kHz, $\pm 10V$ output range, gain = 4, midscale code		40		$\mu V_{RMS}$
1/f corner frequency			500		Hz
Output noise spectral density	$T_A = +25^\circ C$ , at 10kHz, $\pm 10V$ output range, gain = 4, midscale code		60		$nV/\sqrt{Hz}$
	$T_A = +25^\circ C$ , at 10kHz, 0V to $+10V$ output range, gain = 2, midscale code		45		$nV/\sqrt{Hz}$
<b>MONITOR PIN (<math>V_{MON}</math>)<sup>(6)</sup></b>					
Output impedance			2200		$\Omega$
High-impedance leakage current				100	nA
Continuous current limit				0.5	mA
<b>REFERENCE INPUT</b>					
Reference input voltage range		1		8	V
Reference input dc impedance		10	100		$M\Omega$
Reference input capacitance <sup>(6)</sup>			20		pF

(6) Specified by design and characterization.

(7) Slew rate is measured from 10% to 90% of the transition when the output changes from negative full-scale to positive full-scale.

(8) *Digital-to-analog glitch* is defined as the amount of energy injected into the analog output at the major code transition. It is specified as the area of the glitch in  $nV\cdot s$ . It is measured by toggling the DAC register data between 0000h and FFFCh in twos complement format.

(9) *Channel-to-channel isolation* refers to the ratio of the signal amplitude at the output of one DAC channel to the amplitude of the sinusoidal signal on the reference input of another DAC channel. It is expressed in dB and measured at midscale.

(10) *DAC-to-DAC crosstalk* is the glitch impulse that appears at the output of one DAC as a result of both the full-scale digital code and subsequent analog output change at another DAC. It is measured with LDAC tied low and expressed in  $nV\cdot s$ .

(11) *Digital crosstalk* is the glitch impulse transferred to the output of one converter as a result of a full-scale code change in the DAC input register of another converter. It is measured when the DAC output is not updated, and is expressed in  $nV\cdot s$ .

(12) *Digital feedthrough* is the glitch impulse injected to the output of a DAC as a result of a digital code change in the DAC input register of the same DAC. It is measured with the full-scale digital code change without updating the DAC output, and is expressed in  $nV\cdot s$ .

**ELECTRICAL CHARACTERISTICS (continued)**

All specifications at  $T_A = T_{MIN}$  to  $T_{MAX}$ ,  $AV_{DD} = +11V$  to  $+18V$ ,  $AV_{SS} = -11V$  to  $-18V$ ,  $V_{REF} = REF-A = REF-B = +5V$ ,  $DV_{DD} = +5V$ ,  $IOV_{DD} = +1.8V$  to  $DV_{DD}$ ,  $AGND = DGND = REFGND-A = REFGND-B = SGND-x = 0V$ , and DAC gain = 4, unless otherwise noted.

PARAMETER	CONDITIONS	DAC8234			UNIT
		MIN	TYP	MAX	
<b>DIGITAL INPUTS<sup>(13)</sup> (SDI, CS, SCLK, RST, UN/BIP-A, UN/BIP-B, LDAC, GPIO-x)</b>					
High-level input voltage, $V_{IH}$	$IOV_{DD} = 4.5V$ to $5.5V$	2.5		$IOV_{DD} + 0.3$	V
	$IOV_{DD} = 2.7V$ to $3.3V$	2.1		$IOV_{DD} + 0.3$	V
	$IOV_{DD} = +1.8V$	1.6		$IOV_{DD} + 0.3$	V
Low-level input voltage, $V_{IL}$	$IOV_{DD} = 4.5V$ to $5.5V$	-0.3		0.8	V
	$IOV_{DD} = 2.7V$ to $3.3V$	-0.3		0.6	V
	$IOV_{DD} = +1.8V$	-0.3		0.2	V
Input current				1	$\mu A$
Input capacitance			5		pF
<b>DIGITAL OUTPUTS<sup>(13)</sup> (SDO, GPIO-x)</b>					
SDO high-level output voltage, $V_{OH}$	$IOV_{DD} = 2.7V$ to $5.5V$ , sourcing 1mA	$IOV_{DD} - 0.4$			V
	$IOV_{DD} = +1.8V$ , sourcing 200 $\mu A$	1.6			V
SDO low-level output voltage, $V_{OL}$	$IOV_{DD} = 2.7V$ to $5.5V$ , sinking 1mA	0.4			V
	$IOV_{DD} = +1.8V$ , sinking 200 $\mu A$	0.2			V
SDO high-impedance leakage				1	$\mu A$
SDO high-impedance output capacitance			10		pF
GPIO low-level output voltage, $V_{OL}$	$IOV_{DD} = 2.7V$ to $5.5V$ , sinking 1mA	0		0.4	V
	$IOV_{DD} = +1.8V$ , sinking 1mA	0		0.4	V
GPIO open-drain high-level output leakage current	GPIO in Hi-Z and configured as output			1	$\mu A$
<b>POWER SUPPLY</b>					
$AV_{DD}$ <sup>(14)</sup>		+4.75		+24	V
$AV_{SS}$ <sup>(15)</sup>		-18		-4.75	V
$DV_{DD}$		+2.7		+5.5	V
$IOV_{DD}$		+1.7		$DV_{DD}$	V
$AI_{DD}$ (normal operation)	$\pm 10V$ output range, no loading current, $V_{OUT} = 0V$		2.7	3.4	mA/Channel
$AI_{DD}$ (power-down)				100	$\mu A$
$AI_{SS}$ (normal operation)	$\pm 10V$ output range, no loading current, $V_{OUT} = 0V$		3.3	4.0	mA/Channel
$AI_{SS}$ (power-down)				100	$\mu A$
$DI_{DD}$	Static current through the $DV_{DD}$ pin with $V_{IH} = IOV_{DD}$ and $V_{IL} = DGND$		25	50	$\mu A$
$IOI_{DD}$	$V_{IH} = IOV_{DD}$ , $V_{IL} = DGND$		$\pm 1$	$\pm 10$	$\mu A$
Power dissipation (normal operation)	$\pm 12V$ power, no loading current, $V_{OUT} = 0V$		290		mW
<b>TEMPERATURE RANGE</b>					
Specified performance			-40	+105	$^{\circ}C$

(13) Specified by design and characterization.

(14)  $AV_{DD}$  should not be greater than +24V or less than +4.75V. Also,  $AV_{DD}$  should not be less than  $(2 \times V_{REF} + 1V)$  for bipolar output mode and should not be less than  $(Gain \times V_{REF} + 1V)$  for unipolar output mode. In any case,  $(AV_{DD} - AV_{SS}) \leq +36V$ .

(15)  $AV_{SS}$  should not be greater than -4.75V or less than -18V. Also,  $AV_{SS}$  should not be greater than  $(-2 \times V_{REF} - 1V)$ . In any case,  $(AV_{DD} - AV_{SS}) \leq +36V$ .

[查询 DAC8234 资料库](#)

### FUNCTIONAL BLOCK DIAGRAM

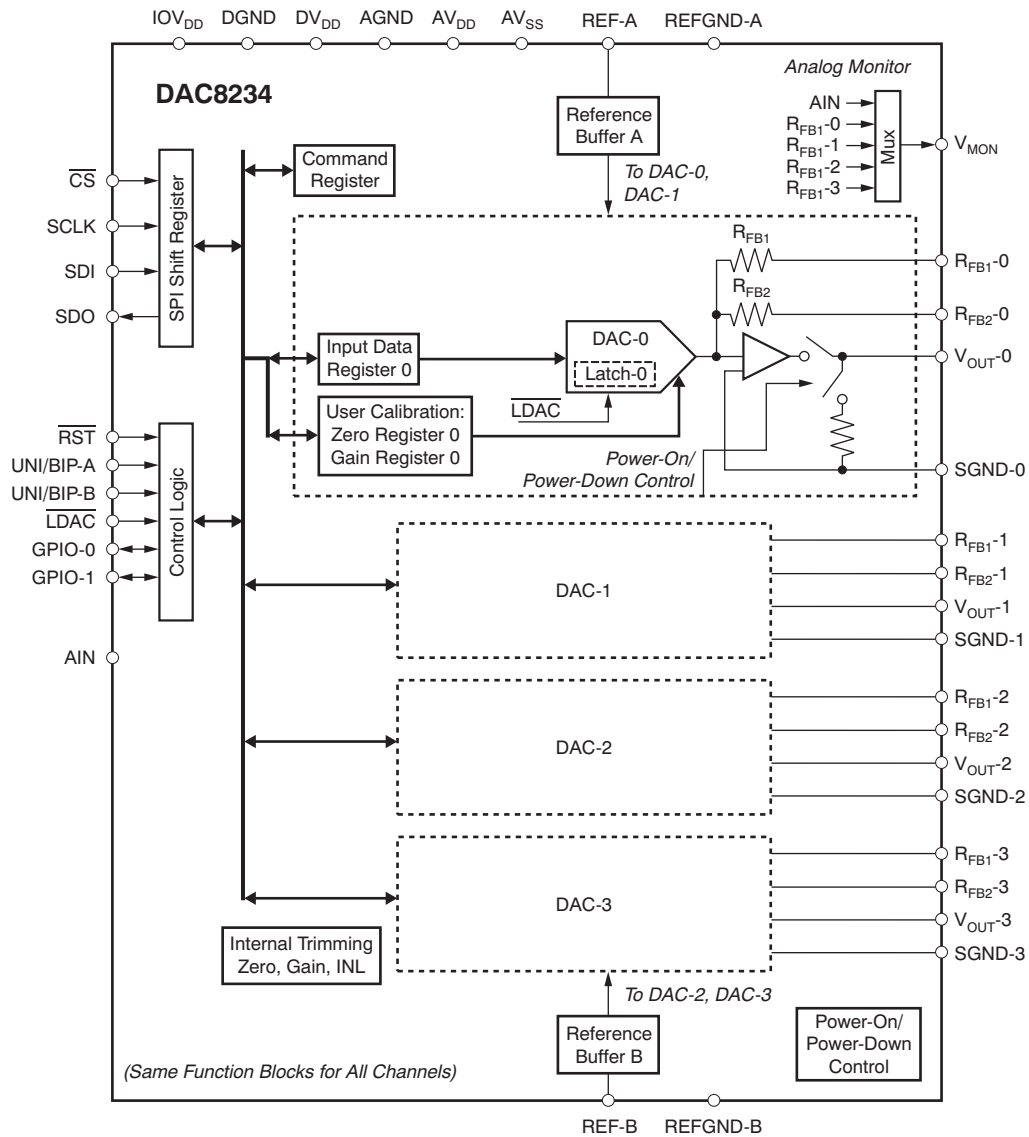

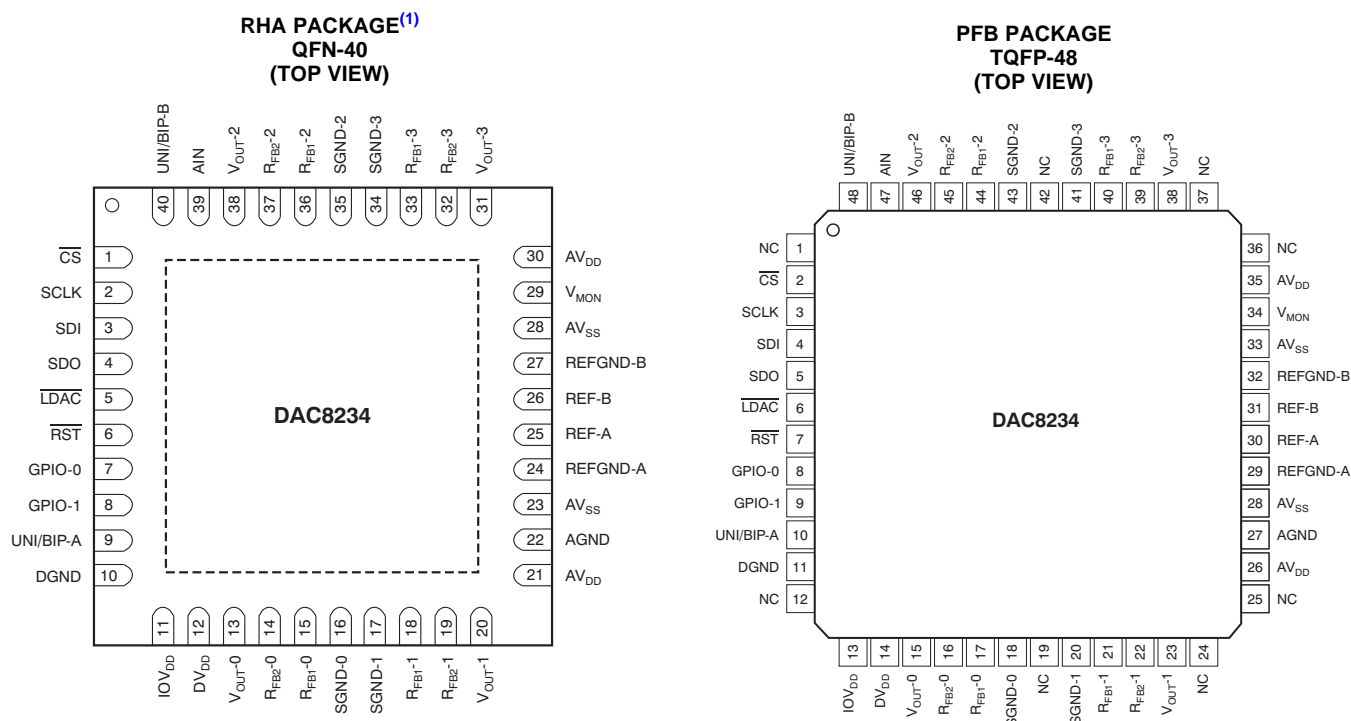
**PIN CONFIGURATIONS**

- (1) The thermal pad is internally connected to the substrate. This pad can be connected to AV<sub>SS</sub> or left floating.

**PIN DESCRIPTIONS**

PIN NAME	PIN NO.		I/O	DESCRIPTION
	QFN-40	TQFP-48		
$\overline{CS}$	1	2	I	SPI bus chip select input (active low). Data are not clocked into the SPI shift register unless $\overline{CS}$ is low. When $\overline{CS}$ is high, SDO is in a high-impedance state.
SCLK	2	3	I	SPI bus clock
SDI	3	4	I	SPI bus input data
SDO	4	5	O	SPI output data
$\overline{LDAC}$	5	6	I	Load DAC latch control input (active low). When $\overline{LDAC}$ is low, the DAC latch is transparent and the contents of the Input Data Register are transferred to it. The DAC output changes to the corresponding level simultaneously when the DAC latch is updated.
$\overline{RST}$	6	7	I	Reset input (active low). Logic low on this pin resets the input registers and DACs to the values defined by the UNI/BIP pins, and sets the Gain Register and Zero Register to default values.
GPIO-0	7	8	I/O	General-purpose digital input/output 0. This pin is a bidirectional, digital input/output, and has an open-drain output. A 10k $\Omega$ pull-up resistor to IOV <sub>DD</sub> is needed when this pin is used as an output. See the <a href="#">GPIO Pins</a> section for details.
GPIO-1	8	9	I/O	General-purpose digital input/output 1. This pin is a bidirectional, digital input/output, and has an open-drain output. A 10k $\Omega$ pull-up resistor to IOV <sub>DD</sub> is needed when this pin is used as an output. See the <a href="#">GPIO Pins</a> section for details.
UNI/BIP-A	9	10	I	Output mode selection of group A (DAC-0 and DAC-1). When UNI/BIP-A is tied to IOV <sub>DD</sub> , group A is in unipolar output mode; when tied to DGND, group A is in bipolar output mode. The input data written to the DAC are straight binary for unipolar output mode and twos complement for bipolar output mode.
DGND	10	11	I	Digital ground
IOV <sub>DD</sub>	11	13	I	Interface power
DV <sub>DD</sub>	12	14	I	Digital power
V <sub>OUT-0</sub>	13	15	O	DAC-0 output



### PIN DESCRIPTIONS (continued)

PIN NAME	PIN NO.		I/O	DESCRIPTION
	QFN-40	TQFP-48		
R <sub>FB2</sub> -0 <sup>(1)</sup>	14	16	O	DAC-0 R <sub>FB2</sub> feedback
R <sub>FB1</sub> -0 <sup>(1)</sup>	15	17	O	DAC-0 R <sub>FB1</sub> feedback
SGND-0	16	18	I	DAC-0 signal ground. Connected to REFGND-A.
SGND-1	17	20	I	DAC-1 signal ground. Connected to REFGND-A.
R <sub>FB1</sub> -1 <sup>(1)</sup>	18	21	O	DAC-1 R <sub>FB1</sub> feedback
R <sub>FB2</sub> -1 <sup>(1)</sup>	19	22	O	DAC-1 R <sub>FB2</sub> feedback
V <sub>OUT</sub> -1	20	23	O	DAC-1 output
AV <sub>DD</sub>	21, 30	26, 35	I	Positive analog power supply
AGND	22	27	I	Analog ground
AV <sub>SS</sub>	23, 28	28, 33	I	Negative analog power supply
REFGND-A	24	29	I	Reference REF-A ground. Connect to AGND.
REF-A	25	30	I	Group A (DAC-0, DAC-1) reference input
REF-B	26	31	I	Group B (DAC-2, DAC-3) reference input
REFGND-B	27	32	I	Reference REF-B ground. Connect to AGND.
V <sub>MON</sub>	29	34	O	Analog monitor output. This pin is either in Hi-Z status, or connected to one of the four DAC outputs or AIN, depending on the content of the Monitor Register.
V <sub>OUT</sub> -3	31	38	O	DAC-3 output
R <sub>FB2</sub> -3 <sup>(1)</sup>	32	39	O	DAC-3 R <sub>FB2</sub> feedback
R <sub>FB1</sub> -3 <sup>(1)</sup>	33	40	O	DAC-3 R <sub>FB1</sub> feedback
SGND-3	34	41	I	DAC-3 signal ground. Connected to REFGND-B.
SGND-2	35	43	I	DAC-2 signal ground. Connected to REFGND-B.
R <sub>FB1</sub> -2 <sup>(1)</sup>	36	44	O	DAC-2 R <sub>FB1</sub> feedback
R <sub>FB2</sub> -2 <sup>(1)</sup>	37	45	O	DAC-2 R <sub>FB2</sub> feedback
V <sub>OUT</sub> -2	38	46	O	DAC-2 output
AIN	39	47	I	Auxiliary analog input. Connected to the analog monitor mux.
UNI/BIP-B	40	48	I	Output mode selection of group B (DAC-2 and DAC-3). When UNI/BIP-A is tied to IOV <sub>DD</sub> , group B is in unipolar output mode; when tied to DGND, group B is in bipolar output mode. The input data written to the DAC are straight binary for unipolar output mode, and twos complement for bipolar output mode.
NC	—	1, 12, 19, 24, 25, 36, 37, 42		Not connected

- (1) To set the DAC-x gain = 2, connect R<sub>FB1</sub>-x and R<sub>FB2</sub>-x to V<sub>OUT</sub>-x, and set the corresponding GAIN bit in the Command Register to '0'. To set the DAC-x gain = 4, connect R<sub>FB1</sub>-x to V<sub>OUT</sub>-x, keep R<sub>FB2</sub>-x open, and set the corresponding GAIN bit in the Command Register to '1'. After power-on reset or user reset, the GAIN bits are set to '1' by default; for gain = 2, the gain bits must be cleared to '0'.

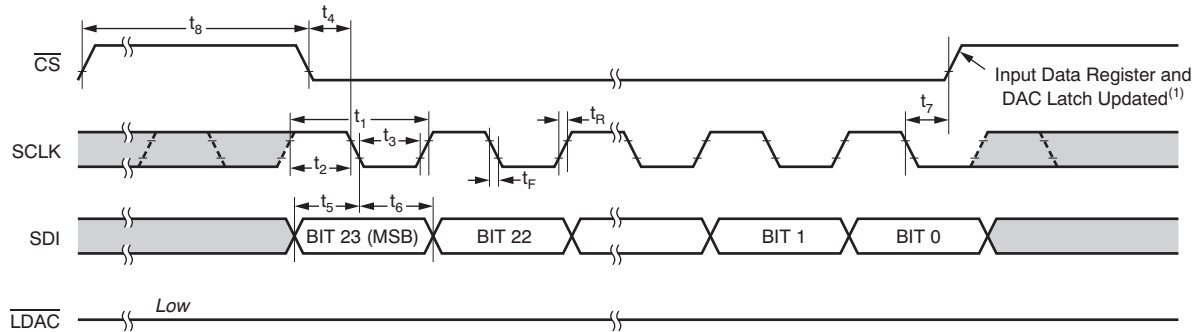
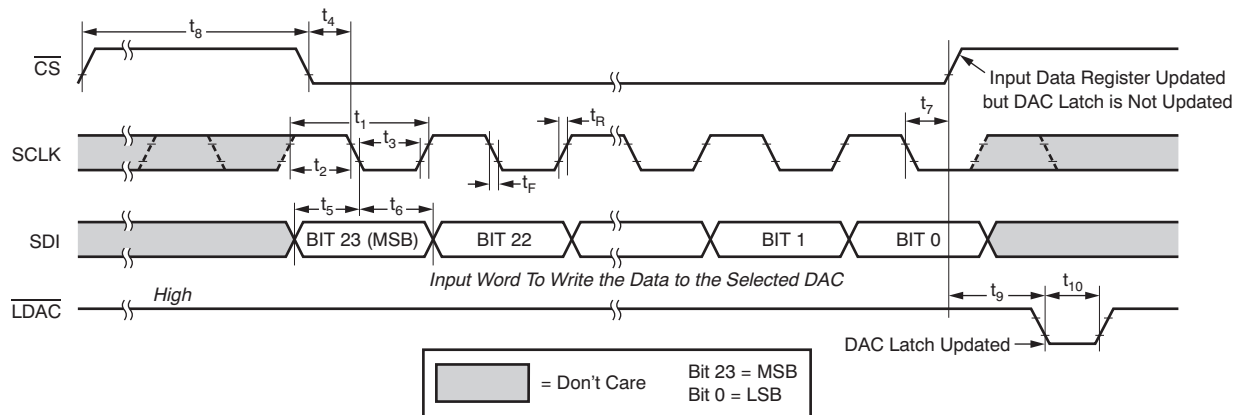

**TIMING DIAGRAMS**

 Case 1: Stand-alone mode,  $\overline{\text{LDAC}}$  tied low.

 Case 2: Stand-alone mode,  $\overline{\text{LDAC}}$  active high.

**Figure 1. SPI Timing for Stand-Alone Mode**
**TIMING CHARACTERISTICS For Figure 1<sup>(1)(2)(3)</sup>**

 At  $T_A = -40^\circ\text{C}$  to  $+105^\circ\text{C}$ , unless otherwise noted.

PARAMETER	$2.7\text{V} \leq \text{DV}_{\text{DD}} \leq 5.5\text{V}$ , $\text{IOV}_{\text{DD}} = 1.8\text{V}$		$2.7\text{V} \leq \text{DV}_{\text{DD}} \leq 3.6\text{V}$ , $2.7\text{V} \leq \text{IOV}_{\text{DD}} \leq \text{DV}_{\text{DD}}$		$3.6\text{V} < \text{DV}_{\text{DD}} \leq 5.5\text{V}$ , $2.7\text{V} \leq \text{IOV}_{\text{DD}} \leq \text{DV}_{\text{DD}}$		UNIT
	MIN	MAX	MIN	MAX	MIN	MAX	
$f_{\text{SCLK}}$ Clock frequency		30		40		50	MHz
$t_1$ SCLK cycle time	33		25		20		ns
$t_2$ SCLK high time	16		12		10		ns
$t_3$ SCLK low time	16		12		10		ns
$t_4$ $\overline{\text{CS}}$ falling edge to SCLK falling edge <sup>(4)</sup>	11		9		7		ns
$t_5$ Input data setup time	5		5		5		ns
$t_6$ Input data hold time	5		5		5		ns
$t_7$ SCLK falling edge to $\overline{\text{CS}}$ rising edge	15		12		10		ns
$t_8$ $\overline{\text{CS}}$ high time	60		50		30		ns
$t_9$ $\overline{\text{CS}}$ rising edge to $\overline{\text{LDAC}}$ falling edge	30		25		20		ns
$t_{10}$ $\overline{\text{LDAC}}$ pulse width	25		20		15		ns
$\overline{\text{RST}}$ pulse width	25		20		15		ns

(1) Specified by design and characterization.

(2) Sample tested during the initial release and after any redesign or process changes that may affect these parameters.

 (3) All input signals are specified with  $t_R = t_F = 2\text{ns}$  (10% to 90% of  $\text{IOV}_{\text{DD}}$ ) and timed from a voltage level of  $\text{IOV}_{\text{DD}}/2$ .

 (4) The first SCLK edge after  $\overline{\text{CS}}$  goes low must be a falling edge.

[查询 DAC8234R 应用](#)

Case 3: Daisy-Chain mode,  $\overline{\text{LDAC}}$  tied low.

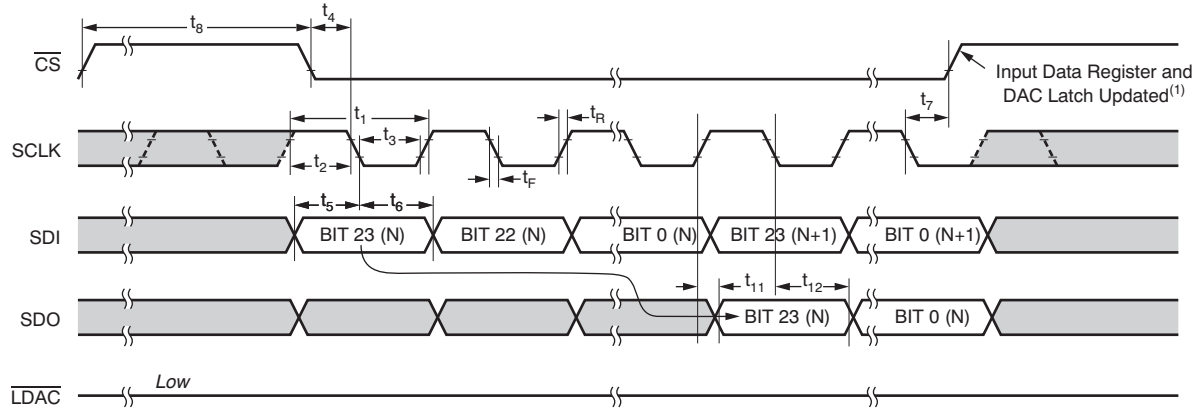

Case 4: Daisy-Chain mode,  $\overline{\text{LDAC}}$  active.

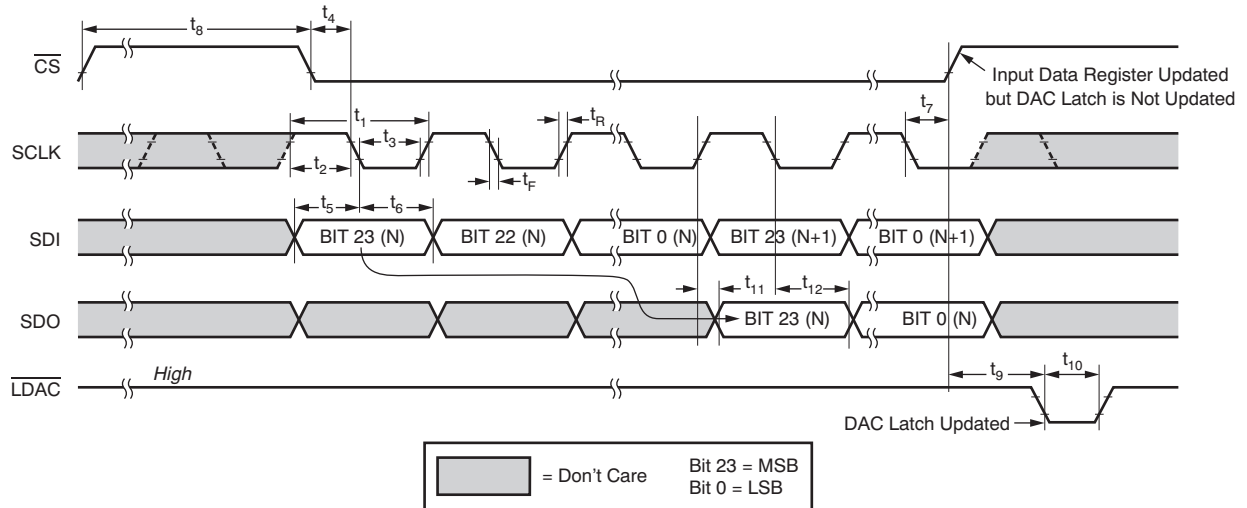

Figure 2. SPI Timing for Daisy-Chain Mode

Case 5: Readback for Stand-alone mode.

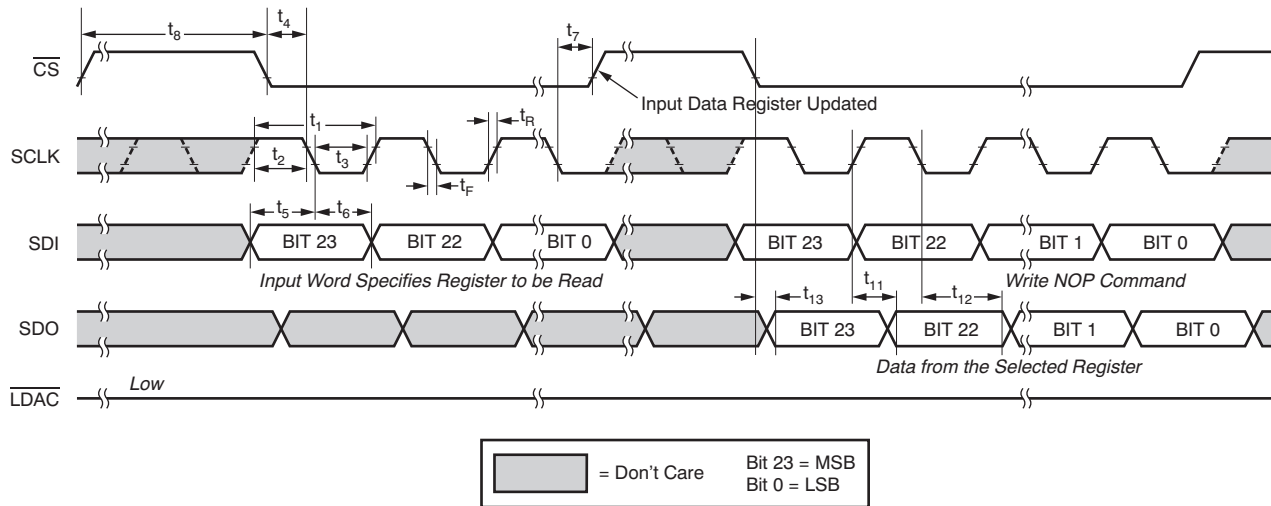

Figure 3. SPI Timing for Readback Operation in Stand-Alone Mode

**TIMING CHARACTERISTICS For Figure 2 to Figure 3<sup>(1)(2)(3)</sup>**

At  $T_A = -40^{\circ}\text{C}$  to  $+105^{\circ}\text{C}$ , unless otherwise noted.

PARAMETER	$2.7\text{V} \leq \text{DV}_{\text{DD}} \leq 5.5\text{V}, \text{IOV}_{\text{DD}} = 1.8\text{V}$		$2.7\text{V} \leq \text{DV}_{\text{DD}} \leq 3.6\text{V}, 2.7\text{V} \leq \text{IOV}_{\text{DD}} \leq \text{DV}_{\text{DD}}$		$3.6\text{V} < \text{DV}_{\text{DD}} \leq 5.5\text{V}, 2.7\text{V} \leq \text{IOV}_{\text{DD}} \leq \text{DV}_{\text{DD}}$		UNIT
	MIN	MAX	MIN	MAX	MIN	MAX	
$f_{\text{SCLK}}$ Clock frequency	15		20		25		MHz
$t_1$ SCLK cycle time	66		50		40		ns
$t_2$ SCLK high time	33		25		20		ns
$t_3$ SCLK low time	33		25		20		ns
$t_4$ $\overline{\text{CS}}$ falling edge to SCLK falling edge <sup>(4)</sup>	25		22		17		ns
$t_5$ Input data setup time	5		5		5		ns
$t_6$ Input data hold time	5		5		5		ns
$t_7$ SCLK falling edge to $\overline{\text{CS}}$ rising edge	15		12		10		ns
$t_8$ $\overline{\text{CS}}$ high time	60		50		30		ns
$t_9$ $\overline{\text{CS}}$ rising edge to $\overline{\text{LDAC}}$ falling edge	30		25		20		ns
$t_{10}$ $\overline{\text{LDAC}}$ pulse width	25		20		15		ns
$t_{11}$ SDO data valid from SCLK rising edge		25		20		15	ns
$t_{12}$ SDO data hold time from SCLK falling edge	30		25		20		ns
$t_{13}$ SDO data valid from $\overline{\text{CS}}$ falling edge		20		17		12	ns
$\overline{\text{RST}}$ pulse width	25		20		15		ns

- (1) Specified by design and characterization.
- (2) Sample tested during the initial release and after any redesign or process changes that may affect these parameters.
- (3) All input signals are specified with  $t_R = t_F = 2\text{ns}$  (10% to 90% of  $\text{IOV}_{\text{DD}}$ ) and timed from a voltage level of  $\text{IOV}_{\text{DD}}/2$ .
- (4) The first SCLK edge after  $\overline{\text{CS}}$  goes low must be a falling edge.

TYPICAL CHARACTERISTICS

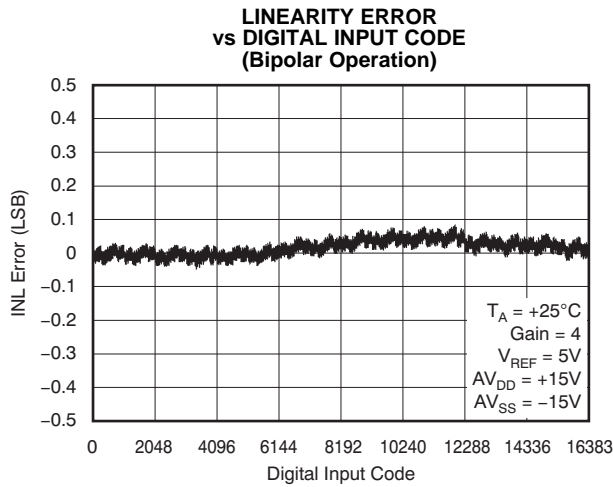

Figure 4.

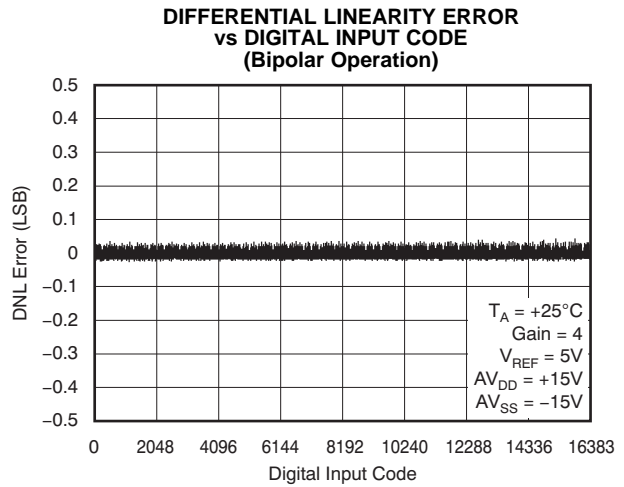

Figure 5.

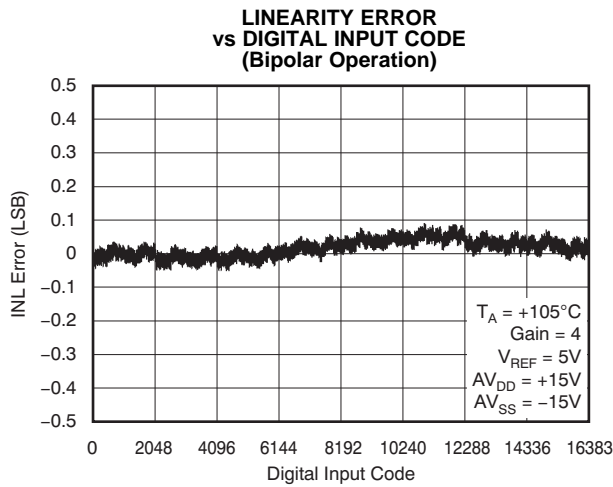

Figure 6.

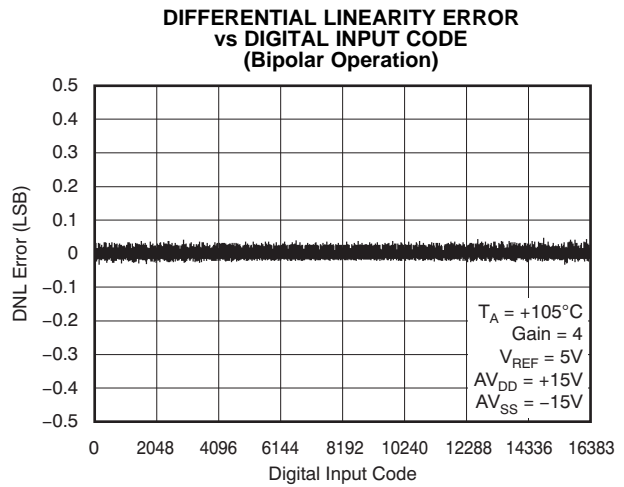

Figure 7.

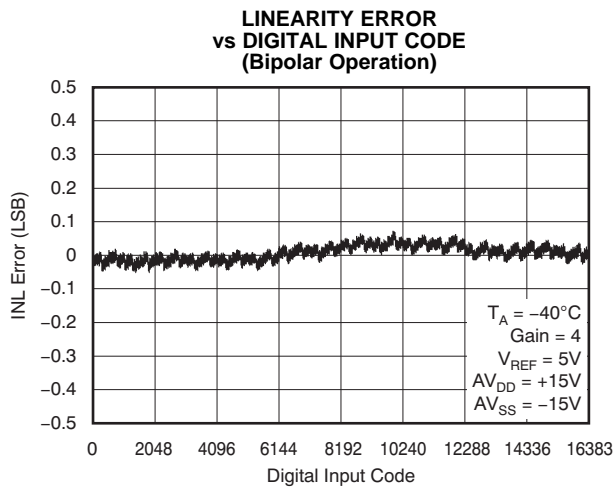

Figure 8.

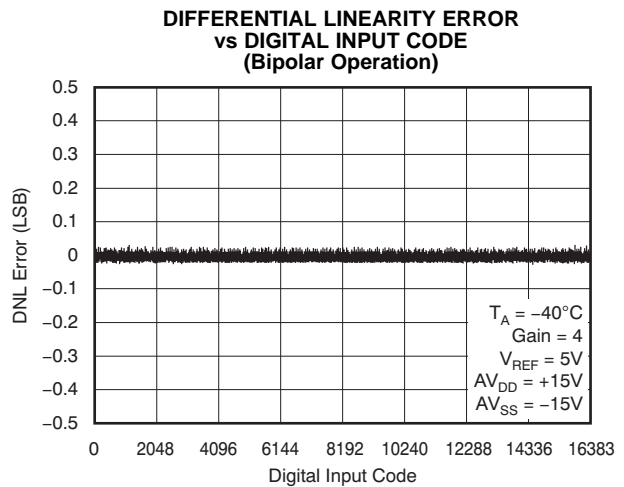
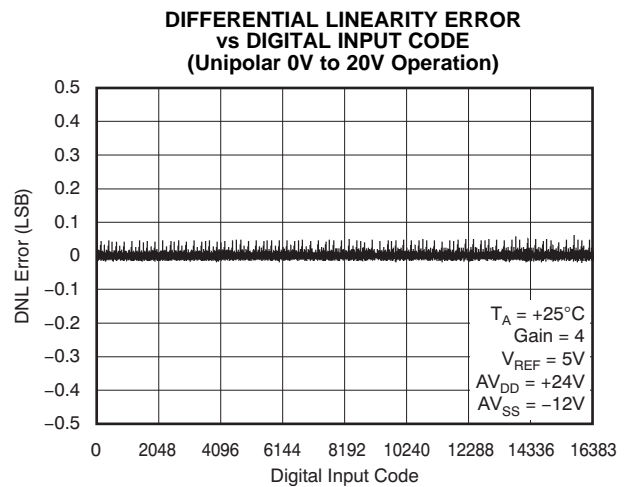
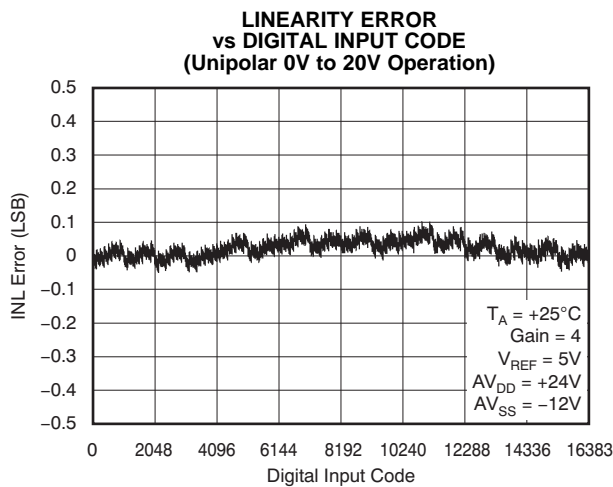
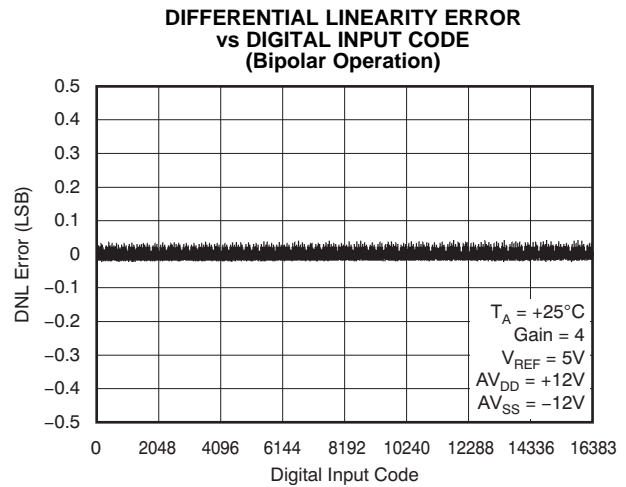
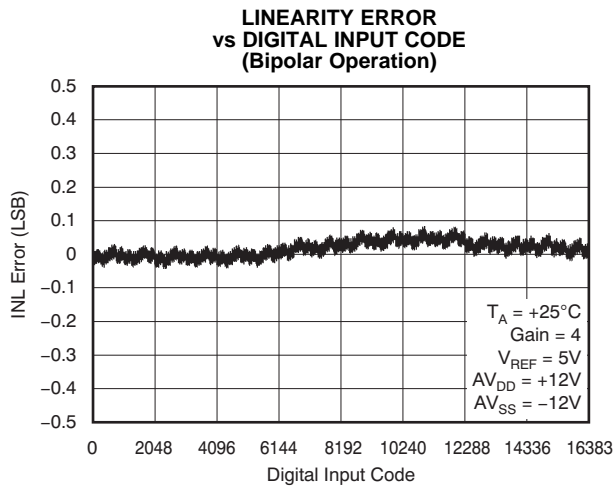
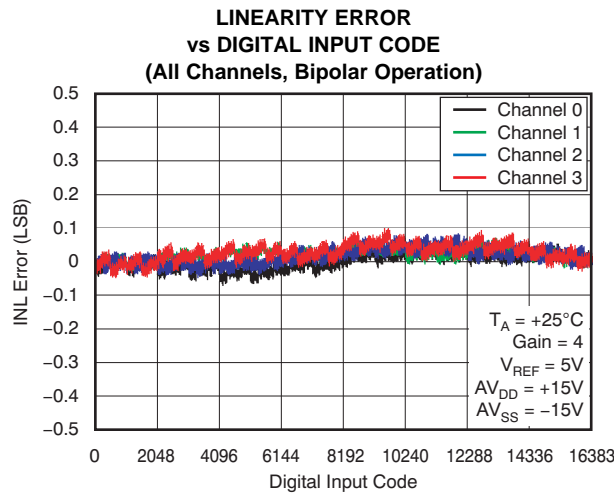

Figure 9.

TYPICAL CHARACTERISTICS (continued)



TYPICAL CHARACTERISTICS (continued)

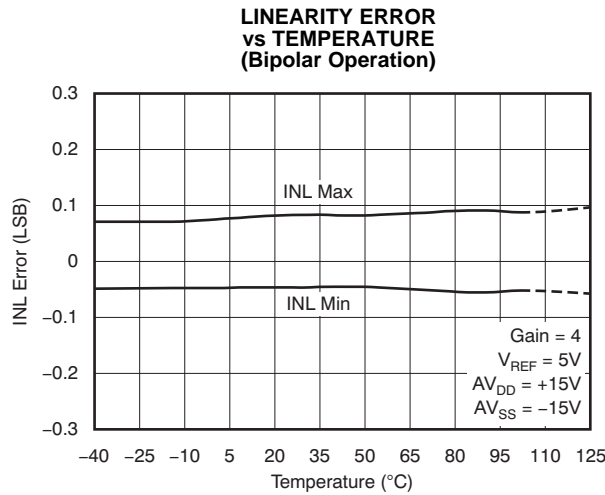

Figure 15.

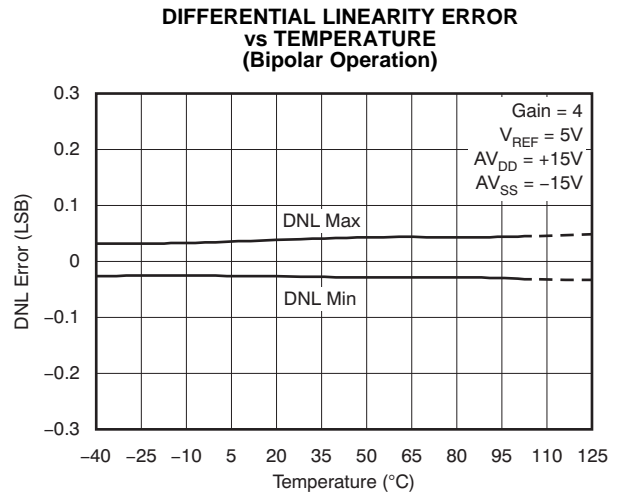

Figure 16.

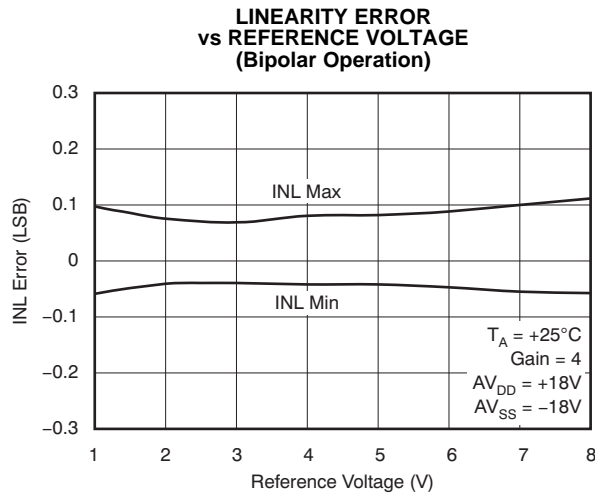

Figure 17.

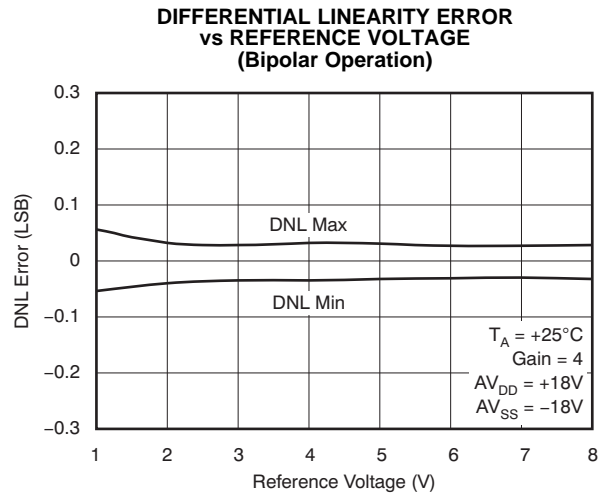

Figure 18.

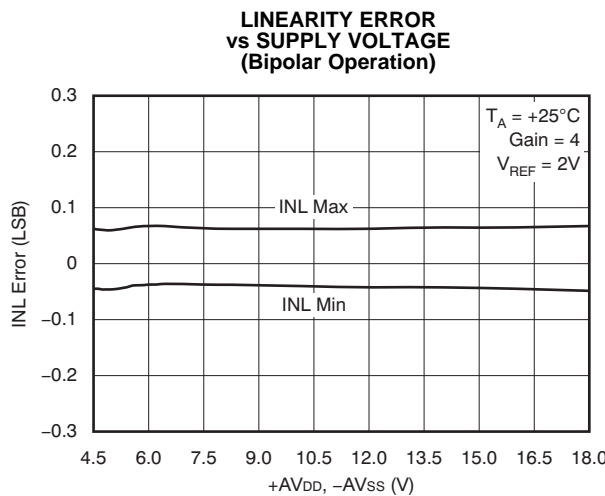

Figure 19.

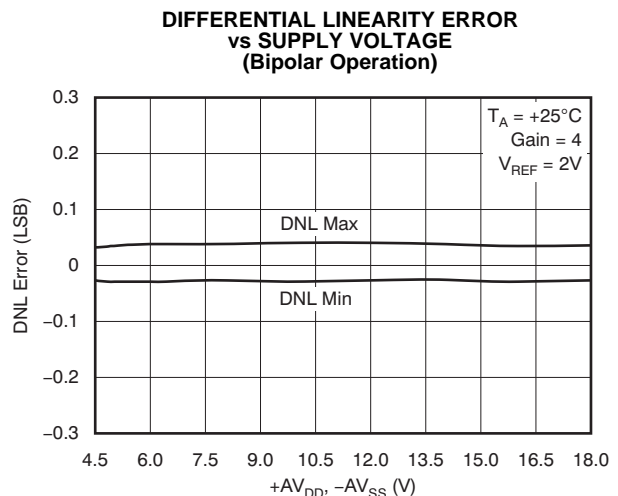

Figure 20.

TYPICAL CHARACTERISTICS (continued)

**BIPOLAR GAIN ERROR vs REFERENCE VOLTAGE**  
(10 Units, 40 Channels Total)

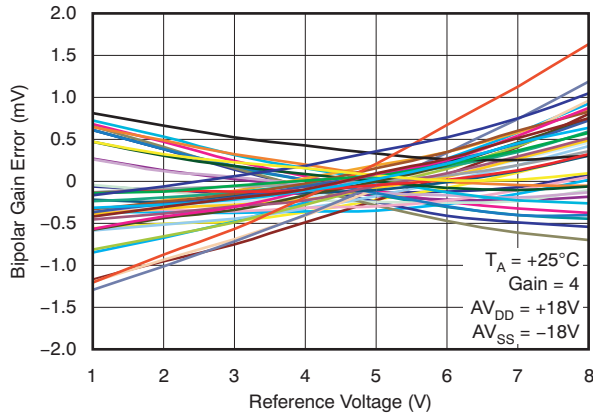

Figure 21.

**BIPOLAR ZERO ERROR vs REFERENCE VOLTAGE**  
(10 Units, 40 Channels Total)

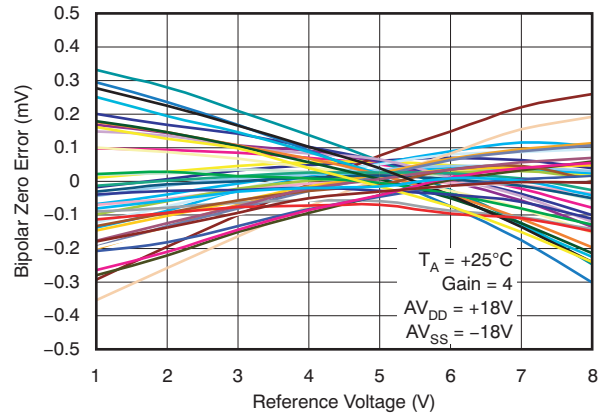

Figure 22.

**BIPOLAR GAIN ERROR vs TEMPERATURE**  
(10 Units, 40 Channels Total)

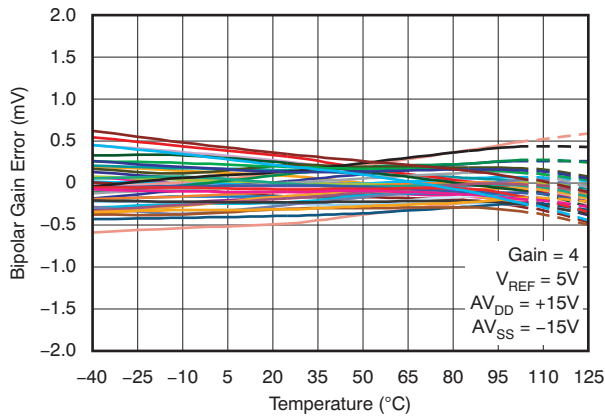

Figure 23.

**BIPOLAR ZERO ERROR vs TEMPERATURE**  
(10 Units, 40 Channels Total)

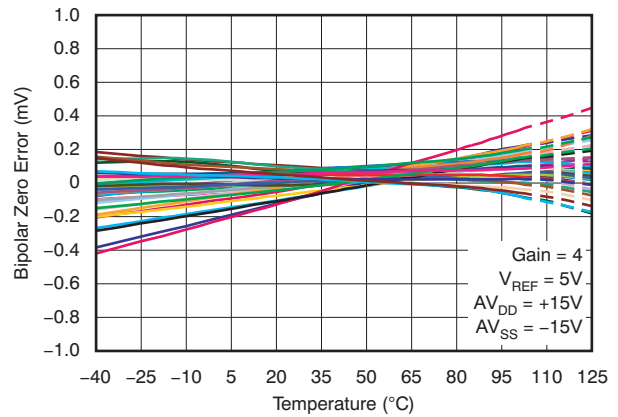

Figure 24.

**UNIPOLAR ZERO ERROR vs REFERENCE VOLTAGE**  
(10 Units, 40 Channels Total)

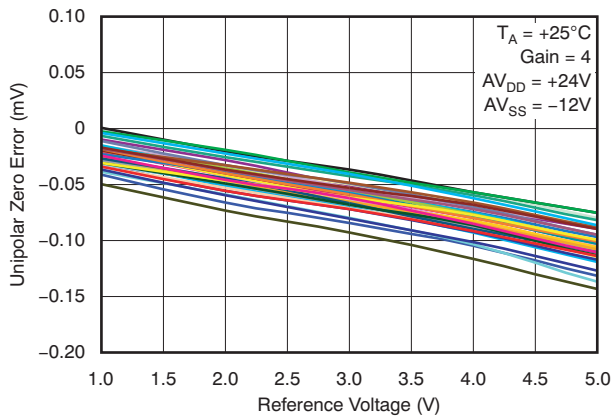

Figure 25.

**UNIPOLAR ZERO ERROR vs TEMPERATURE**  
(10 Units, 40 Channels Total)

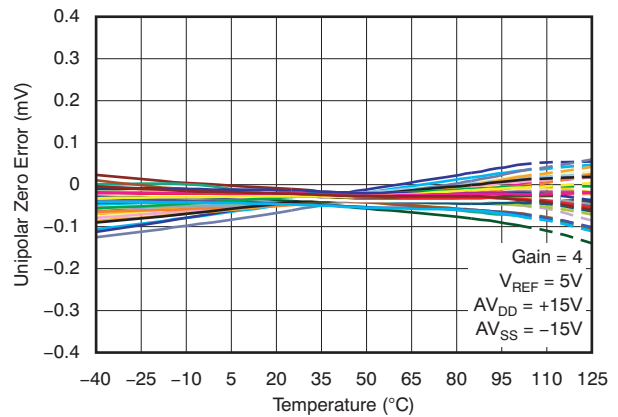

Figure 26.



TYPICAL CHARACTERISTICS (continued)

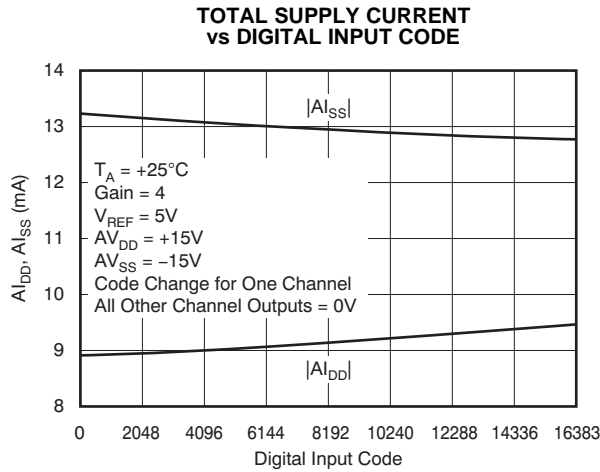

Figure 27.

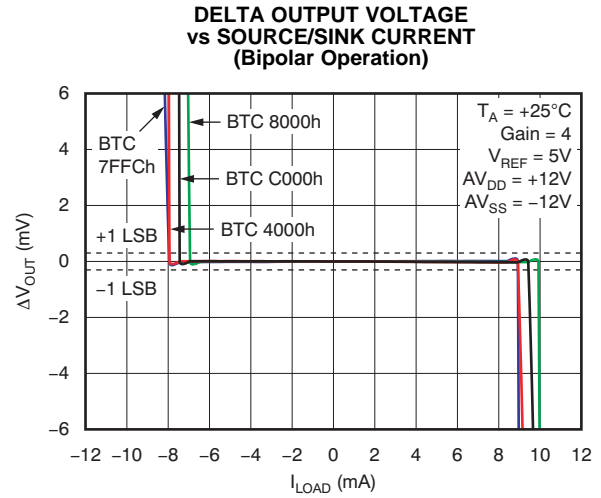

Figure 28.

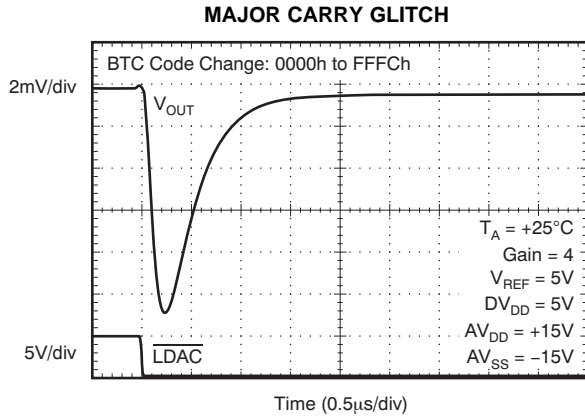

Figure 29.

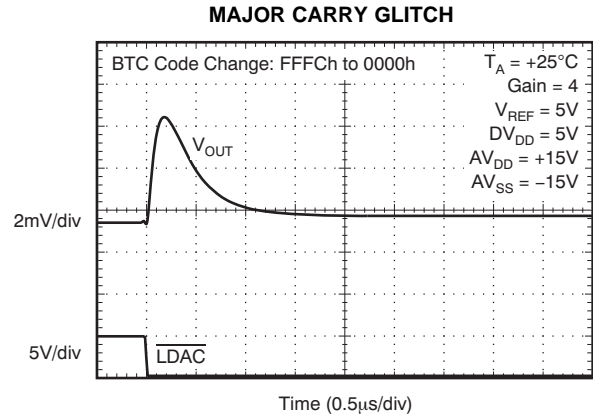

Figure 30.

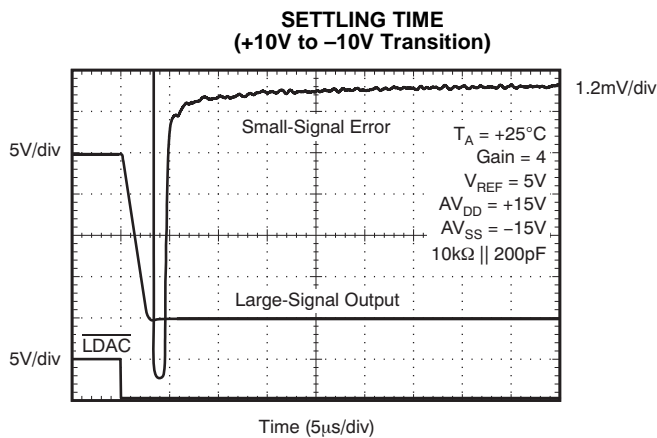

Figure 31.

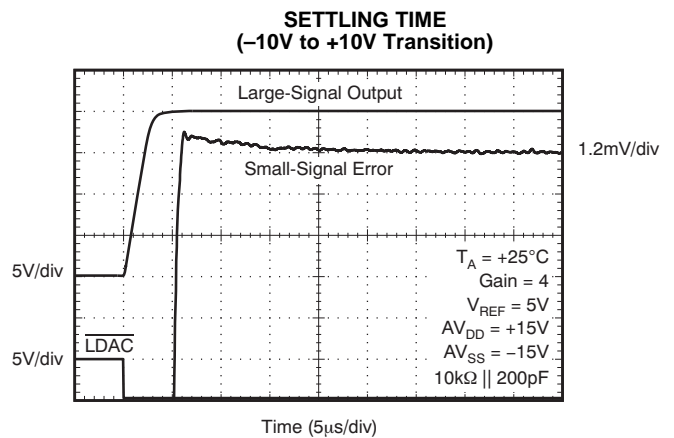

Figure 32.

TYPICAL CHARACTERISTICS (continued)

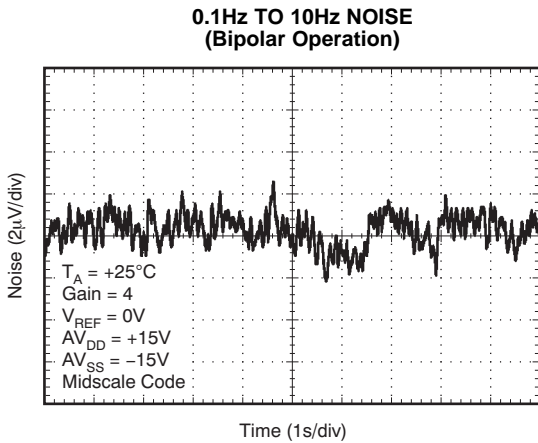

Figure 33.

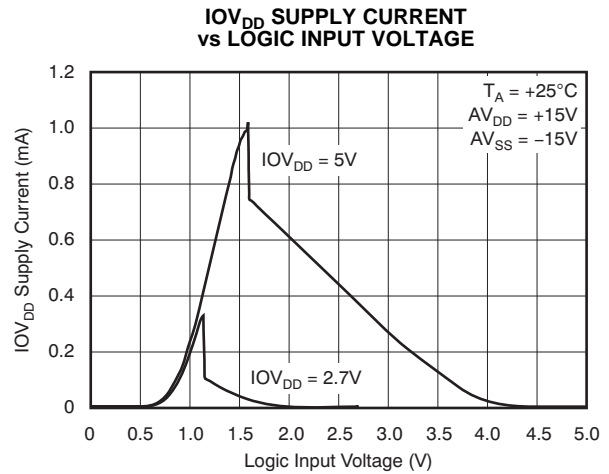

Figure 34.

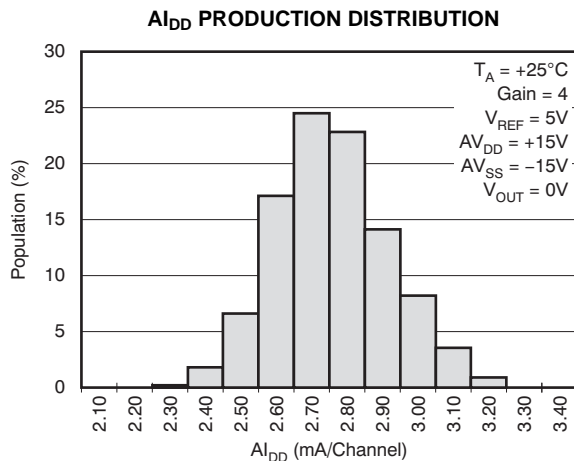

Figure 35.

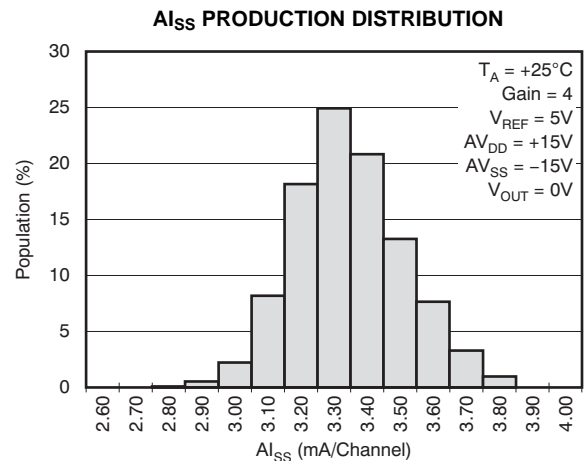

Figure 36.

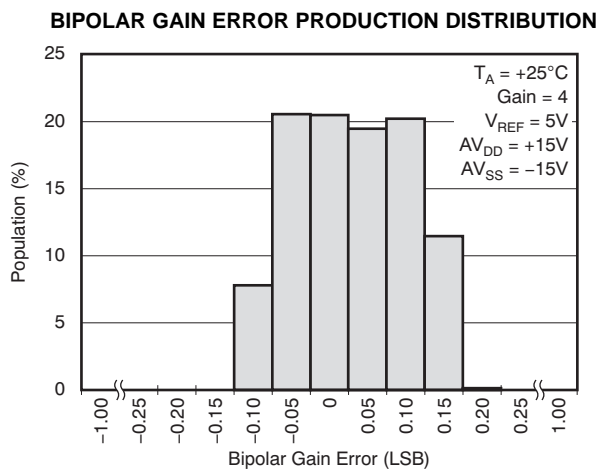

Figure 37.

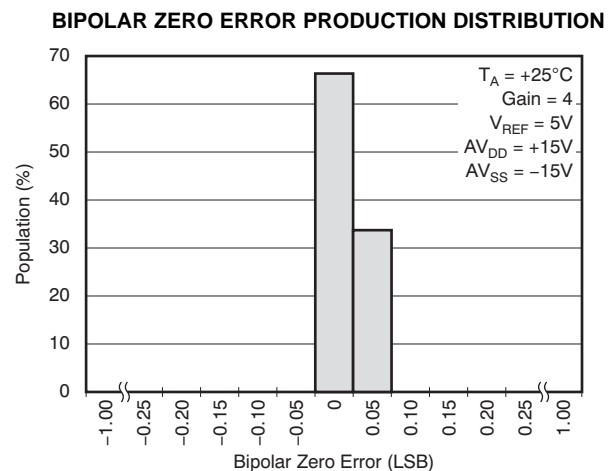

Figure 38.

TYPICAL CHARACTERISTICS (continued)

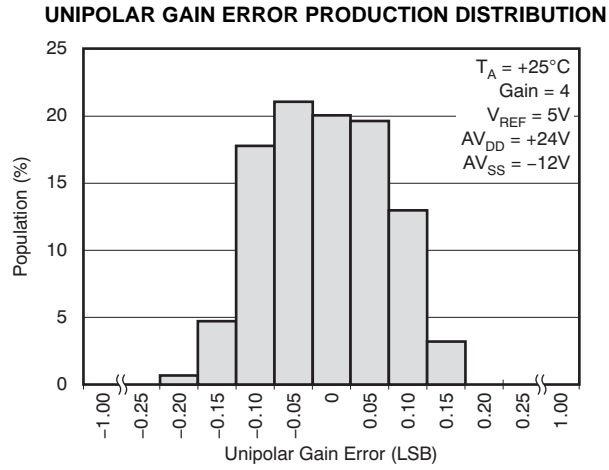

Figure 39.

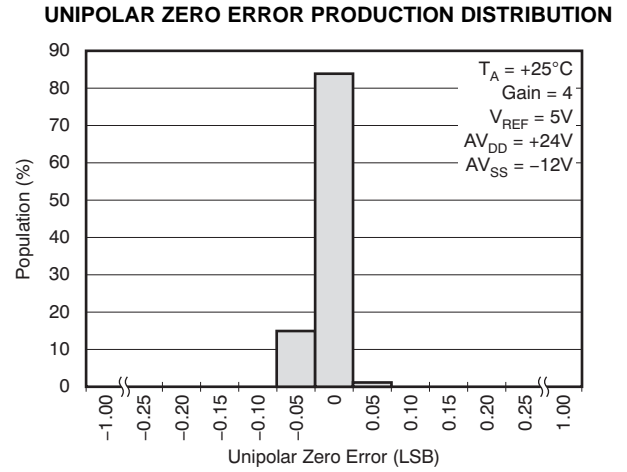
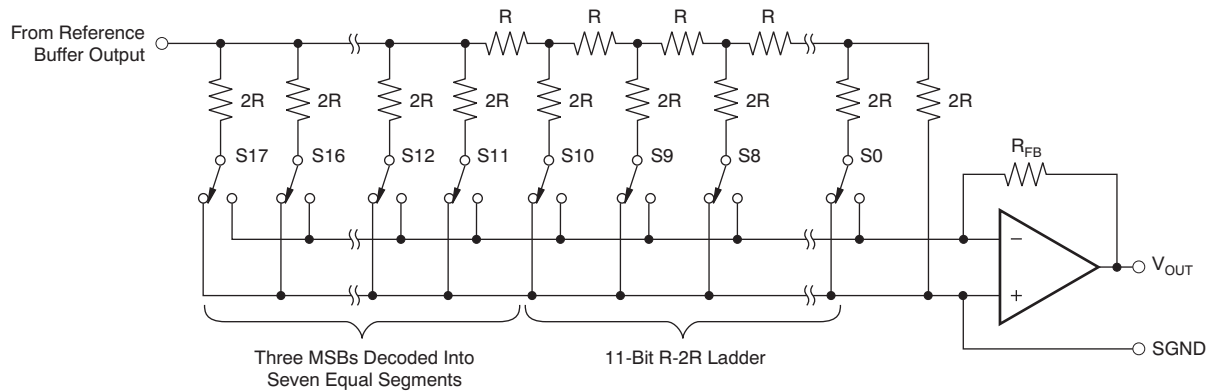

Figure 40.

## THEORY OF OPERATION

### DAC ARCHITECTURE

The DAC8234 is a highly-integrated, quad-channel, 14-bit, voltage-output DAC with internal reference buffers and output buffers. Each channel consists of an R-2R ladder configuration with the three MSBs segmented, followed by an operational amplifier, as shown in Figure 41. The DAC8234 has a high-impedance, buffered reference input; the output of the reference buffers drives the R-2R ladders. The output buffer is designed to allow user-configurable adjustments, giving the DAC8234 four different output voltage range settings. With the production trim process, this device has excellent dc accuracy and ac performance.



**Figure 41. DAC8234 Architecture**

### CHANNEL GROUPS

The four DAC channels are arranged into two groups (A and B) with two channels per group. Group A consists of DAC-0 and DAC-1, and Group B consists of DAC-2 and DAC-3. The two DAC channels of Group A derive their reference voltage from REF-A, and those of Group B from REF-B.

### USER-CALIBRATION FOR ZERO ERROR AND GAIN ERROR

The DAC8234 implements a user-calibration function that allows for trimming the system gain and zero errors. Each DAC channel has a Gain Register and Zero Register and the DAC output is calibrated according to the value of the corresponding registers. The range of gain adjustment is typically  $\pm 0.195\%$  of full-scale with 0.25 LSB per step. The zero code adjustment is typically  $\pm 0.0488\%$  of full-scale with 0.03125 LSB per step. The input data format of the Gain and Zero registers is twos complement. Refer to Table 9 and Table 10 for more details.

If the system-level calibration is not needed, these registers should be left at the respective default values (0000h) at power-on.

## TRANSFER FUNCTION FOR THE ANALOG OUTPUTS ( $V_{OUT-0}$ to $V_{OUT-3}$ )

For bipolar output:

$$V_{OUT} = \text{Gain} \times V_{REF} \times \left( \frac{\text{INPUT\_CODE}}{16384} + \frac{\text{ZERO\_CODE}}{32 \times 16384} \right) \times \left( 1 + \frac{\text{GAIN\_CODE}}{8 \times 16384} \right) \quad (1)$$

For unipolar output:

$$V_{OUT} = \text{Gain} \times V_{REF} \times \left( \frac{\text{INPUT\_CODE}}{16384} + \frac{\text{ZERO\_CODE}}{32 \times 16384} \right) \times \left( 1 + \frac{\text{GAIN\_CODE}}{4 \times 16384} \right) \quad (2)$$

Where:

GAIN is the DAC gain, which can be set to x2 or x4 and is determined by the connection of pins  $R_{FB1-x}$  and  $R_{FB2-x}$  to  $V_{OUT-x}$ , and the GAIN bit in the Command Register.

INPUT\_CODE is the decimal equivalent value of the code written into the DAC input register.

ZERO\_CODE is the decimal equivalent value of the code written into the Zero Register.

GAIN\_CODE is the decimal equivalent value of the code written into the Gain Register.

Note that the output voltage must not be greater than  $(AV_{DD} - 1.0V)$  or less than  $(AV_{SS} + 1.0V)$ ; otherwise, the output may be saturated.

### Input Data Format

For bipolar output operation, INPUT\_CODE is always twos complement, and can accept values between -8192 to 8191.

For unipolar output operation, INPUT\_CODE is always straight binary, and can accept values between 0 to 16383.

GAIN\_CODE is always in twos complement format, and can accept values between -128 and +127.

ZERO\_CODE is always in twos complement format and can accept values between -256 and +255.

The data written to the Command and Monitor registers are written as specified in the definitions. For read operations, the read-back data format is the same as the format used to write to the device. Refer to the [Internal Registers](#) section for more details.

### OUTPUT RANGE

Each channel of the DAC8234 implements an output amplifier that provides a unipolar output or a bipolar output with a gain of 2 or 4. The output span equals the gain times the reference voltage. For a 5V reference, the output range can be configured as  $\pm 10V$ ,  $\pm 5V$ , 0V to 20V, or 0V to 10V. The status of the UNI/BIP pin determines the output mode (unipolar or bipolar) of each group. When the UNI/BIP-A pin is high, the outputs of Group A (DAC-0 and DAC-1) are unipolar; when the pin is low, the outputs of Group A are bipolar. Similarly, the UNI/BIP-B pin defines the output mode of Group B (DAC-2 and DAC-3).

Each individual DAC can be configured with a gain of 4 or a gain of 2. To set the gain = 4, connect  $R_{FB1-x}$  to  $V_{OUT-x}$  with  $R_{FB2-x}$  left open, and set the gain bit for that channel to '1' in the Command Register. To set the gain = 2, connect both  $R_{FB1-x}$  and  $R_{FB2-x}$  to  $V_{OUT-x}$ , and set the gain bit for that channel to '0'. The gain bits in the Command Register are set to '1' by default at power-on or reset, and must be cleared to '0' for gain = 2.

Note that the power supplies must meet the following requirements:

- $AV_{DD}$  must not be greater than 24V or less than 4.75V, and  $AV_{SS}$  must not be greater than -4.75V or less than -18V. In any case,  $(AV_{DD} - AV_{SS}) \leq 36V$ .
- For bipolar mode:  $AV_{DD} \geq 2 \times V_{REF} + 1V$ , and  $AV_{SS} \leq -2 \times V_{REF} - 1V$ .
- For unipolar mode:  $AV_{DD} \geq \text{Gain} \times V_{REF} + 1V$ , and  $AV_{SS} \leq -2 \times V_{REF} - 1V$ .

For example, for a 5V reference in bipolar operation, the minimum supplies must be at least  $\pm 11V$ , regardless of whether the output range is  $\pm 5V$  or  $\pm 10V$ . For unipolar operation with the same reference, the supplies must be at least  $\pm 11V$  for a 0V to 10V operation, and  $+21V/-11V$  for a 0V to +20V operation.

## UPDATING THE DAC OUTPUTS

The DAC8234 has a double-buffered interface that consists of two register banks for every channel: the input register and the DAC latch. The digital code is transferred from the SPI shift register to the addressed channel input register upon completion of a valid write sequence. The DAC latch contains the digital code used by the resistor R-2R ladder. The contents of the DAC latch define the output from the DAC. The DAC outputs can be updated individually or simultaneously. The DAC8234 updates the DAC latch only if it has been accessed since the last time the  $\overline{\text{LDAC}}$  pin was brought low or the LD bit in the Command Register was set to '1', thereby eliminating any unnecessary glitch. The DAC channels that were not accessed are not reloaded, and the output values remain unchanged.

### Individual DAC Channel Update

In this mode, the  $\overline{\text{LDAC}}$  pin is held low while the  $\overline{\text{CS}}$  pin is low and the data are clocked into the SPI shift register. At the end of the data transfer into the shift register, the  $\overline{\text{CS}}$  pin is brought high. This action updates both the addressed input data register and the corresponding DAC latch register. The DAC latch register controls the R-2R switches; thus, an update on the DAC latch register updates the corresponding DAC channel analog output.

### Simultaneous Update of Multiple DAC Channels

In this mode, the  $\overline{\text{LDAC}}$  pin is held high while the  $\overline{\text{CS}}$  pin is low and data are clocked into the SPI shift register. At the end of the data transfer into the shift register, the  $\overline{\text{CS}}$  pin is brought high. This action updates only the addressed input data register; it does not update the DAC latch register or change the output. The DAC latch and the analog output are updated only when the  $\overline{\text{LDAC}}$  pin goes low, or when the LD bit in the Command Register is set to '1' at anytime after the input data register is written.

## HARDWARE RESET

When the  $\overline{\text{RST}}$  pin is low, the device is in hardware reset. All the analog outputs ( $V_{\text{OUT-0}}$  to  $V_{\text{OUT-3}}$ ), the input registers, and the DAC latches are set to the reset values shown in [Table 1](#). All registers are loaded with default values. Communication is disabled, and the signals on the SDI,  $\overline{\text{CS}}$ , and SCLK pins are ignored. On the rising edge of the  $\overline{\text{RST}}$  pin, the analog outputs ( $V_{\text{OUT-0}}$  to  $V_{\text{OUT-3}}$ ) maintain the reset value (0V) until a new value is programmed. After the  $\overline{\text{RST}}$  pin goes high, the device returns to normal operation. Note that the default values of the gain bits in the Command Register are '1' after a reset. For gain = 2, the gain bits must be cleared to '0'.

**Table 1. Reset Values**

UNI/BIP PIN	OUTPUT MODE	INPUT FORMAT	VALUE OF INPUT REGISTER AND DAC LATCH	$V_{\text{OUT}}$
DGND	Bipolar	Twos Complement	0000h	0V
IOV <sub>DD</sub>	Unipolar	Straight Binary	0000h	0V

Setting the RST bit in the Command Register to '1' performs a software reset, which is functionally the same as a hardware reset. After reset completes, the RST bit returns to '0' automatically.

## POWER-ON RESET

On power-on, the input data registers and DAC latches are loaded with the value defined by the UNI/BIP pins (see [Table 1](#)). All other registers are loaded with default values. After power-on, the outputs of the  $V_{\text{OUT}}$  pins are set to 0V.

## ANALOG OUTPUT MONITOR PIN ( $V_{MON}$ )

The  $V_{MON}$  pin is the analog output monitor. The analog output monitor function consists of an analog multiplexer addressed via the serial interface, allowing one of the four channel outputs or the AIN input to be routed to this pin for monitoring. The monitor function is controlled by the Monitor Register, which allows the monitored output to be enabled or disabled. When all multiplexer channels are disabled, the monitor output is high impedance; therefore, several monitor outputs can be connected in parallel with only one enabled at a time. Table 5 shows the settings relevant to the monitor function.

Note that the multiplexer is implemented as a series of analog switches. Care should be taken to ensure the maximum current from the  $V_{MON}$  pin must not be greater than the given specification because such a condition could conceivably cause a large amount of current to flow from the input of the multiplexer (that is, from  $V_{OUT-x}$  or AIN) to the output of the multiplexer ( $V_{MON}$ ). Also, the  $V_{MON}$  pin output impedance is approximately 2.2k $\Omega$ ; therefore,  $V_{MON}$  should be measured with a high-impedance input.

## POWER-DOWN MODE

The DAC8234 implements a group power-down feature to reduce power consumption in case some channels are idle. When the power-down bit (PD-A and/or PD-B) in the Command Register is set to '1', the corresponding group goes into a power-down state. During power-down, the reference buffer and output buffers of that group are powered down and the corresponding analog outputs are set to 0V through an internal 10k $\Omega$  resistor to AGND. The contents of the internal registers do not change, and the bus interface remains active in order to continue communication and receive commands from the host controller. Any internal register can be read from or written to. The host controller can wake the device from power-down mode and return to normal operating mode by clearing the power-down bit (PD-A and/or PD-B) in the Command Register. Recovery completes in approximately 50 $\mu$ s.

## POWER-SUPPLY SEQUENCING

In order to ensure proper initialization of the DAC8234, the digital supplies ( $DV_{DD}$  and  $IOV_{DD}$ ) and logic inputs (UNI/BIP-x) must be applied before  $AV_{SS}$  and  $AV_{DD}$ . Additionally,  $AV_{SS}$  must be applied before  $AV_{DD}$  unless both can ramp up at the same time. REF-x should be applied after  $AV_{DD}$  comes up in order to make sure the ESD protection circuitry does not turn on.

## GENERAL-PURPOSE INPUT/OUTPUT PINS (GPIO-0, -1)

The GPIO-0 and GPIO-1 pins are general-purpose, bidirectional, digital input/output (I/O) signals, as Figure 42 shows. These pins can receive an input or produce an output. When the GPIO-n pin acts as an output, it has an open-drain, and the status is determined by the corresponding GPIO-n bit of the Command Register. The output status is high impedance when the GPIO-n bit is set to '1', and is logic low when the GPIO-n bit is cleared ('0'). Note that a 10k $\Omega$  pullup resistor is required when using the GPIO-n pin as an output.

To use the GPIO-n pin as an input, the GPIO-n bits in the Command Register must be set to '1'. When the GPIO-n pin acts as input, the digital value on the pin is acquired by reading the GPIO-n bit.

After a power-on reset or any forced hardware or software reset, all GPIO-n bits are set to '1', and the GPIO-n pin goes to a high-impedance state.

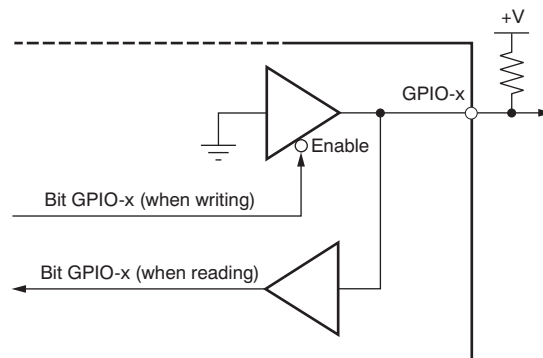

Figure 42. GPIO Pins



## SERIAL INTERFACE

The DAC8234 is controlled over a versatile, three-wire serial interface that operates at clock rates of up to 50MHz and is compatible with SPI, QSPI™, Microwire™, and DSP™ standards.

### SPI Shift Register

The SPI Shift Register is 24 bits wide. Data are loaded into the device MSB first as a 24-bit word under the control of the serial clock input, SCLK. The falling edge of  $\overline{CS}$  starts the communication cycle. Data are latched into the SPI Shift Register on the falling edge of SCLK while  $\overline{CS}$  is low. When  $\overline{CS}$  is high, SCLK is blocked, SDI is ignored, and the SDO line is in a high-impedance state. The contents of the SPI Shift Register are loaded into the addressed internal register on the rising edge of  $\overline{CS}$ . The SPI Shift Register consists of a read/write bit, four register address bits, 14 data bits, and five reserved bits, as shown in [Table 2](#). The timing for this operation is shown in the [Timing Diagrams](#) section. When the device is loaded, the command is decoded, and the new data are transferred into the proper data registers.

The serial interface works with both continuous and non-continuous serial clocks. A continuous SCLK source can only be used if  $\overline{CS}$  is held low for the correct number of clock cycles. In gated clock mode, a burst clock containing the exact number of clock cycles must be used and  $\overline{CS}$  must be taken high after the final clock in order to latch the data.

### Stand-Alone Operation

The first falling edge of  $\overline{CS}$  starts the operation cycle. Exactly 24 falling clock edges must be applied before  $\overline{CS}$  is brought back high again. If  $\overline{CS}$  is brought high before the 24th falling SCLK edge, then the data are ignored. If more than 24 falling SCLK edges are applied before  $\overline{CS}$  is brought high, then the last 24 bits are considered. The addressed internal register is updated from the Shift Register on the rising edge of  $\overline{CS}$ . In order for another serial transfer to take place,  $\overline{CS}$  must be brought low again.

When the data have been transferred into the chosen register of the addressed DAC, all DAC latches and analog outputs can be updated by taking the  $\overline{LDAC}$  pin low or setting the LD bit in the Command Register.

### Daisy-Chain Operation

For systems that contain more than one device, the SDO pin can be used to daisy-chain multiple devices together. Daisy-chain operation can be useful in system diagnostics and in reducing the number of serial interface lines. Note that before daisy-chain operation can begin, the SDO pin must be enabled by clearing the SDO disable bit in the Command Register (DSDO = '0'). By default, this bit is cleared after power-on or reset. The first falling edge of  $\overline{CS}$  starts the operation cycle. SCLK is continuously applied to the input shift register when  $\overline{CS}$  is low. If more than 24 clock pulses are applied, the data ripple out of the shift register and appear on the SDO line. These data are clocked out on the rising edge of SCLK and are valid on the falling edge. By connecting the SDO output of the first device to the SDI input of the next device in the chain, a multiple-device interface is constructed. Each device in the system requires 24 clock pulses. Therefore, the total number of clock cycles must equal  $24 \times N$ , where  $N$  is the total number of DAC8234s in the chain. When the serial transfer to all devices is complete,  $\overline{CS}$  is taken high. This action latches data from the SPI shift register into the device input register of each device in the daisy-chain, and prevents any further data from being clocked in.

### Read-Back Operation

The READ command is used to start read-back operation. However, before read-back operation can be initiated, the SDO pin must be enabled by clearing the DSDO bit in the Command Register (DSDO = '0'); this bit is cleared by default. Read-back operation is then started by executing a READ command (R/W bit = '1'; see Table 2). Bits A3 to A0 in the READ command select the register to be read. The remaining data in the command are *don't care* bits. During the next SPI operation, the data that appear on the SDO output are from the previously addressed register. For a read of a single register, a NOP command can be used to clock out the data from the selected register on SDO. Multiple registers can be read if multiple READ commands are issued. The readback diagram in Figure 43 shows the read-back sequence. The read-back data format is the same format as what was used to write to the device.

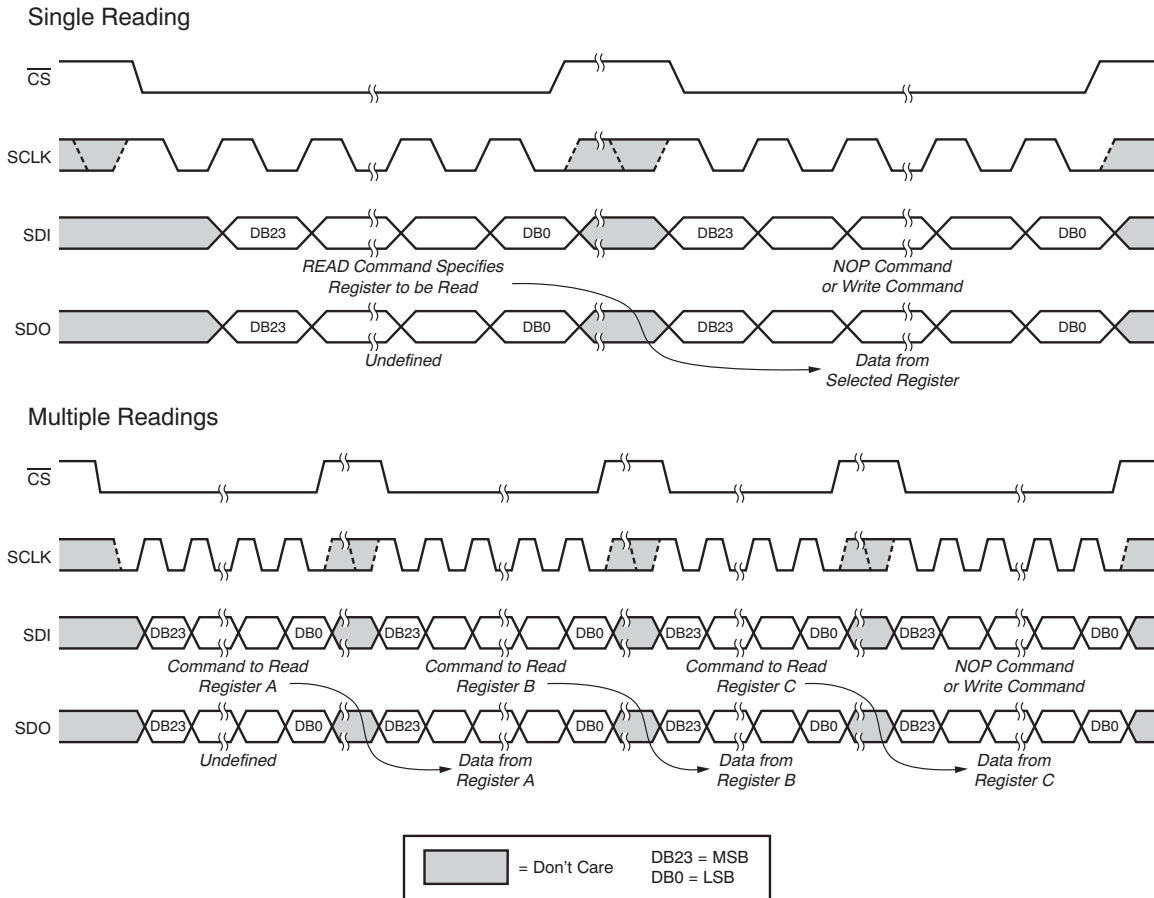

Figure 43. Read-Back Operation

## SPI SHIFT REGISTER

The SPI Shift Register is 24 bits wide, as shown in [Table 2](#). By default, the SPI shift register resets to 000000h at power-on or after a reset.

**Table 2. SPI Shift Register Format**

MSB									
DB23	DB22	DB21	DB20	DB19	DB18	DB17	DB16	DB15:DB2	DB1:DB0
R/ $\overline{W}$	0	0	0	A3	A2	A1	A0	DATA	Rsvd <sup>(1)</sup>

(1) Writing to a reserved bit has no effect; reading the bit returns '0'.

R/ $\overline{W}$ —Indicates a read from or a write to the addressed register.

R/ $\overline{W}$  = '0' sets a write operation and the data are written to the specified register.

R/ $\overline{W}$  = '1' sets a read-back operation. For read operation, bits A3 to A0 select the register to be read. The remaining are *don't care* bits. During the next SPI operation, the data appearing on SDO pin are from the previously addressed register.

[A3:A0]—Address bits that specify which register is accessed.

DATA—14 data bits

All DAC8234 registers (command registers and data registers) are 16-bit. [Table 3](#) shows the register map.

**Table 3. Register Map**

ADDRESS BITS				DATA BITS													REGISTER
A3	A2	A1	A0	DB15	DB14	DB13	DB12	DB11	DB10	DB9	DB8	DB7	DB6	DB5:DB2	DB1:DB0		
0	0	0	0	A/B	LD	RST	PD-A	PD-B	Rsvd <sup>(1)</sup>	GPIO-1	GPIO-0	DSDO	NOP	GAIN Bits	Rsvd <sup>(1)</sup>	Command Register	
0	0	0	1	MDAC-3	MDAC-2	MDAC-1	MDAC-0	AIN	Reserved <sup>(1)</sup>							Monitor Register	
0	1	0	0	D13:D0											Rsvd <sup>(1)</sup>	DAC-0	
0	1	0	1	D13:D0											Rsvd <sup>(1)</sup>	DAC-1	
0	1	1	0	D13:D0											Rsvd <sup>(1)</sup>	DAC-2	
0	1	1	1	D13:D0											Rsvd <sup>(1)</sup>	DAC-3	
1	0	0	0	Reserved <sup>(1)</sup>							Z8:Z0						Zero Register-0
1	0	0	1	Reserved <sup>(1)</sup>							Z8:Z0						Zero Register-1
1	0	1	0	Reserved <sup>(1)</sup>							Z8:Z0						Zero Register-2
1	0	1	1	Reserved <sup>(1)</sup>							Z8:Z0						Zero Register-3
1	1	0	0	Reserved <sup>(1)</sup>							G7:G0						Gain Register-0
1	1	0	1	Reserved <sup>(1)</sup>							G7:G0						Gain Register-1
1	1	1	0	Reserved <sup>(1)</sup>							G7:G0						Gain Register-2
1	1	1	1	Reserved <sup>(1)</sup>							G7:G0						Gain Register-3
Others				Reserved <sup>(1)</sup>													—

(1) Writing to a reserved bit has no effect; reading the bit returns '0'.

## INTERNAL REGISTERS

The DAC8234 internal registers consist of the Command Register, the Monitor Register, the DAC Input Data Registers, the Zero Registers, and the Gain Registers.

**Command Register.** Default = 033Ch.

The Command Register determines the actions performed by the DAC8234.

**Table 4. Command Register**

BIT	NAME	DEFAULT VALUE	DESCRIPTION
DB15	A/B	0	A/B bit. When A/B = '0', reading DAC-x returns the value in the Input Data Register. When A/B = '1', reading DAC-x returns the value in the DAC latch.
DB14	LD	0	Synchronously update DACs bit. Functions in the same manner as the $\overline{\text{LDAC}}$ pin. When $\overline{\text{LDAC}}$ is tied high, set LD = '1' at any time after the write operation and the correction process proceeds to synchronously update all DAC latches with the content of the corresponding Input Data Register, and sets $V_{\text{OUT}}$ to a new level. The DAC8234 updates the DAC latch only if it has been accessed since the last time $\overline{\text{LDAC}}$ was brought low or the LD bit was set to '1', thereby eliminating unnecessary glitch. Any DACs that were not accessed are not reloaded. After updating, the bit returns to '0'. Refer to the <a href="#">Updating Via <math>\overline{\text{LDAC}}</math></a> section for details. When the $\overline{\text{LDAC}}$ pin is tied low, the LD bit is ignored.
DB13	RST	0	Software reset bit. Set the RST bit to '1' to reset the device; functions the same as a hardware reset. After reset completes, the RST bit returns to '0'.
DB12	PD-A	0	Power-down bit for Group A. Setting the PD-A bit to '1' places Group A (DAC-0 and DAC-1) into power-down operation. All output buffers are in Hi-Z and all analog outputs ( $V_{\text{OUT-X}}$ ) connect to AGND through an internal 10k $\Omega$ resistor. The interface remains active. Setting the PD-A bit to '0' returns Group A to normal operation.
DB11	PD-B	0	Power-down bit for Group B. Setting the PD-B bit to '1' places Group B (DAC-2 and DAC-3) into power-down operation. All output buffers are in Hi-Z and all analog outputs ( $V_{\text{OUT-X}}$ ) connect to AGND through an internal 10k $\Omega$ resistor. The interface remains active. Setting the PD-B bit to '0' returns Group B to normal operation.
DB10	Rsvd	0	Reserved. Writing to this bit has no effect; reading this bit returns '0'.
DB9	GPIO-1	1	GPIO-1 status bit. Writing a '1' to the GPIO-1 bit puts the GPIO-1 pin into a Hi-Z state (default). Writing a '0' to the GPIO-1 bit forces the GPIO-1 pin low. When reading this bit, the digital value on the GPIO-1 pin is acquired.
DB8	GPIO-0	1	GPIO-0 status bit. Writing a '1' to the GPIO-0 bit puts the GPIO-1 pin into a Hi-Z state (default). Writing a '0' to the GPIO-0 bit forces the GPIO-1 pin low. When reading this bit, the digital value on the GPIO-0 pin is acquired.
DB7	DSDO	0	Disable SDO bit. Set the DSDO bit to '0' to enable the SDO pin (default). The SDO pin works as a normal SPI output. Set the DSDO bit to '1' to disable the SDO pin. The SDO pin is always in a Hi-Z state regardless of the status of the $\overline{\text{CS}}$ pin is.
DB6	NOP	0	No operation bit. Writing '0' or '1' to this bit has no effect and the bit returns to '0' at the end of the write operation. Reading the bit always returns '0'.
DB5	GAIN-3	1	DAC-3 gain bit. Set the GAIN-3 bit to '1' for a gain = 4. Set the GAIN-3 bit to '0' for a gain = 2.
DB4	GAIN-2	1	DAC-2 gain bit. Set the GAIN-2 bit to '1' for a gain = 4. Set the GAIN-2 bit to '0' for a gain = 2.
DB3	GAIN-1	1	DAC-1 gain bit. Set the GAIN-1 bit to '1' for a gain = 4. Set the GAIN-1 bit to '0' for a gain = 2.
DB2	GAIN-0	1	DAC-0 gain bit. Set the GAIN-0 bit to '1' for a gain = 4. Set the GAIN-0 bit to '0' for a gain = 2.
DB1:DB0	—	0	Reserved. Writing to these bits has no effect; reading these bits returns '0'.

**Monitor Register.** Default = 0000h.

The Monitor Register selects one of the four DAC outputs or the external signal AIN that is to be monitored through the  $V_{MON}$  pin. Only one bit can be set to '1' at a time. When all bits = '0', the monitor is disabled and  $V_{MON}$  is placed in a high-impedance state. The default value after power-on or reset is 0000h.

**Table 5. Monitor Register**

DB15	DB14	DB13	DB12	DB11	DB10:DB0	$V_{MON}$ CONNECTS TO
0	0	0	0	1	Reserved <sup>(1)</sup>	AIN
0	0	0	1	0	Reserved <sup>(1)</sup>	DAC-0
0	0	1	0	0	Reserved <sup>(1)</sup>	DAC-1
0	1	0	0	0	Reserved <sup>(1)</sup>	DAC-2
1	0	0	0	0	Reserved <sup>(1)</sup>	DAC-3
0	0	0	0	0	Reserved <sup>(1)</sup>	Monitor disabled, Hi-Z (default)

(1) Writing to a reserved bit has no effect; reading the bit returns '0'.

**Input Data Register for DAC-n (where n = 0, 1, 2, or 3).** Default = 0000h.

This register stores the DAC data written to the device. When the data are loaded into the corresponding DAC latch, the DAC output changes to the new level defined by the DAC data. The default value after power-on or reset is 0000h.

For bipolar operation, the input data format is always twos complement. For unipolar operation, the input data format is always straight binary.

**Table 6. DAC-n (n = 0, 1, 2, or 3) Input Data Register**

MSB														LSB	
DB15	DB14	DB13	DB12	DB11	DB10	DB9	DB8	DB7	DB6	DB5	DB4	DB3	DB2	DB1	DB0
D13 <sup>(1)</sup>	D12	D11	D10	D9	D8	D7	D6	D5	D4	D3	D2	D1	D0	Reserved <sup>(2)</sup>	

(1) D13:D0 are the DAC data bits.

(2) Writing to a reserved bit has no effect; reading the bit returns '0'.

**Table 7. DAC Output vs Twos Complement Code for Bipolar Output Operation**

TWOS COMPLEMENT CODE (D13:D0)	OUTPUT	DESCRIPTION
0111 1111 1111 11	$+0.5 \times \text{Gain} \times V_{REF} \times (8191/8192)$	+Full-Scale – 1 LSB
... ..	... ..	... ..
0000 0000 0000 01	$+0.5 \times \text{Gain} \times V_{REF} \times (1/8192)$	+1 LSB
0000 0000 0000 00	0	Zero
1111 1111 1111 11	$-0.5 \times \text{Gain} \times V_{REF} \times (1/8192)$	-1 LSB
... ..	... ..	... ..
1000 0000 0000 00	$-0.5 \times \text{Gain} \times V_{REF} \times (8192/8192)$	-Full-Scale

**Table 8. DAC Output vs Straight Binary Code for Unipolar Output Operation**

STRAIGHT BINARY CODE (D13:D0)	OUTPUT	DESCRIPTION
1111 1111 1111 11	$\text{Gain} \times V_{REF} \times (16383/16384)$	+Full-Scale – 1 LSB
... ..	... ..	... ..
1000 0000 0000 00	$\text{Gain} \times V_{REF} \times (8192/16384)$	1/2 Full-Scale
0111 1111 1111 11	$\text{Gain} \times V_{REF} \times (8191/16384)$	1/2 Full-Scale – 1 LSB
... ..	... ..	... ..
0000 0000 0000 00	0	Zero

**Zero Register n (where n = 0, 1, 2, or 3).** Default = 0000h.

The Zero Register stores the user-calibration data that are used to eliminate the offset error. The data are nine bits wide, 0.03125 LSB/step, and the total adjustment is typically  $-8$  LSB to  $+7.96875$  LSB, or  $\pm 0.0488\%$  of full-scale range. The Zero Register uses a twos complement data format in both bipolar and unipolar modes of operation.

**Table 9. Zero Register**

DB15:DB9	DB8	DB7	DB6	DB5	DB4	DB3	DB2	DB1	DB0
Reserved <sup>(1)</sup>	Z8	Z7	Z6	Z5	Z4	Z3	Z2	Z1	Z0

(1) Writing to a reserved bit has no effect; reading the bit returns '0'.

Z8:Z0—OFFSET BITS	ZERO ADJUSTMENT
011111111	+7.96875 LSB
011111110	+7.9375 LSB
... ..	... ..
000000001	+0.03125 LSB
000000000	0 LSB (default)
111111111	-0.03125 LSB
... ..	... ..
100000001	-7.96875 LSB
100000000	-8 LSB

**Gain Register n (where n = 0, 1, 2, or 3).** Default = 0000h.

The Gain Register stores the user-calibration data that are used to eliminate the gain error. The data are eight bits wide, 0.25 LSB/step, and the total adjustment is typically  $-32$  LSB to  $+31.75$  LSB, or  $\pm 0.195\%$  of full-scale range. The Gain Register uses a twos complement data format in both bipolar and unipolar modes of operation.

**Table 10. Gain Register**

DB15:DB8	DB7	DB6	DB5	DB4	DB3	DB2	DB1	DB0
Reserved <sup>(1)</sup>	G7	G6	G5	G4	G3	G2	G1	G0

(1) Writing to a reserved bit has no effect; reading the bit returns '0'.

G7:G0—GAIN-CODE BITS	GAIN ADJUSTMENT
01111111	+31.75 LSB
01111110	+31.50 LSB
... ..	... ..
00000001	+0.25 LSB
00000000	0 LSB (default)
11111111	-0.25 LSB
... ..	... ..
10000001	-31.75 LSB
10000000	-32 LSB

## APPLICATION INFORMATION

### BASIC OPERATION

The DAC8234 is a highly-integrated device with high-performance reference buffers and output buffers, greatly reducing the printed circuit board (PCB) area and cost. On-chip reference buffers eliminate the need for a negative external reference. Configurable on-chip output buffers support four different output modes. Figure 44 shows a basic application for the DAC8234.

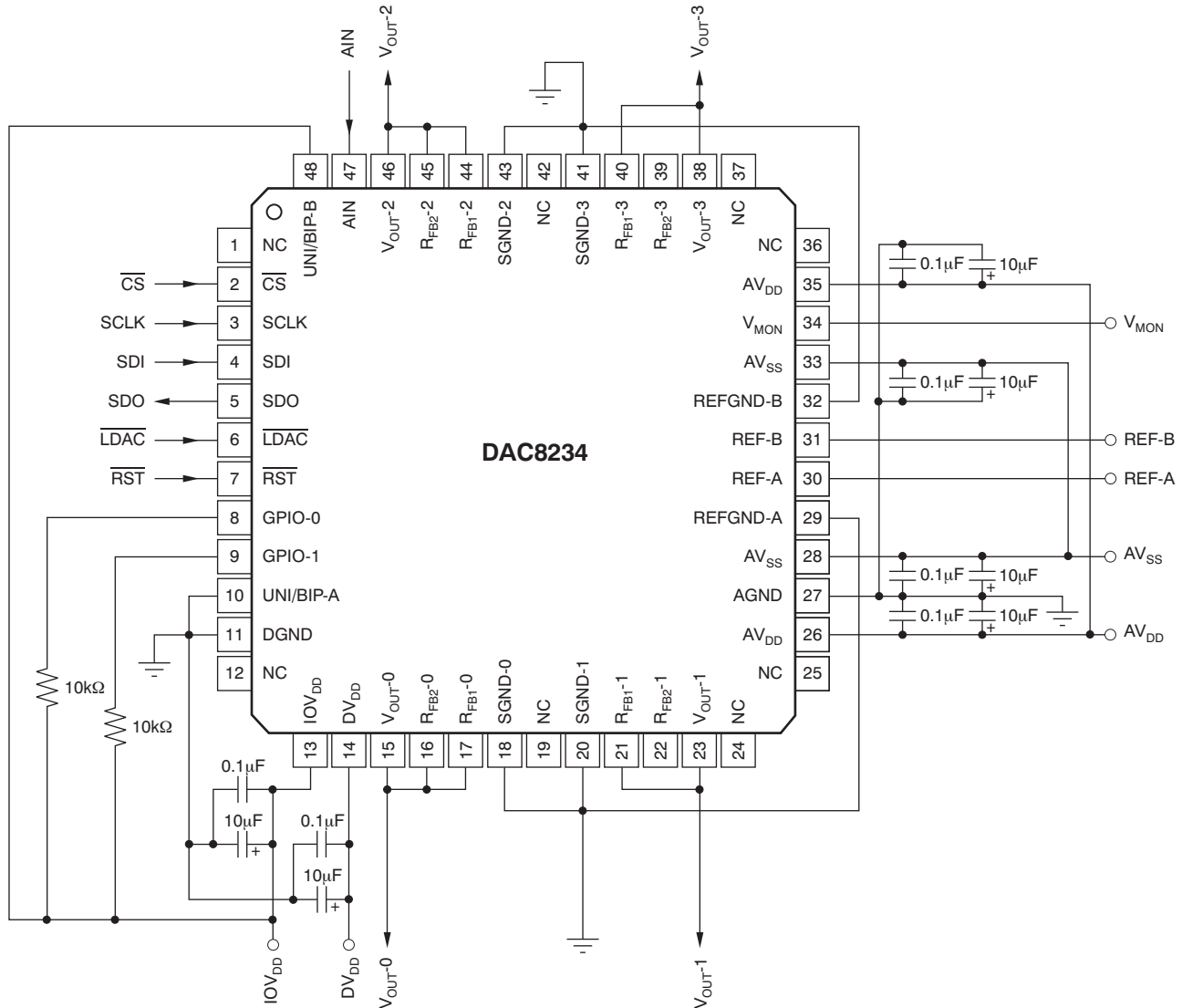

NOTES:  $AV_{DD} = +15V$ ,  $AV_{SS} = -15V$ ,  $DV_{DD} = +5V$ ,  $IOV_{DD} = +1.8$  to  $+5V$ ,  $REF-A = +5V$ , and  $REF-B = +2.5V$ .  
 The gain bits in the Command Register are:  $GAIN-0 = '0'$ ,  $GAIN-1 = '1'$ ,  $GAIN-2 = '0'$ , and  $GAIN-3 = '1'$ .  
 The DACs are set to the following gains:  $DAC-0 = \times 2$ ,  $DAC-1 = \times 4$ ,  $DAC-2 = \times 2$ , and  $DAC-3 = \times 4$ .  
 The output ranges are:  $V_{OUT-0} = -5V$  to  $+5V$ ,  
 $V_{OUT-1} = -10V$  to  $+10V$ ,  
 $V_{OUT-2} = 0V$  to  $+5V$ ,  
 $V_{OUT-3} = 0V$  to  $+10V$ .

Figure 44. Basic Application Example



### USER ZERO- AND GAIN-CALIBRATION

The DAC8234 is trimmed during production for nominal operating conditions to have very low gain error and offset error. However, to trim the offset and gain errors introduced at other conditions of operation or by other components in the signal chain, the DAC8234 has a user zero and gain digital calibration feature for each DAC channel. Figure 45 and Figure 46 illustrate the relationship of zero and gain calibration for the DAC8234 in unipolar output and bipolar output configurations, respectively.

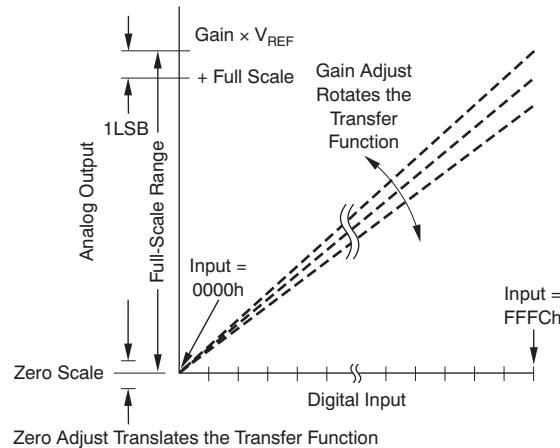

Figure 45. Relationship of Zero and Gain Calibration for a Unipolar Output Configuration

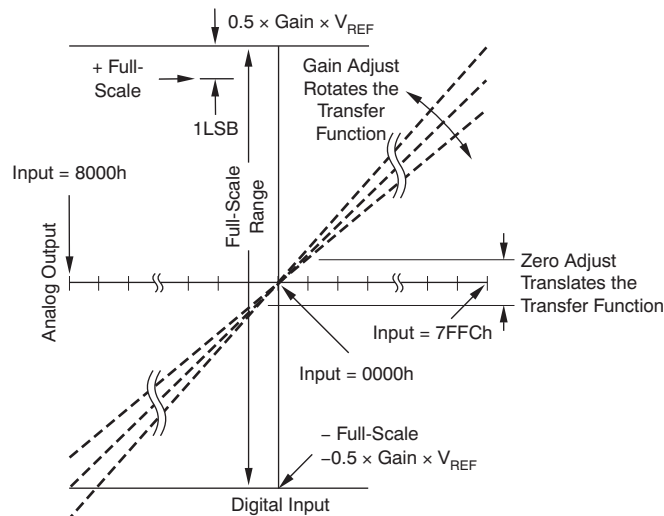

Figure 46. Relationship of Zero and Gain Calibration for a Bipolar Output Configuration

### System Zero Adjust Example

The DAC8234 zero calibration feature can minimize system offset errors to 0.00019% FSR or 38 $\mu$ V over a 20V output range. The total adjustment range is approximately  $\pm 0.0488\%$  of FSR, or  $\pm 9.7$ mV over a 20V output span.

Assuming that the DAC has been set up with a full-scale range of 20V, and the offset error to be eliminated from the signal chain is  $-1$ mV, then the step size =  $0.0000019 \times 20V = 38\mu V$ .

$$\text{Number of Steps of Zero Calibration} = \frac{-1 \times \text{Offset\_Error}}{\text{Step Size}} \quad (3)$$

Where *Offset\_Error* is the value of the offset error to be corrected.

For this example, the number of steps of zero calibration =  $1\text{mV} / 38\mu V \approx 26$ . Therefore, the Zero Register should be coded with the twos complement of 26 = 0 0001 1010.

Suppose the offset error to be eliminated is  $+1$ mV instead; then the number of steps of zero calibration is the twos complement equivalent of  $-26$ , which is 1 1110 0110.

### System Gain Adjust Example

The DAC8234 gain calibration feature can minimize system gain errors to 0.001525% FSR or 305 $\mu$ V over a 20V output range. The total adjustment range is approximately  $\pm 0.195\%$  FSR, or  $-39$ mV to  $+38.7$ mV over a 20V output span.

Assuming that the DAC has been set up with a full-scale range of 20V, and the gain error to be eliminated from the signal chain is  $-10$ mV, then the step size =  $0.00001525 \times 20V = 305\mu V$ .

$$\text{Number of Steps of Gain Calibration} = \frac{-1 \times \text{Gain\_Error}}{\text{Step Size}} \quad (4)$$

Where *Gain\_Error* is the value of the gain error to be corrected.

For this example, the number of steps of the gain calibration =  $10\text{mV} / 305\mu V \approx 33$ . Therefore, the Gain Register should be coded with the twos complement of 33 = 0010 0001.

Suppose the gain error to be eliminated is  $+10$ mV instead; then the number of steps of Gain calibration is the twos complement equivalent of  $-33$ , which is 1101 1111.

## LAYOUT AND GROUNDING

Precision analog circuits require careful layout, adequate bypass capacitors, and a clean, well-regulated power supply to obtain the best possible dc and ac performance. A careful consideration of the power-supply and ground-return layout helps to ensure the rated performance.

The PCB must be designed so that the analog and digital sections are separated and confined to certain areas of the board. Fast switching signals, such as clocks, must be shielded with the digital ground to avoid radiating noise to other sections of the board, and must never be run near the reference inputs. It is essential to minimize noise on the reference inputs because it couples through to the DAC output. Avoid crossover of digital and analog signals. Traces on opposite sides of the board must run at right angles to each other. This configuration reduces the effects of feedthrough on the board. A microstrip technique may be considered, but may not always be possible with a double-sided board. In this technique, the component side of the board is dedicated to the ground plane, and signal traces are placed on the solder side.

DGND is the return path for digital currents and AGND is the analog power ground for the DAC. For the best ac performance, care should be taken to connect DGND and AGND with very low resistance back to the supply ground. If multiple devices require an AGND-to-DGND connection, the connection must be made at one point only. The star ground point must be established as close as possible to the device. Each DAC has a ground pin (SGND-x) that must be connected directly to the corresponding reference ground in low-impedance paths to achieve the best performance. SGND-0 and SGND-1 must be connected with REFGND-A, and SGND-2 and SGND-3 must be connected with REFGND-B. It is critical that this trace resistance be extremely small in order to prevent the voltage drops across the path from affecting device linearity and gain performance. The reference ground pins, REFGND-A and REFGND-B, must be connected to analog ground AGND.

## POWER-SUPPLY NOISE

The DAC8234 should have ample supply bypassing of 1 $\mu$ F to 10 $\mu$ F in parallel with 0.1 $\mu$ F on each supply, located as close to the package as possible; ideally, placed next to the device. The 1 $\mu$ F to 10 $\mu$ F capacitors must be a tantalum-bead type. The 0.1 $\mu$ F capacitor must have low effective series resistance (ESR) and low effective series inductance (ESI), such as common ceramic types that provide a low-impedance path to ground at high frequencies to handle transient currents because of internal logic switching. The power-supply lines must use traces as wide as possible to provide low-impedance paths and reduce the effects of glitches on the power-supply line. Apart from these considerations, the wideband noise on the AV<sub>DD</sub>, AV<sub>SS</sub>, DV<sub>DD</sub>, and IOV<sub>DD</sub> supplies should be filtered before being fed to the DAC in order to obtain the best noise performance possible.

## PRECISION VOLTAGE REFERENCE SELECTION

To achieve the optimum performance from the DAC8234 over its full operating temperature range, a precision voltage reference must be used. Consideration should be given to the selection of a precision voltage reference. The DAC8234 has two reference inputs, REF-A and REF-B. The voltages applied to the reference inputs are used to provide a buffered positive and negative reference for the DAC cores. Therefore, any error in the voltage reference is reflected in the outputs of the device. There are four possible sources of error to consider when choosing a voltage reference for high-accuracy applications: initial accuracy, temperature coefficient of the output voltage, long-term drift, and output voltage noise. Initial accuracy error on the output voltage of an external reference can lead to a full-scale error in the DAC. Therefore, to minimize these errors, a reference with a low initial accuracy error specification is preferred. Long-term drift is a measurement of how much the reference output voltage drifts over time. A reference with a tight, long-term drift specification ensures that the overall solution remains relatively stable over its entire lifetime. The temperature coefficient of a reference output voltage affects INL, DNL, gain error, and zero error. Choose a reference with a tight temperature coefficient specification to reduce the dependence of the DAC output voltage on ambient conditions. In high-accuracy applications that have a relatively low noise budget, reference output voltage noise must be considered. Choosing a reference with as low an output noise voltage as practical for the system resolution required is important. Precision voltage references such as the TI [REF50xx](#) (2V to 5V) and [REF32xx](#) (1.25V to 4V), provide low-drift and high-accuracy reference voltage.

**PACKAGING INFORMATION**

Orderable Device	Status <sup>(1)</sup>	Package Type	Package Drawing	Pins	Package Qty	Eco Plan <sup>(2)</sup>	Lead/Ball Finish	MSL Peak Temp <sup>(3)</sup>
DAC8234SPFB	ACTIVE	TQFP	PFB	48	250	Green (RoHS & no Sb/Br)	CU NIPDAU	Level-2-260C-1 YEAR
DAC8234SPFBR	ACTIVE	TQFP	PFB	48	1000	Green (RoHS & no Sb/Br)	CU NIPDAU	Level-2-260C-1 YEAR
DAC8234SRHAR	ACTIVE	QFN	RHA	40	2500	Green (RoHS & no Sb/Br)	CU NIPDAU	Level-2-260C-1 YEAR
DAC8234SRHAT	ACTIVE	QFN	RHA	40	250	Green (RoHS & no Sb/Br)	CU NIPDAU	Level-2-260C-1 YEAR

<sup>(1)</sup> The marketing status values are defined as follows:

**ACTIVE:** Product device recommended for new designs.

**LIFEBUY:** TI has announced that the device will be discontinued, and a lifetime-buy period is in effect.

**NRND:** Not recommended for new designs. Device is in production to support existing customers, but TI does not recommend using this part in a new design.

**PREVIEW:** Device has been announced but is not in production. Samples may or may not be available.

**OBSOLETE:** TI has discontinued the production of the device.

<sup>(2)</sup> Eco Plan - The planned eco-friendly classification: Pb-Free (RoHS), Pb-Free (RoHS Exempt), or Green (RoHS & no Sb/Br) - please check <http://www.ti.com/productcontent> for the latest availability information and additional product content details.

**TBD:** The Pb-Free/Green conversion plan has not been defined.

**Pb-Free (RoHS):** TI's terms "Lead-Free" or "Pb-Free" mean semiconductor products that are compatible with the current RoHS requirements for all 6 substances, including the requirement that lead not exceed 0.1% by weight in homogeneous materials. Where designed to be soldered at high temperatures, TI Pb-Free products are suitable for use in specified lead-free processes.

**Pb-Free (RoHS Exempt):** This component has a RoHS exemption for either 1) lead-based flip-chip solder bumps used between the die and package, or 2) lead-based die adhesive used between the die and leadframe. The component is otherwise considered Pb-Free (RoHS compatible) as defined above.

**Green (RoHS & no Sb/Br):** TI defines "Green" to mean Pb-Free (RoHS compatible), and free of Bromine (Br) and Antimony (Sb) based flame retardants (Br or Sb do not exceed 0.1% by weight in homogeneous material)

<sup>(3)</sup> MSL, Peak Temp. -- The Moisture Sensitivity Level rating according to the JEDEC industry standard classifications, and peak solder temperature.

**Important Information and Disclaimer:**The information provided on this page represents TI's knowledge and belief as of the date that it is provided. TI bases its knowledge and belief on information provided by third parties, and makes no representation or warranty as to the accuracy of such information. Efforts are underway to better integrate information from third parties. TI has taken and continues to take reasonable steps to provide representative and accurate information but may not have conducted destructive testing or chemical analysis on incoming materials and chemicals. TI and TI suppliers consider certain information to be proprietary, and thus CAS numbers and other limited information may not be available for release.

In no event shall TI's liability arising out of such information exceed the total purchase price of the TI part(s) at issue in this document sold by TI to Customer on an annual basis.

TAPE AND REEL INFORMATION

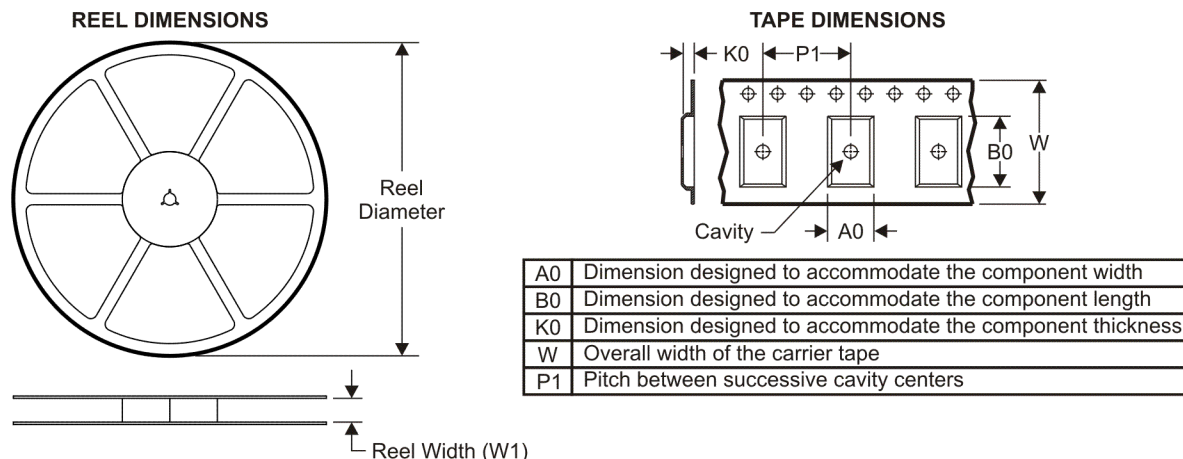

QUADRANT ASSIGNMENTS FOR PIN 1 ORIENTATION IN TAPE

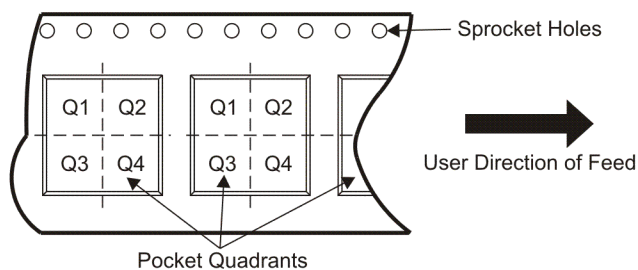

\*All dimensions are nominal

Device	Package Type	Package Drawing	Pins	SPQ	Reel Diameter (mm)	Reel Width W1 (mm)	A0 (mm)	B0 (mm)	K0 (mm)	P1 (mm)	W (mm)	Pin1 Quadrant
DAC8234SPFBR	TQFP	PFB	48	1000	330.0	16.4	9.6	9.6	1.5	12.0	16.0	Q2
DAC8234SRHAR	QFN	RHA	40	2500	330.0	16.4	6.3	6.3	1.5	12.0	16.0	Q2
DAC8234SRHAT	QFN	RHA	40	250	330.0	16.4	6.3	6.3	1.5	12.0	16.0	Q2

**TAPE AND REEL BOX DIMENSIONS**



\*All dimensions are nominal

Device	Package Type	Package Drawing	Pins	SPQ	Length (mm)	Width (mm)	Height (mm)
DAC8234SPFBR	TQFP	PFB	48	1000	346.0	346.0	33.0
DAC8234SRHAR	QFN	RHA	40	2500	333.2	345.9	28.6
DAC8234SRHAT	QFN	RHA	40	250	333.2	345.9	28.6

PFB (S-PQFP-G48)

PLASTIC QUAD FLATPACK

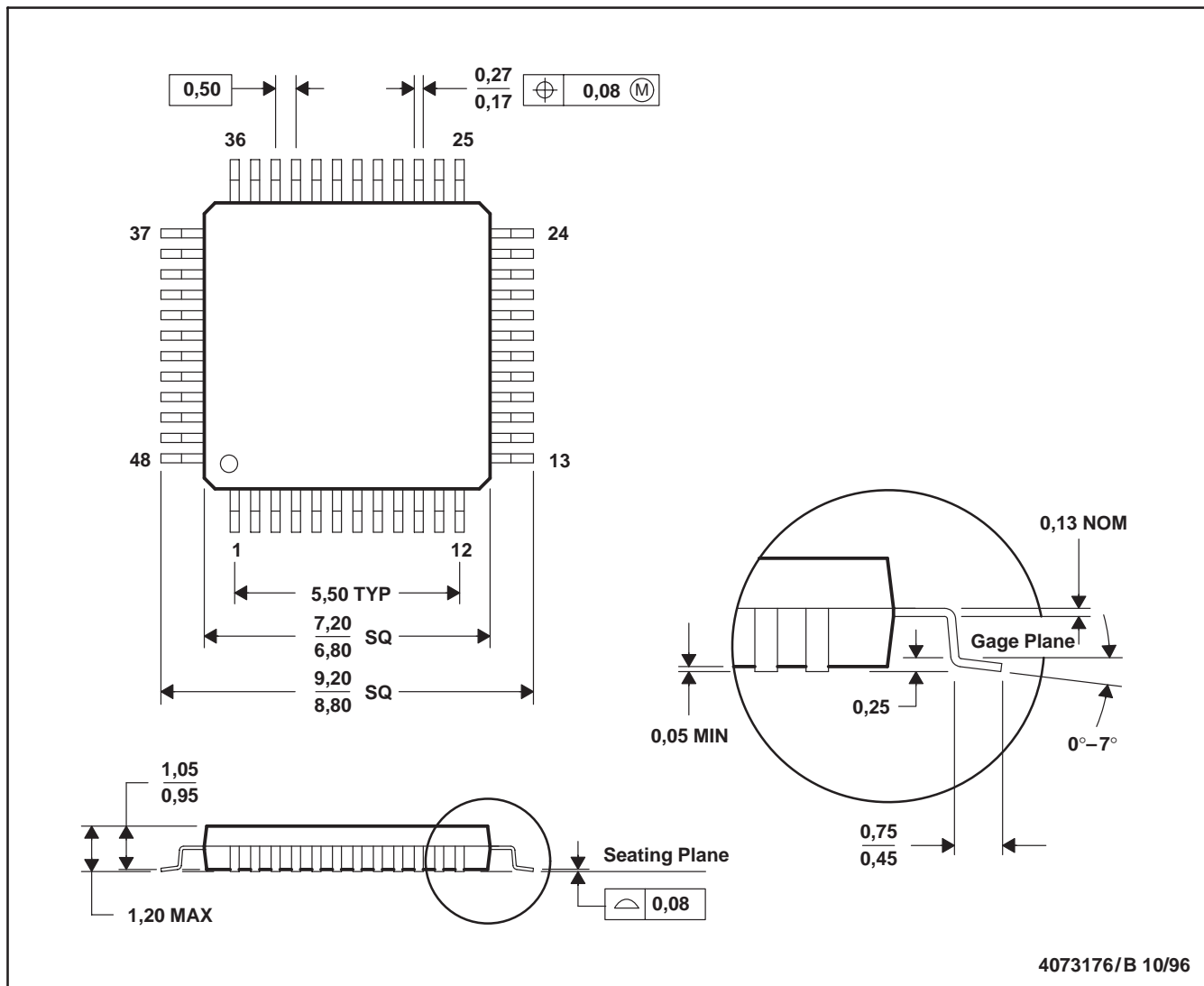

- NOTES: A. All linear dimensions are in millimeters.  
 B. This drawing is subject to change without notice.  
 C. Falls within JEDEC MS-026





[查询"DAC8234SRHAR"供应商](#)

RHA (S-PQFP-N40)

PLASTIC QUAD FLATPACK

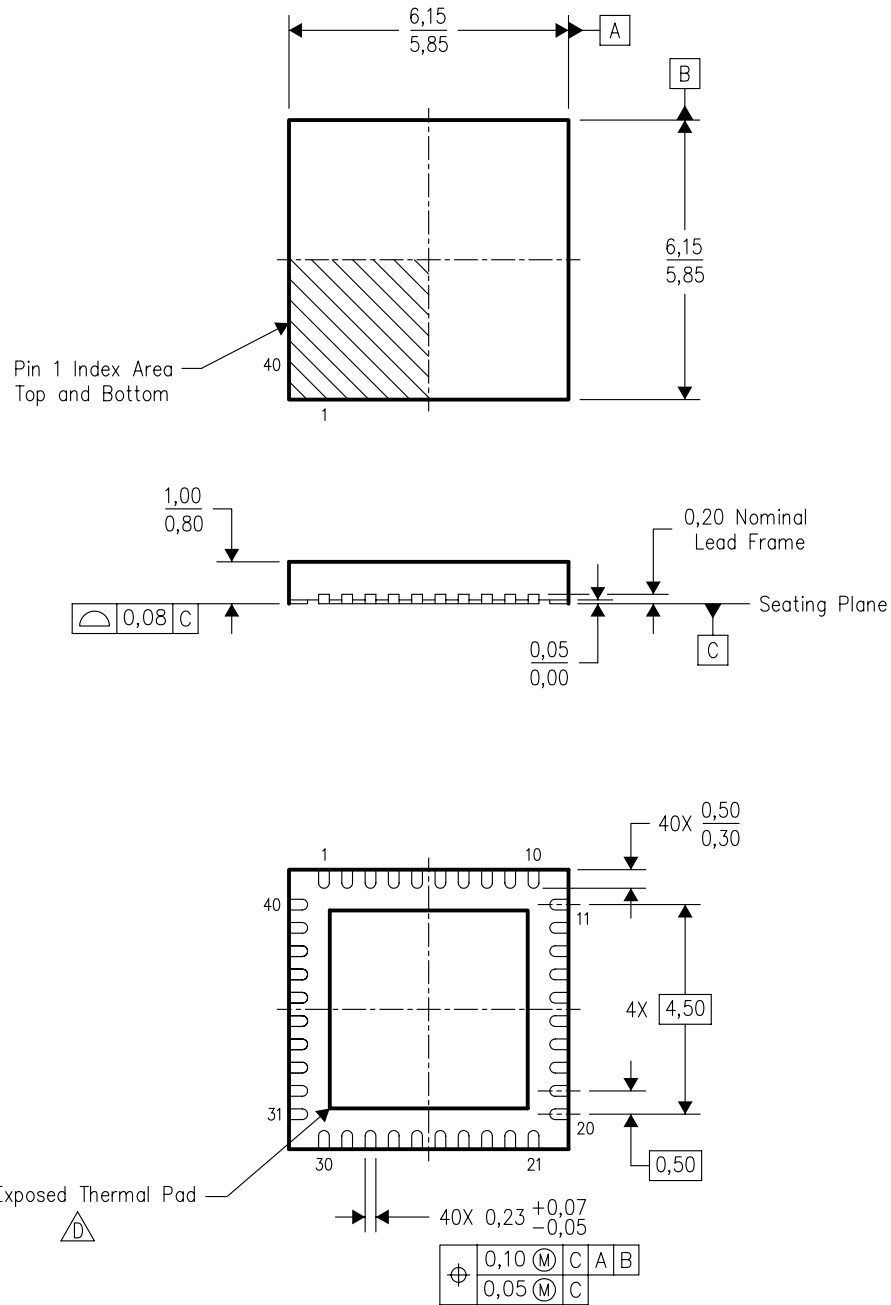

Bottom View

4204276/C 12/2004

- NOTES:
- A. All linear dimensions are in millimeters. Dimensioning and tolerancing per ASME Y14.5M-1994.
  - B. This drawing is subject to change without notice.
  - C. QFN (Quad Flatpack No-Lead) Package configuration.
  -  The package thermal pad must be soldered to the board for thermal and mechanical performance. See the Product Data Sheet for details regarding the exposed thermal pad dimensions.
  - E. Package complies to JEDEC MO-220 variation VJJD-2.

THERMAL INFORMATION

This package incorporates an exposed thermal pad that is designed to be attached directly to an external heatsink. The thermal pad must be soldered directly to the printed circuit board (PCB). After soldering, the PCB can be used as a heatsink. In addition, through the use of thermal vias, the thermal pad can be attached directly to the appropriate copper plane shown in the electrical schematic for the device, or alternatively, can be attached to a special heatsink structure designed into the PCB. This design optimizes the heat transfer from the integrated circuit (IC).

For information on the Quad Flatpack No-Lead (QFN) package and its advantages, refer to Application Report, QFN/SON PCB Attachment, Texas Instruments Literature No. SLUA271. This document is available at [www.ti.com](http://www.ti.com).

The exposed thermal pad dimensions for this package are shown in the following illustration.

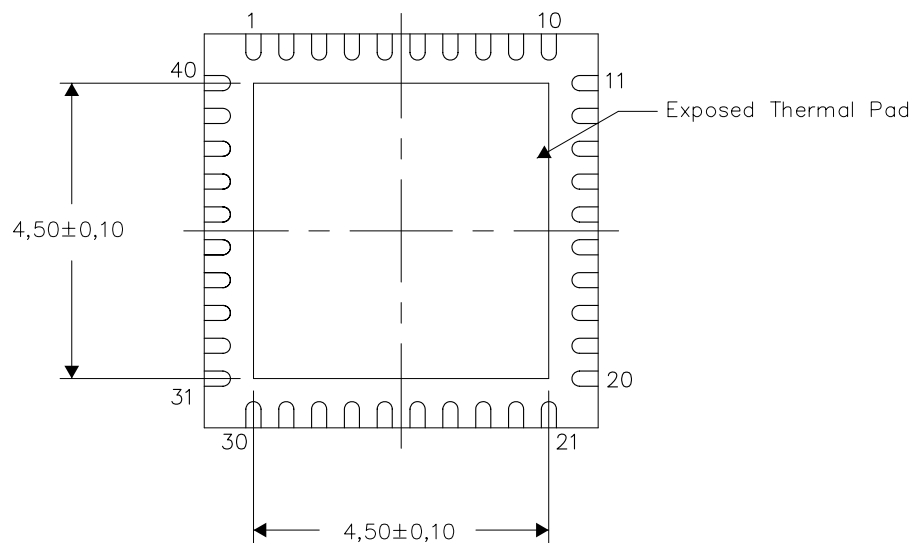

Bottom View

NOTE: All linear dimensions are in millimeters

Exposed Thermal Pad Dimensions

RHA (S-PVQFN-N40)

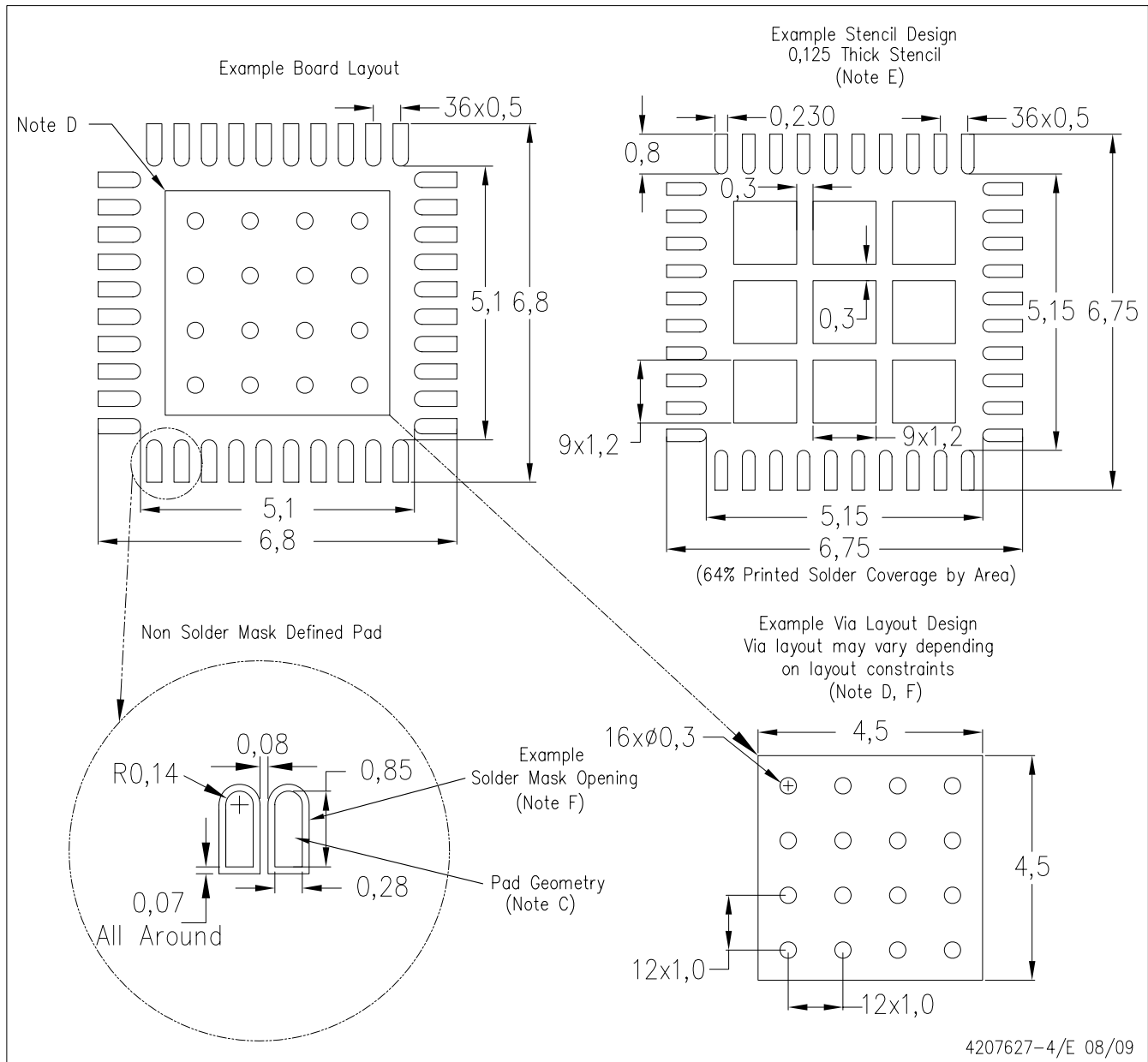

- NOTES:
- All linear dimensions are in millimeters.
  - This drawing is subject to change without notice.
  - Publication IPC-7351 is recommended for alternate designs.
  - This package is designed to be soldered to a thermal pad on the board. Refer to Application Note, Quad Flat-Pack Packages, Texas Instruments Literature No. SLUA271, and also the Product Data Sheets for specific thermal information, via requirements, and recommended board layout. These documents are available at [www.ti.com](http://www.ti.com) <<http://www.ti.com>>.
  - Laser cutting apertures with trapezoidal walls and also rounding corners will offer better paste release. Customers should contact their board assembly site for stencil design recommendations. Refer to IPC 7525 for stencil design considerations.
  - Customers should contact their board fabrication site for recommended solder mask tolerances and via tenting recommendations for vias placed in the thermal pad.

## IMPORTANT NOTICE

Texas Instruments Incorporated and its subsidiaries (TI) reserve the right to make corrections, modifications, enhancements, improvements, and other changes to its products and services at any time and to discontinue any product or service without notice. Customers should obtain the latest relevant information before placing orders and should verify that such information is current and complete. All products are sold subject to TI's terms and conditions of sale supplied at the time of order acknowledgment.

TI warrants performance of its hardware products to the specifications applicable at the time of sale in accordance with TI's standard warranty. Testing and other quality control techniques are used to the extent TI deems necessary to support this warranty. Except where mandated by government requirements, testing of all parameters of each product is not necessarily performed.

TI assumes no liability for applications assistance or customer product design. Customers are responsible for their products and applications using TI components. To minimize the risks associated with customer products and applications, customers should provide adequate design and operating safeguards.

TI does not warrant or represent that any license, either express or implied, is granted under any TI patent right, copyright, mask work right, or other TI intellectual property right relating to any combination, machine, or process in which TI products or services are used. Information published by TI regarding third-party products or services does not constitute a license from TI to use such products or services or a warranty or endorsement thereof. Use of such information may require a license from a third party under the patents or other intellectual property of the third party, or a license from TI under the patents or other intellectual property of TI.

Reproduction of TI information in TI data books or data sheets is permissible only if reproduction is without alteration and is accompanied by all associated warranties, conditions, limitations, and notices. Reproduction of this information with alteration is an unfair and deceptive business practice. TI is not responsible or liable for such altered documentation. Information of third parties may be subject to additional restrictions.

Resale of TI products or services with statements different from or beyond the parameters stated by TI for that product or service voids all express and any implied warranties for the associated TI product or service and is an unfair and deceptive business practice. TI is not responsible or liable for any such statements.

TI products are not authorized for use in safety-critical applications (such as life support) where a failure of the TI product would reasonably be expected to cause severe personal injury or death, unless officers of the parties have executed an agreement specifically governing such use. Buyers represent that they have all necessary expertise in the safety and regulatory ramifications of their applications, and acknowledge and agree that they are solely responsible for all legal, regulatory and safety-related requirements concerning their products and any use of TI products in such safety-critical applications, notwithstanding any applications-related information or support that may be provided by TI. Further, Buyers must fully indemnify TI and its representatives against any damages arising out of the use of TI products in such safety-critical applications.

TI products are neither designed nor intended for use in military/aerospace applications or environments unless the TI products are specifically designated by TI as military-grade or "enhanced plastic." Only products designated by TI as military-grade meet military specifications. Buyers acknowledge and agree that any such use of TI products which TI has not designated as military-grade is solely at the Buyer's risk, and that they are solely responsible for compliance with all legal and regulatory requirements in connection with such use.

TI products are neither designed nor intended for use in automotive applications or environments unless the specific TI products are designated by TI as compliant with ISO/TS 16949 requirements. Buyers acknowledge and agree that, if they use any non-designated products in automotive applications, TI will not be responsible for any failure to meet such requirements.

Following are URLs where you can obtain information on other Texas Instruments products and application solutions:

### Products

Amplifiers	<a href="http://amplifier.ti.com">amplifier.ti.com</a>
Data Converters	<a href="http://dataconverter.ti.com">dataconverter.ti.com</a>
DLP® Products	<a href="http://www.dlp.com">www.dlp.com</a>
DSP	<a href="http://dsp.ti.com">dsp.ti.com</a>
Clocks and Timers	<a href="http://www.ti.com/clocks">www.ti.com/clocks</a>
Interface	<a href="http://interface.ti.com">interface.ti.com</a>
Logic	<a href="http://logic.ti.com">logic.ti.com</a>
Power Mgmt	<a href="http://power.ti.com">power.ti.com</a>
Microcontrollers	<a href="http://microcontroller.ti.com">microcontroller.ti.com</a>
RFID	<a href="http://www.ti-rfid.com">www.ti-rfid.com</a>
RF/IF and ZigBee® Solutions	<a href="http://www.ti.com/lprf">www.ti.com/lprf</a>

### Applications

Audio	<a href="http://www.ti.com/audio">www.ti.com/audio</a>
Automotive	<a href="http://www.ti.com/automotive">www.ti.com/automotive</a>
Broadband	<a href="http://www.ti.com/broadband">www.ti.com/broadband</a>
Digital Control	<a href="http://www.ti.com/digitalcontrol">www.ti.com/digitalcontrol</a>
Medical	<a href="http://www.ti.com/medical">www.ti.com/medical</a>
Military	<a href="http://www.ti.com/military">www.ti.com/military</a>
Optical Networking	<a href="http://www.ti.com/opticalnetwork">www.ti.com/opticalnetwork</a>
Security	<a href="http://www.ti.com/security">www.ti.com/security</a>
Telephony	<a href="http://www.ti.com/telephony">www.ti.com/telephony</a>
Video & Imaging	<a href="http://www.ti.com/video">www.ti.com/video</a>
Wireless	<a href="http://www.ti.com/wireless">www.ti.com/wireless</a>