

6,77" x 5,905" x 1,496" 172 x 150 x 38 mm

121D
148D

ETRI[®]

DC Axial Fans

查询"148DH1TM11000"供应商

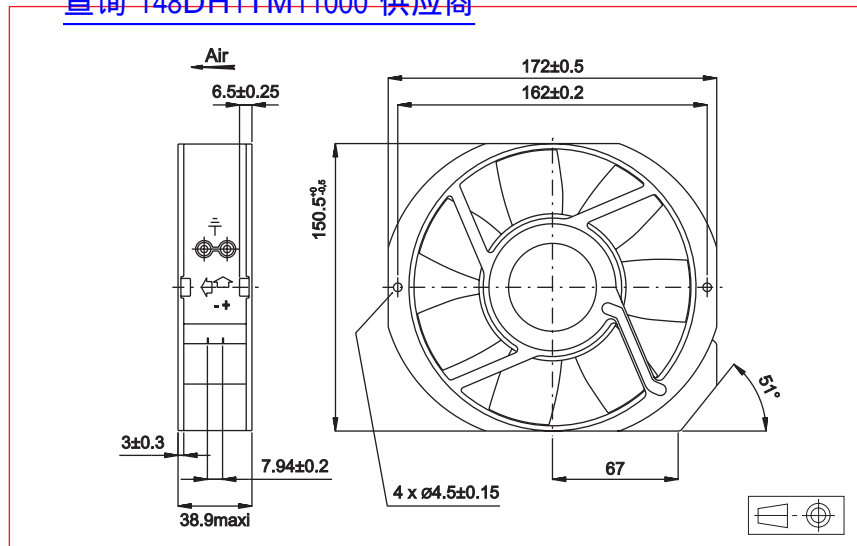

Approvals



Life expectancy

L-10 LIFE AT 40°C:
80 000 hours

Brushless DC Motor

Electrical protection: integrated circuit
Housing material: plastic UL 94 VO
Impeller material: plastic UL 94 VO
Weight: 770 g
Bearing system: ball bearings

Available with:

- Speed sensor
- Alarm
- Flying leads
- IP 54
- UL, CSA and C-UL approvals: 148D models

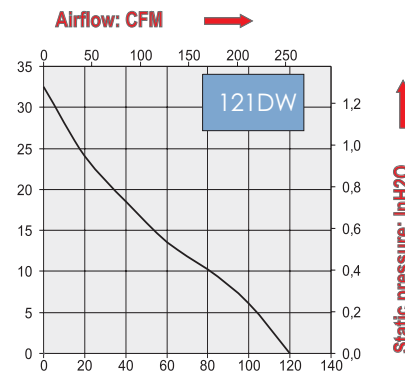
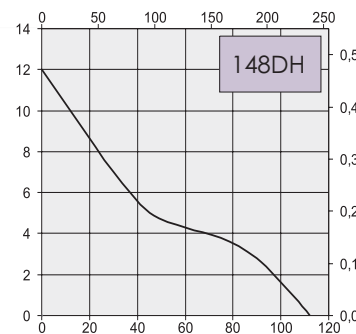
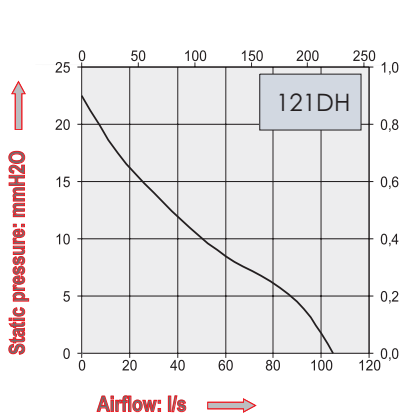

Part Number	Nominal voltage	Airflow	Noise level	Nominal speed	Input Power	Voltage range	Connection type		Operating temperature	
	V	l/s	dB(A)	RPM	W	V	Leads	Terminals	Min.°C	Max.°C
121DH2TM11200	24	105	62	4000	23	(19-28)	X	X	-10	55
148DH1TM11000	12	110	57	3100	13	(9-15)	X	X	-10	70
148DH2TM11000	24	112	58	3100	16,4	(19-28)	X	X	-10	55
148DH4TM11000	48	112	58	3100	16,3	(40-57)	X	X	-10	55
148DH9TM11207	110	112	58	3100	13,4	(76-140)	X	X	-25	70
121DW2TM11200	24	120	66	4650	30	(19-26,5)	X	X	-10	55
121DW9TM11200	28	120	66	4650	30	(19-31)	X	X	-10	55

Additional versions:

Others speeds - salt spray protection
IP54: consult factory

Accessories:

Refer to Accessories leaflet