

PMU for Embedded Camera Module

Check for Samples: [TPS65708](#)

FEATURES

- Two 400mA Step-Down Converters
- Up to 95% Efficiency
- V_{IN} Range for DCDC Converters From 3.6V to 6V
- 2.25MHz Fixed Frequency Operation
- Power Save Mode at Light Load Current
- Output Voltage Accuracy in PWM mode $\pm 1.5\%$
- 100% Duty Cycle for Lowest Dropout
- 180° Out of Phase Operation
- 2 General Purpose 200mA LDOs
- LDOs Optionally Powered From Step-Down Converters
- 7.5mA PWM Dimmable Current Sink
- Available in a 16 Ball WCSP with 0.5mm Pitch

APPLICATIONS

- Monitors
- Laptops
- Handheld Equipment

APPLICATION CIRCUIT

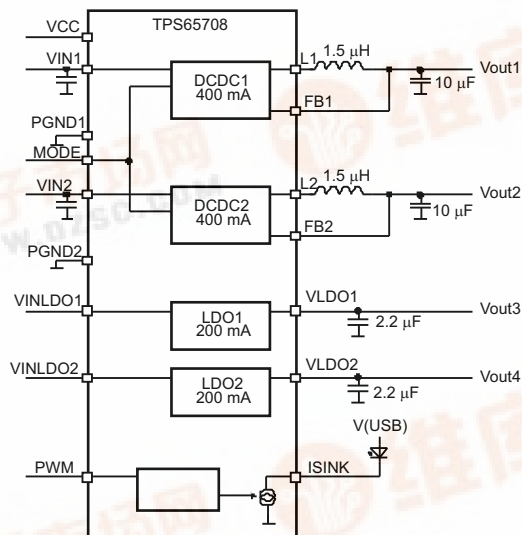

DESCRIPTION

TPS65708 is a power management unit targeted for embedded camera module or other portable low power consumer end equipments. It contains two high efficient step down converters, two low dropout linear regulators and a 7.5mA current sink for driving a LED. The 2.25MHz step-down converter enters a low power mode at light load for maximum efficiency across the widest possible range of load currents. For low noise applications, the devices can be forced into fixed frequency PWM mode using the MODE pin. The device allows the use of small inductors and capacitors to achieve a small solution size. TPS65708 provides an output current of up to 400mA on both DCDC converters and up to 200mA on each of the LDOs. The enable signal to the dc dc converters and LDOs is generated internally by the undervoltage lockout circuit.

The TPS65708 comes in a small 16-ball wafer chip scale package (WCSP) with 0.5mm ball pitch.



Please be aware that an important notice concerning availability, standard warranty, and use in critical applications of Texas Instruments semiconductor products and disclaimers thereto appears at the end of this data sheet.

PRODUCTION DATA information is current as of publication date. Products conform to specifications per the terms of the Texas Instruments standard warranty. Production processing does not necessarily include testing of all parameters.

Copyright © 2010, Texas Instruments Incorporated



TPS65708

SLVSAE1 – OCTOBER 2010
[查询“TPS65708”供应商](#)

www.ti.com



These devices have limited built-in ESD protection. The leads should be shorted together or the device placed in conductive foam during storage or handling to prevent electrostatic damage to the MOS gates.

ORDERING INFORMATION

T _A	PART NO. ⁽¹⁾	SIZE FOR WCSP VERSION	OPTIONS	PACKAGE CODE	PACKAGE	PACKAGE MARKING
-40°C to 85°C	TPS65708	D = 2076 μm ±25 μm E = 2076 μm ±25 μm	VDCDC1 = 3.3V VDCDC2 = 1.8V VLDO1 = 2.8V VLDO2 = 1.2V ISINK(PWM=1) = 7.5mA SEQUENCING : DCDC1, LDO1, DCDC2, LDO2	YZH	WCSP	TPS65708

(1) For the most current package and ordering information, see the Package Option Addendum at the end of this document, or visit the device product folder on ti.com, (<http://www.ti.com>)

ABSOLUTE MAXIMUM RATINGS

over operating free-air temperature range (unless otherwise noted)⁽¹⁾

		VALUE		UNIT
		MIN	MAX	
Voltage range	all pins except A/PGND pins with respect to AGND	-0.3	7	V
	pin VLDO1 and VLDO2 with respect to AGND	-0.3	3.6	V
Current	L1, L2, VLDO1, VLDO2, PGND		700mA	mA
	AGND, ISINK		50mA	mA
	all other pins		3mA	mA
Operating free-air temperature, T _A		-40	85	°C
Maximum junction temperature, T _J			125	°C
Storage temperature, T _{ST}		-65	150	°C

(1) Stresses beyond those listed under *absolute maximum ratings* may cause permanent damage to the device. These are stress ratings only and functional operation of the device at these or any other conditions beyond those indicated under *recommended operating conditions* is not implied. Exposure to absolute-maximum-rated conditions for extended periods may affect device reliability.

THERMAL INFORMATION

THERMAL METRIC ⁽¹⁾		TPS65708	UNITS
		YZH (16 Pins)	
θ _{JA}	Junction-to-ambient thermal resistance	75	°C/W
θ _{JCtop}	Junction-to-case (top) thermal resistance	22	
θ _{JB}	Junction-to-board thermal resistance	26	
ψ _{JT}	Junction-to-top characterization parameter	0.2	
ψ _{JB}	Junction-to-board characterization parameter	24	
θ _{JCbot}	Junction-to-case (bottom) thermal resistance	N/A	

(1) For more information about traditional and new thermal metrics, see the *IC Package Thermal Metrics* application report, [SPRA953](#).

RECOMMENDED OPERATING CONDITIONS

over operating free-air temperature range (unless otherwise noted)

		MIN	NOM	MAX	UNIT
$V_{IN1/2}$	Input voltage range for step-down converter DCDC1 and DCDC2	3.6		6	V
$V_{OUTDCDC1/2}$	Output voltage range for DCDC1 and DCDC2 step-down converter	0.8		3.3	V
$I_{OUTDCDC1}$	DC output current at L1 or L2			400	mA
L	Inductor at L1 or L2 ⁽¹⁾	1	1.5	2.2	μ H
V_{INLDO1}	Input voltage range for LDO1	1.7		6	V
V_{LDO}	Output voltage range for LDO1 and LDO2	0.8		3.3	V
V_{INLDO2}	Input voltage range for LDO2	1.7		6	V
I_{LDO}	Output current at LDO1 or LDO2			200	mA
$C_{INDCDC1/2}$	Input capacitor at V_{IN1} and V_{IN2}	4.7			μ F
$C_{OUTDCDC1/2}$	Output capacitor at V_{OUT1} , V_{OUT2}	4.7	10	22	μ F
$C_{OUTLDO1/2}$	Output capacitor at V_{LDO1} , V_{LDO2}	2.2			μ F
T_A	Operating ambient temperature	-40		85	$^{\circ}$ C
T_J	Operating junction temperature	-40		125	$^{\circ}$ C

(1) To support a typical inductor value of 1.5 μ H, the minimum inductance can go as low as 1.0 μ H. It is not recommended to use a 1 μ H labeled inductor as the inductance will drop significantly below 1 μ H in operation due to initial tolerances and saturation.

ELECTRICAL CHARACTERISTICS

 Unless otherwise noted: $V_{IN1} = V_{IN2} = V_{CC} = 5V$, $L = 1.5\mu H$, $C_{OUTDCDCx} = 10\mu F$, $C_{OUTLDOx} = 2.2\mu F$, $T_A = -40^{\circ}C$ to $85^{\circ}C$

PARAMETER		TEST CONDITIONS	MIN	TYP	MAX	UNIT
SUPPLY CURRENT						
I_Q	Operating quiescent current DCDCx and LDOx	DCDC1, DCDC2, LDO1 and LDO2 enabled, $I_{OUT} = 0$ mA, MODE = 0; (PFM mode) ISINK in standby for PWM = 0		140	200	μ A
		DCDC1, DCDC2, LDO1 and LDO2 enabled, $I_{OUT} = 0$ mA, MODE = 1; (PWM mode) ISINK in standby if PWM = 0; Not including inductor losses		4		mA
		DCDC1, DCDC2, LDO1 and LDO2 enabled, $I_{OUT} = 0$ mA, MODE = 0; (PFM mode); ISINK in standby PWM = 0; During power-up sequencing		170		μ A
I_{SD}	Shutdown Current	DCDCx, LDOx and ISINK disabled; $V_{CC} < 1.8V$		6	15	μ A
DIGITAL PINS (MODE)						
V_{IH}	High Level Input Voltage for MODE		1.2		V_{CC}	V
V_{IL}	Low Level Input Voltage for MODE		0		0.4	V
I_{kg}	Input Leakage Current	MODE tied to GND or V_{IN1} / V_{IN2}		0.01	0.1	μ A
UNDERVOLTAGE LOCKOUT (UVLO), SENSED AT PIN VCC						
UVLO	Internal undervoltage lockout threshold	V_{CC} , V_{IN1} , V_{IN2} rising	3.5	3.6	3.7	V
	Internal undervoltage lockout threshold hysteresis	V_{CC} , V_{IN1} , V_{IN2} falling		130		mV
STEP-DOWN CONVERTERS						
V_{IN1}	Input voltage for DCDC1		3.5		6	V
V_{IN2}	Input voltage for DCDC2		3.5		6	V
POWER SWITCH						
$R_{DS(on)}$	High side MOSFET on-resistance	$V_{IN1} / V_{IN2} = 3.6V$		250	400	m Ω
	Low side MOSFET on-resistance	$V_{IN1} / V_{IN2} = 3.6V$		150	300	m Ω
I_{LIMF}	Forward current limit	$3.6V \leq V_{IN1} / V_{IN2} \leq 6V$	650	820	1050	mA
I_O	DC output current	$V_{IN1} / V_{IN2} > 3.5V$, $L = 1.5\mu H$			400	mA

TPS65708

SLVSAE1 – OCTOBER 2010
[查询“TPS65708”供应商](#)

www.ti.com

ELECTRICAL CHARACTERISTICS (continued)

Unless otherwise noted: VIN1 = VIN2 = VCC = 5V, L = 1.5µH, C_{OUTDCDCx} = 10µF, C_{OUTLDOx} = 2.2µF, T_A = -40°C to 85°C

PARAMETER		TEST CONDITIONS	MIN	TYP	MAX	UNIT
OSCILLATOR						
f _{SW}	Oscillator frequency		2.03	2.25	2.48	MHz
OUTPUT						
V _{OUT1}	DCDC1 default output voltage	VIN1 ≥ 3.6V		3.3		V
V _{OUT2}	DCDC2 default output voltage	VIN2 ≥ 3.6V		1.8		V
I _{FB}	FB pin input current	dcdc converter input voltage below undervoltage lockout threshold			0.1	µA
R _{FB}	FB pin input resistance due to internal voltage divider	dcdc converter input voltage above undervoltage lockout threshold; V _{OUT} = 3.3V		990		kΩ
R _{FB}	FB pin input resistance due to internal voltage divider	dcdc converter input voltage above undervoltage lockout threshold; V _{OUT} = 1.8V		585		kΩ
V _{OUT}	DC output voltage accuracy ⁽¹⁾	VIN1 and VIN2 = 3.6V to 6V, +1% voltage positioning active; PFM operation, 0 mA < I _{OUT} < I _{OUTmax}		1.25%	3%	
	DC output voltage accuracy	VIN1 / VIN2 = 3.3V to 6V, PWM operation, 0 mA < I _{OUT} < I _{OUTmax}	-1.5%		1.5%	
	DC output voltage load regulation	PWM operation		0.5		%/A
t _{Start}	Start-up time	Time from UVLO is exceeded (Vin > 3.6V) to Start switching		200		µs
t _{Ramp}	V _{OUT} ramp time	Time to ramp from 5% to 95% of V _{OUT}		250		µs
R _{DIS}	Internal discharge resistor at L1 and L2	DCDCx disabled; 1V < VIN1/2 < 3.6V	300	400	550	Ω
THERMAL PROTECTION SEPARATELY FOR DCDC1, DCDC2 and LDO1						
T _{SD}	Thermal shutdown	Increasing junction temperature		150		°C
	Thermal shutdown hysteresis	Decreasing junction temperature		30		°C
VLDO1, VLDO2 LOW DROPOUT REGULATOR						
V _{INLDO}	Input voltage range for LDO1 and LDO2		1.7		6	V
V _{LDO1}	LDO1 Default Output Voltage (1)			2.8		V
V _{LDO2}	LDO2 Default Output Voltage			1.2		V
I _O	Output current for LDO1 and LDO2				200	mA
I _{SC}	LDO1 and LDO2 short circuit current limit	V _{LDOx} = GND	260	360	550	mA
	Dropout voltage at LDOx	I _O = 200mA; VINLDOx = 3.3V			200	mV
	Dropout voltage at LDOx	I _O = 200mA; VINLDOx = 1.8V			300	mV
	Output voltage accuracy for LDO1 and LDO2	I _O = 200mA	-2%		2%	
	Line regulation for LDO1 and LDO2	VINLDO = VLDO + 0.5V (min 1.7V) to 6V, I _O = 50mA	-1%		1%	
	Load regulation for LDO1 and LDO2	I _O = mA to 200mA	-1.5		1	%
PSRR	Power Supply Rejection Ratio	f = 10kHz, C _{OUT} ≥ 2.2µF VINLDOx = 5V, V _{OUT} = 2.8V, I _{OUT} = 100mA		50		dB
V _n	Output noise voltage	V _{OUT} = 2.8V, BW = 10Hz to 100kHz		160		µV RMS
t _{Ramp}	V _{OUT} ramp time	Internal soft-start when LDO is enabled; Time to ramp from 5% to 95% of V _{OUT}		250		µs
R _{DIS}	Internal discharge resistor at VLDO1 and VLDO2	V _{IN} < UVLO	200	400	550	Ω

(1) VINLDO > 2.8V

ELECTRICAL CHARACTERISTICS (continued)

 Unless otherwise noted: VIN1 = VIN2 = VCC = 5V, L = 1.5μH, C_{OUTDCDCx} = 10μF, C_{OUTLDOx} = 2.2μF, T_A = –40°C to 85°C

PARAMETER		TEST CONDITIONS	MIN	TYP	MAX	UNIT
LED CURRENT SINK						
I _{LED}	Isink Current (LED current for 100% duty cycle)	Set internally by EEPROM to 7.5mA; available current range from 7.5mA to 30mA; contact factory about default settings other than 7.5mA		7.5		mA
	Minimum voltage drop from ISINK to AGND needed for proper regulation	at 7.5mA ≤ ISINK ≤ 20mA			0.4	V
	Minimum voltage drop from ISINK to AGND needed for proper regulation	at 20mA < ISINK ≤ 30mA			0.55	V
	ISINK accuracy	ISINK ≥ 10mA	–5%		5%	
	ISINK accuracy	7.5mA ≤ ISINK < 10mA	–10%		10%	
	PWM duty cycle		5%		100%	
	PWM frequency				50	kHz
V _{IH}	High Level Input Voltage for PWM pin	ISINK is enabled	1.2		V _{CC}	V
V _{IL}	Low Level Input Voltage for PWM pin	ISINK is high resistive	0		0.4	V
I _{lkg}	Input Leakage Current on PWM pin			0.01	0.1	μA
	ISINK rise / fall time	V _(ISINK) ≥ 0.4V for 7.5 mA ≤ ISINK ≤ 20mA; or V _(ISINK) > 0.6V for 20mA < ISINK ≤ 30mA		500		ns
	ISINK rise / fall time	V _(ISINK) ≤ 0.6V; 20mA < ISINK ≤ 30 mA		700		ns

PIN ASSIGNMENT

YZH PACKAGE (BOTTOM VIEW)

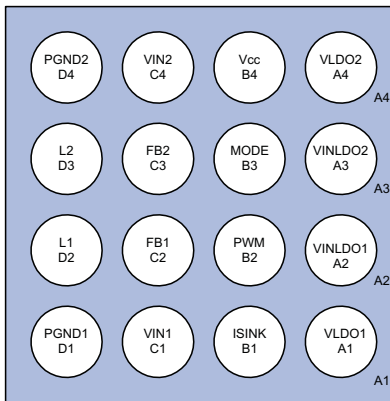

Pin Functions for Chip Scale Version (YZH Package)

PIN		I/O	DESCRIPTION
NAME	NO.		
VCC	B41	I	Supply Input for internal reference, has to be connected to VIN1 and VIN2
PGND1	D1		Power ground
PGND2	D4		Power ground
VIN1	C12	I	Input voltage pin for buck converter ⁽¹⁾
VIN2	C42	I	Input voltage pin for buck converter ⁽²⁾
L1	D2	O	Switch output from buck converter ⁽¹⁾
FB1	C2	I	Feedback input from buck converter ⁽¹⁾
L2	D3	O	Switch output from buck converter ⁽²⁾
FB2	C3	I	Feedback input from buck converter ⁽²⁾
VLDO1	A1	O	Output voltage from LDO1
VLDO2	A4	O	Output voltage from LDO2
VINLDO1	A2	I	Input voltage pin for LDO1
VINLDO2	A3	I	Input voltage pin for LDO2
MODE	B3	I	Set low to enable Power Save Mode. Pulling this PIN to high forces the device to operate in PWM mode over the whole load range.
ISINK	B1	O	Open drain current sink; connect to the cathode of a LED
PWM	B2	I	Input for LED PWM dimming

(1) VCC has to be the highest input voltage for the device to operate correctly.

(2) VIN1/VIN2 must be connected to VCC

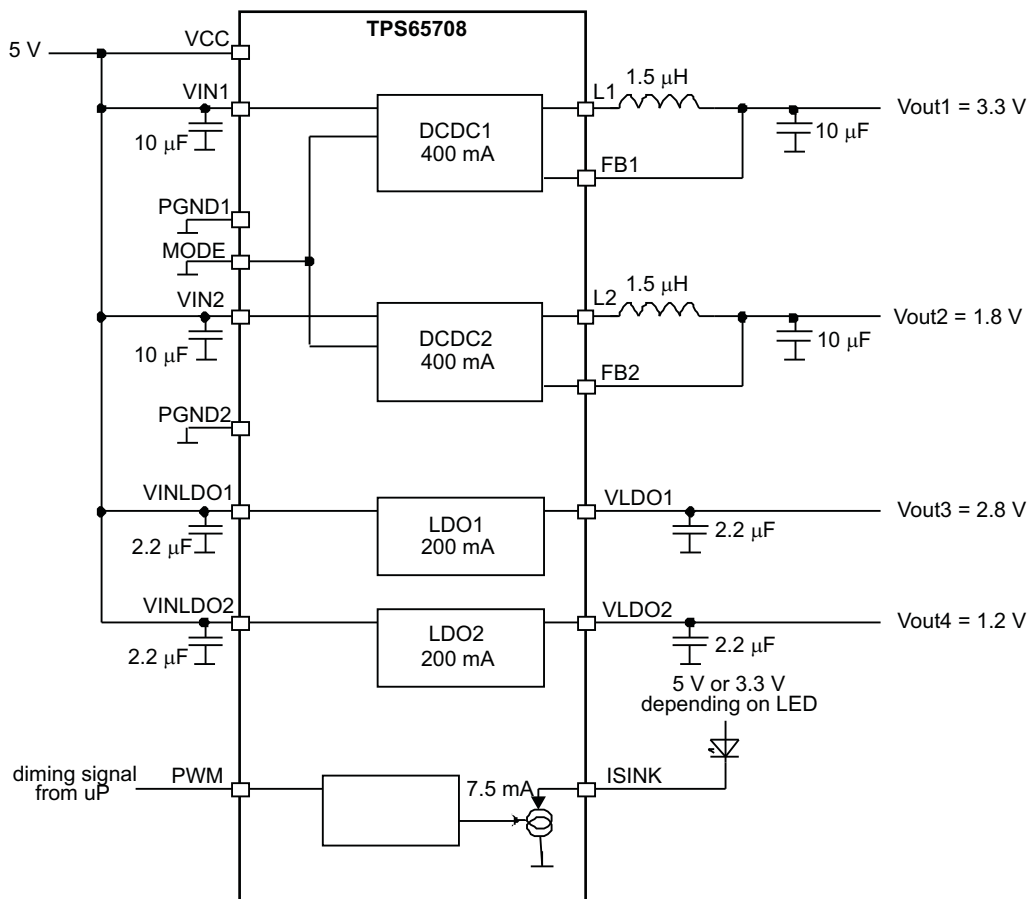
FUNCTIONAL BLOCK DIAGRAM

PARAMETER MEASUREMENT INFORMATION
SETUP

The graphs below were taken using the TPS65708EVM with the passive components as listed:

$L(V_{out1}) = L(V_{out2}) = \text{BRC1608T1R5M} (1.5\mu\text{H})$

$C(V_{out1}) = C(V_{out2}) = \text{GRM188R60J106} (10\mu\text{F} / 6.3\text{V})$

$C(LDO1) = C(LDO2) = \text{GRM185R60J225} (2.2\mu\text{F} / 6.3\text{V})$

$C(VIN1) = C(VIN2) = \text{GRM188R60J106} (10\mu\text{F} / 6.3\text{V})$

$C(VINLDO1) = C(VINLDO2) = \text{GRM185R60J225} (2.2\mu\text{F} / 6.3\text{V})$

$V_{CC} = VIN1 = VIN2 = VINLDO1 = VINLDO2$ unless otherwise noted

TYPICAL CHARACTERISTICS

TABLE OF GRAPHS

			FIGURE
η	Efficiency DCDC ($V_O = 3.3V$)	vs Load current / PFM mode;	Figure 1
η	Efficiency DCDC ($V_O = 3.3V$)	vs Load current / PWM mode	Figure 2
η	Efficiency DCDC ($V_O = 1.2V$)	vs Load current / PFM mode	Figure 3
η	Efficiency DCDC ($V_O = 1.2V$)	vs Load current / PWM mode	Figure 4
	Line transient response DCDC (PWM)	Scope plot for a 3.6V to 5V to 3.6V input voltage change	Figure 5
	Line transient response DCDC (PFM)	Scope plot for a 3.6V to 5V to 3.6V input voltage change	Figure 6
	Line transient response LDO	Scope plot for a 3.6V to 5V to 3.6V input voltage change	Figure 7
	Load transient response DCDC (PFM)	Scope plot for a 10% to 90% load step (40mA to 360mA)	Figure 8
	Load transient response DCDC (PWM)	Scope plot for a 10% to 90% load step (40mA to 360mA)	Figure 9
	Load transient response LDO	Scope plot for a 10% to 90% load step (20mA to 180mA)	Figure 10
	Startup timing DCDC1, DCDC2, LDO1 and LDO2	Scope plot of startup; "R1" = supply voltage is applied	Figure 11
	LDO POWER SUPPLY REJECTION RATIO (PSRR)	Scope plot	Figure 12

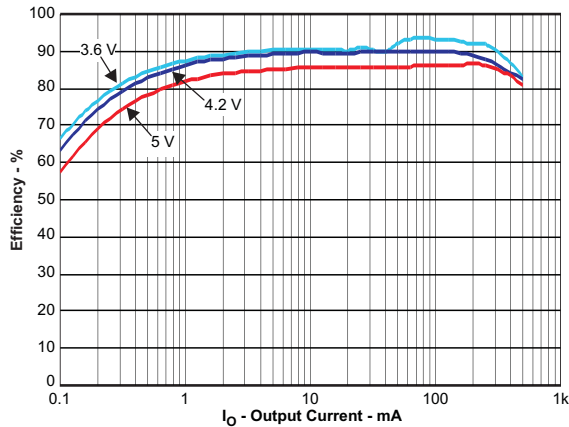

Figure 1. EFFICIENCY DCDC ($V_O = 3.3 V$) vs LOAD CURRENT / PFM MODE; for $V_{IN} = 3.6V$ to $5V$

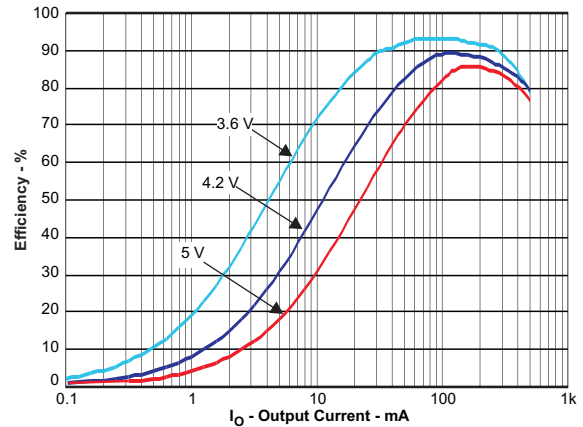

Figure 2. EFFICIENCY DCDC ($V_O = 3.3 V$) vs LOAD CURRENT / PWM MODE; for $V_{IN} = 3.6V$ to $5V$

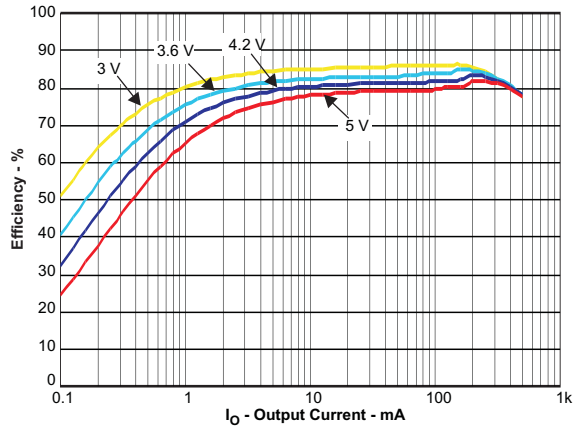

Figure 3. EFFICIENCY DCDC ($V_O = 1.2\text{ V}$) vs LOAD CURRENT / PFM MODE; for $V_{IN} = 3.0\text{ V}$ to 5 V

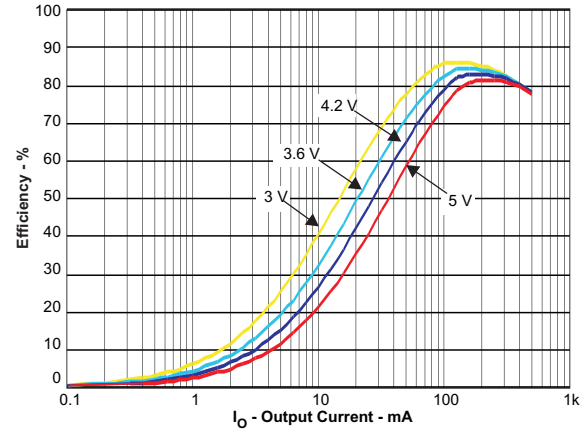

Figure 4. EFFICIENCY DCDC ($V_O = 1.2\text{ V}$) vs LOAD CURRENT / PWM MODE; for $V_{IN} = 3.0\text{ V}$ to 5 V

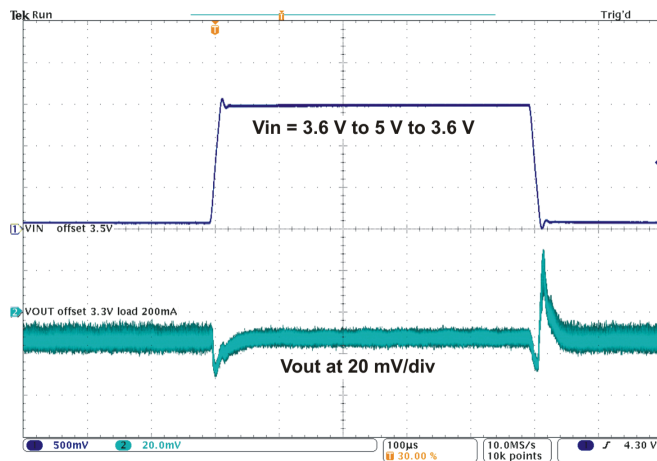

Figure 5. LINE TRANSIENT RESPONSE DCDC (PWM)

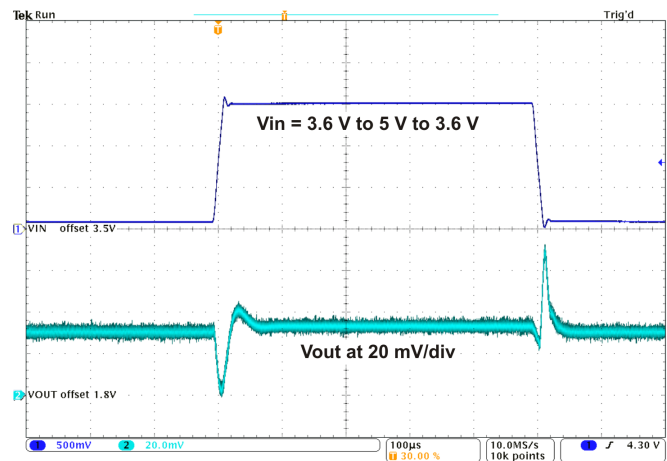

Figure 6. LINE TRANSIENT RESPONSE DCDC (PFM)

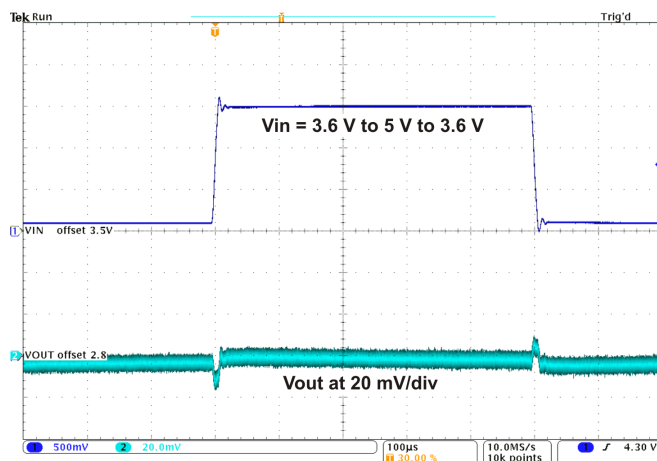

Figure 7. LINE TRANSIENT RESPONSE LDO

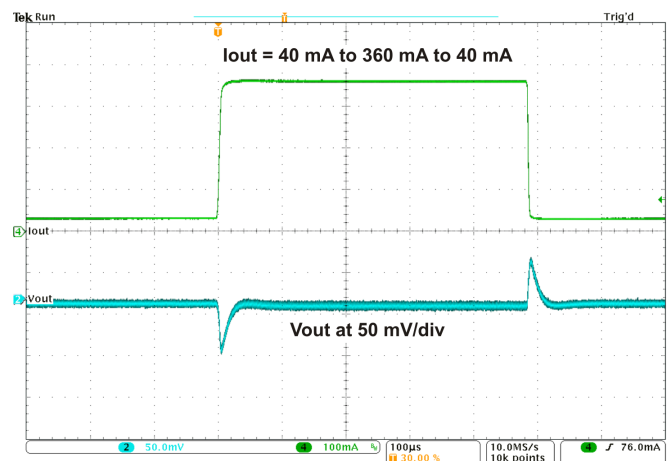

Figure 8. LOAD TRANSIENT RESPONSE DCDC (PFM)

TPS65708

SLVSAE11 - OCTOBER 2010
[查询"TPS65708"供应商](#)

www.ti.com

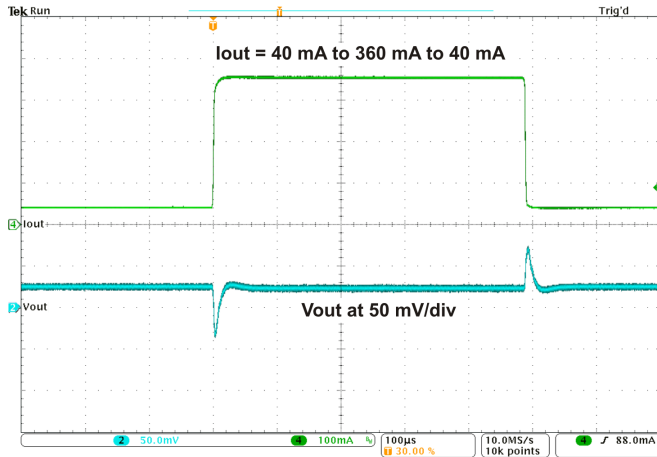

Figure 9. LOAD TRANSIENT RESPONSE DCDC (PWM)

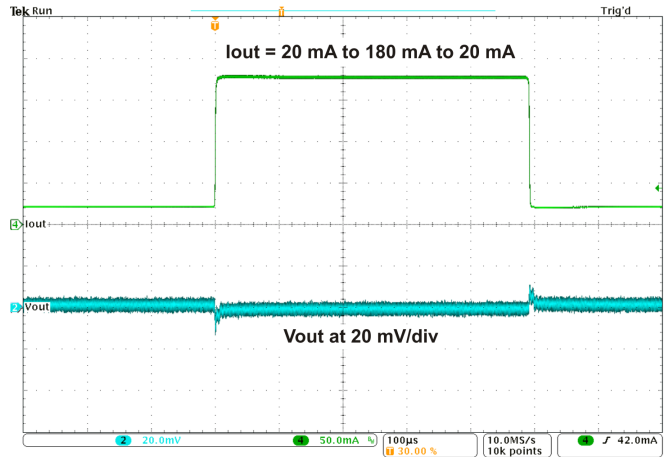

Figure 10. LOAD TRANSIENT RESPONSE LDO

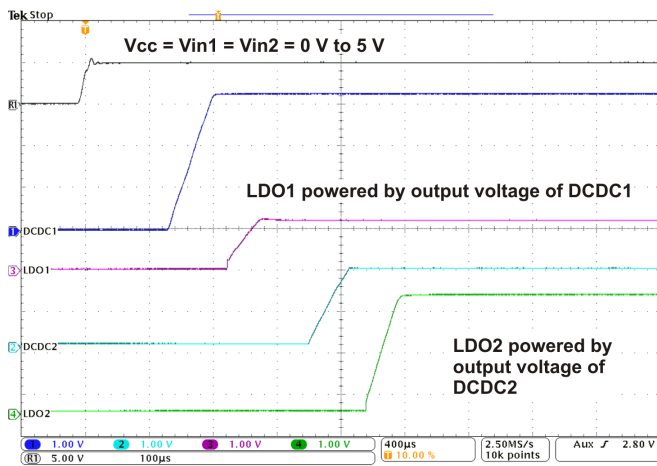

Figure 11. STARTUP SEQUENCING

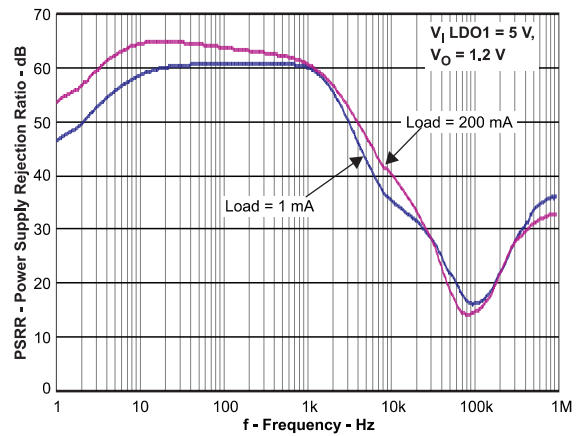

Figure 12. LDO POWER SUPPLY REJECTION RATIO (PSRR)

DETAILED DESCRIPTION

DCDC CONVERTERS

The TPS65708 step down converters operate with typically 2.25MHz fixed frequency pulse width modulation (PWM) at moderate to heavy load currents. With MODE pin set to low, at light load currents the converter can automatically enter Power Save Mode and operates then in PFM mode.

During PWM operation the converter use a unique fast response voltage mode control scheme with input voltage feed-forward to achieve good line and load regulation allowing the use of small ceramic input and output capacitors. At the beginning of each clock cycle initiated by the clock signal, the High Side MOSFET switch is turned on. The current flows now from the input capacitor via the High Side MOSFET switch through the inductor to the output capacitor and load. During this phase, the current ramps up until the PWM comparator trips and the control logic will turn off the switch. The current limit comparator will also turn off the switch in case the current limit of the High Side MOSFET switch is exceeded. After an off time preventing shoot through current, the Low Side MOSFET rectifier is turned on and the inductor current will ramp down. The current flows now from the inductor to the output capacitor and to the load. It returns back to the inductor through the Low Side MOSFET rectifier.

The next cycle is initiated by the clock signal again turning off the Low Side MOSFET rectifier and turning on the on the High Side MOSFET switch. A 180° phase shift between DCDC1 and DCDC2 decreases the input RMS current and synchronizes the operation of the two dc/dc converts. The FB pin must directly be connected to the output voltage of the DCDC converter and no external resistor network must be connected. As the Feedback input serves as the power input to the LOD, the external connection should be as short and as thick as possible to keep the voltage drop as small as possible.

POWER SAVE MODE

The Power Save Mode is enabled with Mode Pin set to low. If the load current decreases, the converter will enter Power Save Mode operation automatically. During Power Save Mode the converter skips switching and operates with reduced frequency in PFM mode with a minimum quiescent current to maintain high efficiency. The converter positions the output voltage typically +1% above the nominal output voltage. This voltage positioning feature minimizes voltage drops caused by a sudden load step. The transition from PWM mode to PFM mode occurs once the inductor current in the Low Side MOSFET switch becomes zero, which indicates discontinuous conduction mode. During the Power Save Mode the output voltage is monitored with a PFM comparator. As the output voltage falls below the PFM comparator threshold of VOUT nominal +1%, the device starts a PFM current pulse. The High Side MOSFET switch will turn on, and the inductor current ramps up. After the On-time expires, the switch is turned off and the Low Side MOSFET switch is turned on until the inductor current becomes zero. The converter effectively delivers a current to the output capacitor and the load. If the load is below the delivered current, the output voltage will rise. If the output voltage is equal or higher than the PFM comparator threshold, the device stops switching and enters a sleep mode with typical 25µA current consumption.

If the output voltage is still below the PFM comparator threshold, a sequence of further PFM current pulses are generated until the PFM comparator threshold is reached. The converter starts switching again once the output voltage drops below the PFM comparator threshold. With a fast single threshold comparator, the output voltage ripple during PFM mode operation can be kept small. The PFM Pulse is time controlled, which allows to modify the charge transferred to the output capacitor by the value of the inductor. The resulting PFM output voltage ripple and PFM frequency depend in first order on the size of the output capacitor and the inductor value. Increasing output capacitor values and inductor values will minimize the output ripple. The PFM frequency decreases with smaller inductor values and increases with larger values. The PFM mode is left and PWM mode is entered in case the output current can no longer be supported in PFM mode. The Power Save Mode can be disabled by setting Mode pin to high. The converter will then operate in fixed frequency PWM mode.

DYNAMIC VOLTAGE POSITIONING

This feature reduces the voltage under/overshoots at load steps from light to heavy load and heavy to light. It is active in Power Save Mode and regulates the output voltage 1% higher than the nominal value. This provides more headroom for both the voltage drop at a load step, and the voltage increase at a load throw-off.

TPS65708

SLVSAE11 - OCTOBER 2010
[查询TPS65708 供应商](#)

www.ti.com

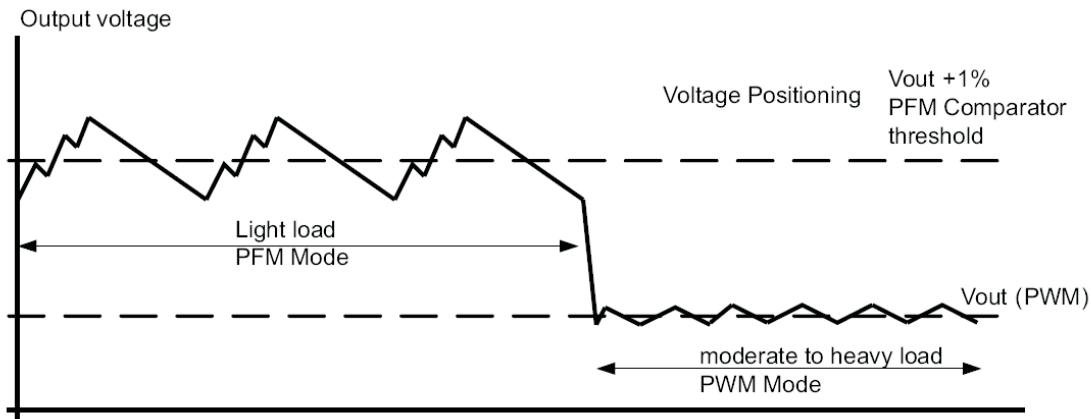

SOFT START

The step-down converter in TPS65708 has an internal soft start circuit that controls the ramp up of the output voltage. The output voltage ramps up from 5% to 95% of its nominal value within typical 250µs. This limits the inrush current in the converter during ramp up and prevents possible input voltage drops when a battery or high impedance power source is used.

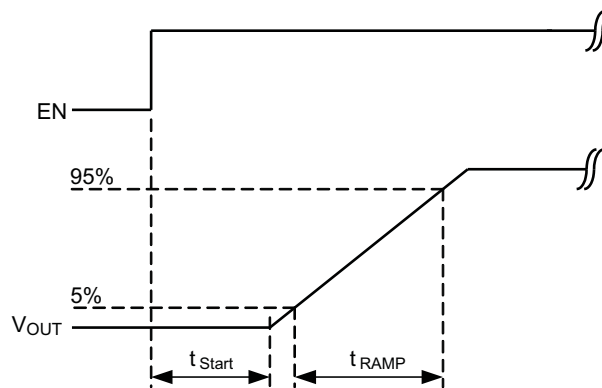

Figure 13. Soft Start

100% DUTY CYCLE LOW DROPOUT OPERATION

The device starts to enter 100% duty cycle mode once the input voltage comes close to the nominal output voltage. In order to maintain the output voltage, the High Side MOSFET switch is turned on 100% for one or more cycles. With further decreasing VIN the High Side MOSFET switch is turned on completely. In this case, the converter offers a low input-to-output voltage difference. This is particularly useful in battery-powered applications to achieve longest operation time by taking full advantage of the whole battery voltage range. The minimum input voltage to maintain regulation depends on the load current and output voltage, and can be calculated as:

$$V_{INmin} = V_{Omax} + I_{Omax} (R_{DS(on)max} + R_L)$$

With

I_{Omax} = maximum output current plus inductor ripple current

$R_{DS(on)max}$ = maximum high side switch $R_{DS(on)}$.

R_L = DC resistance of the inductor

V_{Omax} = nominal output voltage plus maximum output voltage tolerance

180° OUT-OF-PHASE OPERATION

In PWM Mode, the converters operate with a 180° turn-on phase shift of the PMOS (high side) transistors. This prevents the high-side switches of both converters from being turned on simultaneously, and therefore smooths the input current. This feature reduces the surge current drawn from the supply.

UNDER VOLTAGE LOCKOUT / ENABLE for DCDC1, DCDC2, LDO1 and LDO2

The under voltage lockout circuit prevents the device from malfunctioning at low input voltages and from excessive discharge of the battery. It disables the dc/dc converters and LDOs at too low input voltages.

As TPS65708 does not have enable pins for the dc/dc converters and LDOs, the internal under voltage lockout not only serves as a protection circuit but also as an enable circuitry. The supply voltage to TPS65708 is internally sensed at pin V_{CC} . When the voltage at V_{CC} exceeds 3.6V, the internal enable signals to the dc/dc converter and LDOs are set HIGH to start-up the outputs in the pre-defined sequence. When the supply voltage drops below 3.6V, the dc/dc converters and LDOs are disabled again and the discharge circuitry is enabled to make sure the voltage at the output capacitor ramps down quickly. Disabling the dc/dc converter or LDO, forces the device into shutdown, with a shutdown quiescent current as defined in the electrical characteristics. In this mode, the power FETs are turned-off and the entire internal control circuitry is switched-off.

OUTPUT VOLTAGE DISCHARGE

The dc/dc converters and LDOs contain an output capacitor discharge feature which makes sure that the capacitor is discharged when the supply voltage drops below the undervoltage lockout threshold. The discharge has a built in delay function, so the output discharge is active for a couple of 100ms after the V_{CC} voltage dropped below its undervoltage lockout threshold. This will make sure that the cap is discharged even the supply voltage dropped below 2.1V. The discharge function is also enabled when voltage is applied at V_{CC} starting at about 2.1V until the voltage exceeded the undervoltage lockout threshold that enables the power-up sequencing.

POWER-UP SEQUENCING

There are 3 different power-up sequencing options available. The options are factory set and can not be changed by the user. Contact TI if an option different from the default is needed.

1. DCDC1, DCDC2, LDO1 and LDO2 are turning on at the same time.
2. DCDC1 first, when power good, LDO1 is enabled, when power good, DCDC2 is enabled when power good, LDO2 is enabled
3. DCDC2 first, when power good, LDO2 is enabled, when power good, DCDC1 is enabled when power good, LDO1 is enabled

TPS65708 is set to option 2 such that DCDC1 starts first followed by LDO1, DCDC2 and LDO2. See also the timing diagram under the table of graphs.

SHORT-CIRCUIT PROTECTION

All outputs are short circuit protected with a maximum output current as defined in the electrical specifications.

THERMAL SHUTDOWN

As soon as the junction temperature, T_J , exceeds typically 150°C for the dc/dc converters or LDOs, the device goes into thermal shutdown. In this case, the low side and high side MOSFETs for the dc/dc converters as well as the LDOs are turned-off. The device continues its operation and powers up the dc/dc converters and LDOs with the pre-defined sequencing when the junction temperature falls below the thermal shutdown hysteresis again. During thermal shutdown also the LED driver is disabled.

LDOs

The low dropout voltage regulators are designed to operate well with low value ceramic input and output capacitors. They operate with input voltages down to 1.7V. Both LDOs offer a maximum dropout voltage of 300mV at rated output current. The LDOs support a current limit feature.

TPS65708

SLVSAE11 – OCTOBER 2010
[查询 TPS65708 供应商](#)

www.ti.com

LED DRIVER

TPS65708 contains a LED driver for a current of up to 30mA. ISINK is an open drain current sink that regulates a current in an LED. The anode of the LED needs to be tied to a positive supply voltage e.g., V_{CC} or the output voltage of one of the dc/dc converters in TPS65708, depending on the forward voltage of the LED. The cathode of the LED is connected to ISINK which sets a constant current to GND. ISINK is regulated internally based on the default current set internally. In addition, the LED current can be PWM dimmed by a signal applied to pin PWM. If pin PWM is pulled LOW, the LED driver is disabled and its output ISINK is high resistive. If PWM is HIGH, the current sink regulates to the current defined by EEPROM (TI factory set in two ranges. 7.5mA to 15mA with 0.5mA resolution and 15mA to 30mA in 1mA resolution). The maximum PWM frequency is 50kHz with a duty cycle range of 5% to 100%. TPS65708 is set to 7.5mA as a default. Contact TI about different default settings.

APPLICATION INFORMATION

OUTPUT FILTER DESIGN (INDUCTOR AND OUTPUT CAPACITOR)

Inductor selection

The converter operates typically with a 1.5 μ H or 2.2 μ H output inductor. The selected inductor has to be rated for its dc resistance and saturation current. The DC resistance of the inductance will influence directly the efficiency of the converter. Therefore an inductor with lowest dc resistance should be selected for highest efficiency.

[Equation 1](#) calculates the maximum inductor current under static load conditions. The saturation current of the inductor should be rated higher than the maximum inductor current as calculated with [Equation 1](#). This is recommended because during heavy load transient the inductor current will rise above the calculated value.

$$\Delta I_L = V_{out} \times \frac{1 - \frac{V_{out}}{V_{in}}}{L \times f} \qquad I_{Lmax} = I_{outmax} + \frac{\Delta I_L}{2} \qquad (1)$$

With:

- f = Switching Frequency (2.25 MHz typical)
- L = Inductor Value
- ΔI_L = Peak-to-Peak inductor ripple current
- I_{Lmax} = Maximum Inductor current

The highest inductor current will occur at maximum V_{in} .

Open core inductors have a soft saturation characteristic and they can usually handle higher inductor currents versus a comparable shielded inductor.

A more conservative approach is to select the inductor current rating just for the maximum switch current of the corresponding converter. It must be considered, that the core material from inductor to inductor differs and will have an impact on the efficiency especially at high switching frequencies.

Note that the step down converter has internal loop compensation. The internal loop compensation is designed to work with an output filter corner frequency calculated as follows:

$$f_c = \frac{1}{2\pi\sqrt{L \times C_{out}}} \text{ with } L = 1.5 \mu\text{H}, C_{out} = 10 \mu\text{F} \qquad (2)$$

This leads to the fact the selection of external L-C filter has to be coped with the above equation. As a general rule the product of $L \times C_{OUT}$ should be constant while selecting smaller inductor or increasing output capacitor value.

[Table 1](#) and the typical applications for possible inductors.

Table 1. Tested Inductors

Inductor type	Inductor Value	Supplier
BRC1608	1.5 µH	Taiyo Yuden
MLP2012	2.2 µH	TDK
MIPSA2520	2.2 µH	FDK
GLCR1608T1R5M-HC	1.5 µH	TDK
LQM21P	2.2 µH	Murata

Output Capacitor Selection

The advanced Fast Response voltage mode control scheme of the step-down converter allows the use of small ceramic capacitors with a typical value of 10µF, without having large output voltage under and overshoots during heavy load transients. Ceramic capacitors having low ESR values result in lowest output voltage ripple and are therefore recommended. For an inductor value of 1.5µH or 2.2µH, an output capacitor with 10µF can be used. See the recommended components.

If ceramic output capacitors are used, the capacitor RMS ripple current rating will always meet the application requirements. Just for completeness the RMS ripple current is calculated as:

$$I_{\text{RMS}C_{\text{out}}} = V_{\text{out}} \times \frac{1 - \frac{V_{\text{out}}}{V_{\text{in}}}}{L \times f} \times \frac{1}{2 \times \sqrt{3}} \quad (3)$$

At nominal load currents, the inductive converters operate in PWM mode and the overall output voltage ripple is the sum of the voltage spike caused by the output capacitor ESR plus the voltage ripple caused by charging and discharging the output capacitor:

$$\Delta V_{\text{out}} = V_{\text{out}} \times \frac{1 - \frac{V_{\text{out}}}{V_{\text{in}}}}{L \times f} \times \left(\frac{1}{8 \times C_{\text{out}} \times f} + \text{ESR} \right) \quad (4)$$

Where the highest output voltage ripple occurs at the highest input voltage V_{in} .

At light load currents, the converter operates in Power Save Mode and the output voltage ripple is dependent on the output capacitor value. The output voltage ripple is set by the internal comparator delay and the external capacitor. The typical output voltage ripple is less than 1% of the nominal output voltage.

Input Capacitor Selection

Because of the nature of the buck converter having a pulsating input current, a low ESR input capacitor is required for best input voltage filtering and minimizing the interference with other circuits caused by high input voltage spikes. The converters need a ceramic input capacitor of 10µF. The input capacitor can be increased without any limit for better input voltage filtering.

Table 2. Tested Capacitors

Type	value	Voltage rating	Size	Supplier	Material
GRM155R60G475ME47D	4.7 µF	4 V	0402	Murata	Ceramic X5R
GRM155R60J225ME15D	2.2 µF	6.3 V	0402	Murata	Ceramic X5R
GRM185R60J225	2.2 µF	6.3 V	0603	Murata	Ceramic X5R
GRM188R60J475K	4.7 µF	6.3 V	0603	Murata	Ceramic X5R
GRM188R60J106ME47D	10 µF	6.3 V	0603	Murata	Ceramic X5R

TPS65708

SLVSAE1 - OCTOBER 2010
[查询TPS65708 供应商](#)

www.ti.com

APPLICATION CIRCUITS

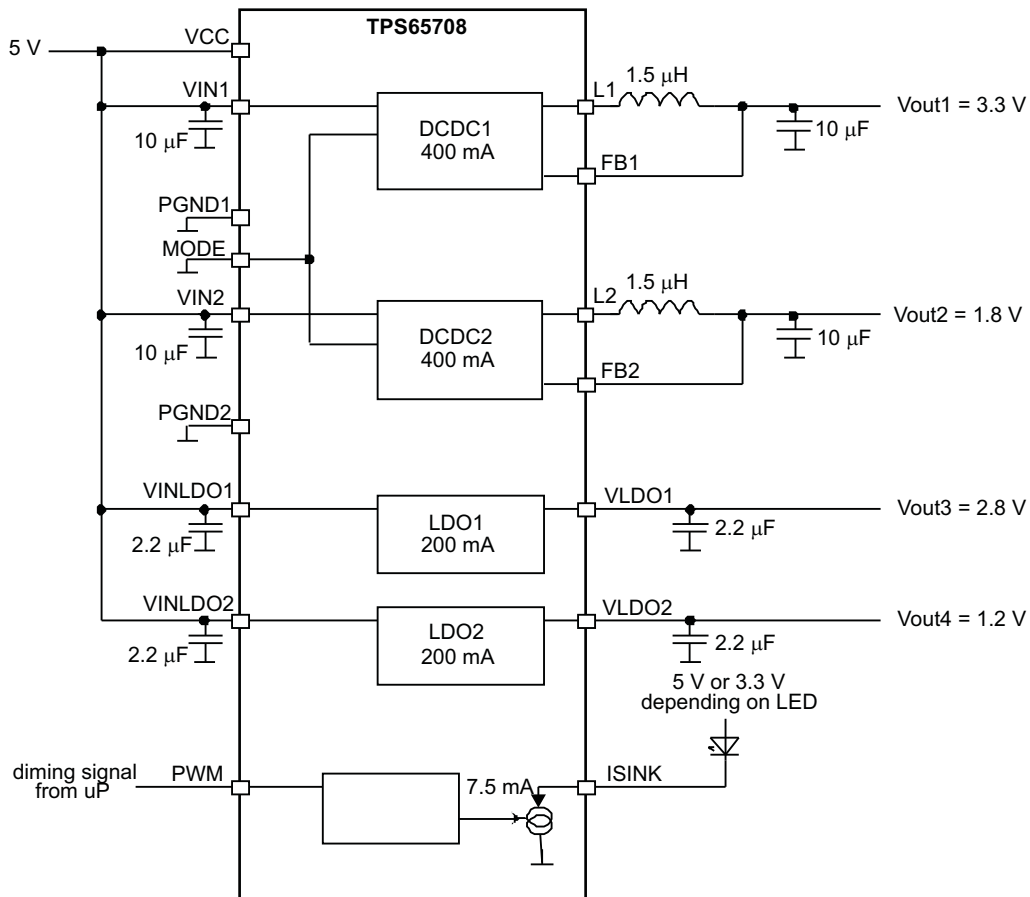

Figure 14. Powering All Rails From the Input Supply of 5V

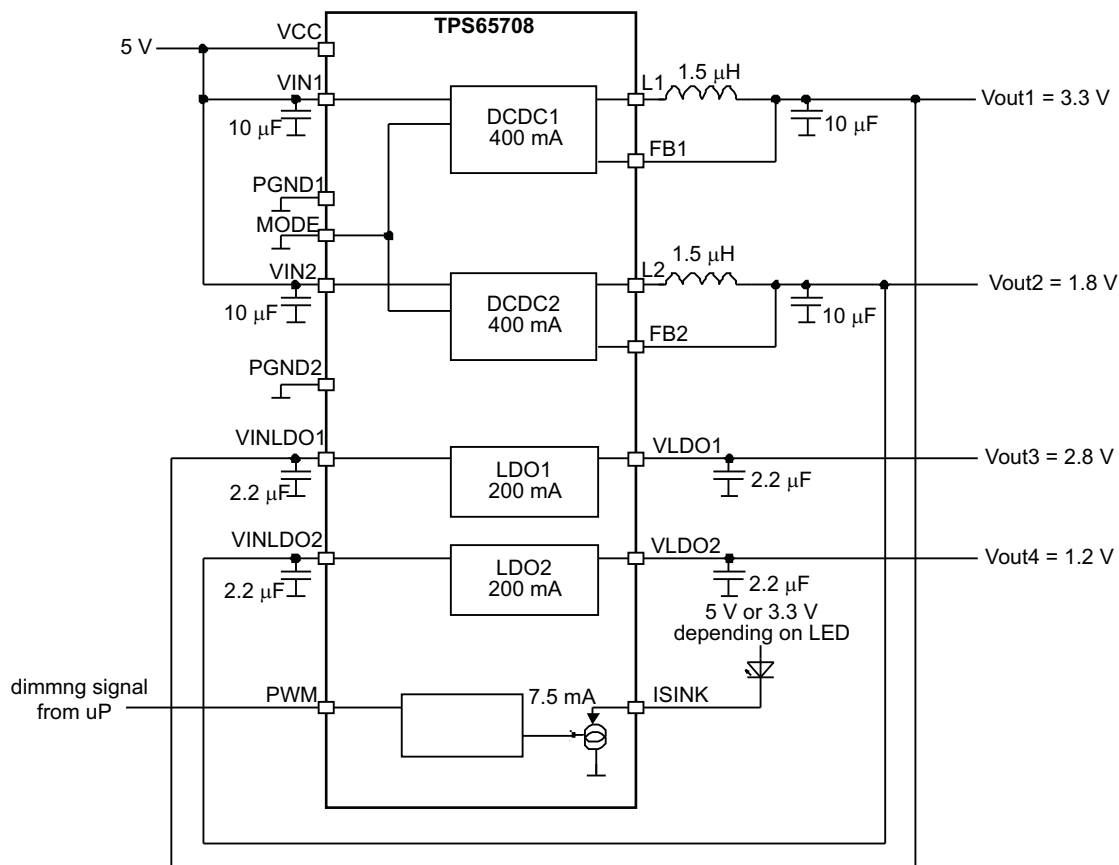

Figure 15. Powering the LDOs From the Output of the DCDC Converters to Improve Efficiency



www.ti.com

PACKAG

PACKAGING INFORMATION

Orderable Device	Status ⁽¹⁾	Package Type	Package Drawing	Pins	Package Qty	Eco Plan ⁽²⁾	Lead/Ball Finish	MSL Peak Temp
TPS65708YZHR	ACTIVE	DSBGA	YZH	16	3000	Green (RoHS & no Sb/Br)	SNAGCU	Level-1-2600
TPS65708YZHT	ACTIVE	DSBGA	YZH	16	250	Green (RoHS & no Sb/Br)	SNAGCU	Level-1-2600

⁽¹⁾ The marketing status values are defined as follows:

ACTIVE: Product device recommended for new designs.

LIFEBUY: TI has announced that the device will be discontinued, and a lifetime-buy period is in effect.

NRND: Not recommended for new designs. Device is in production to support existing customers, but TI does not recommend using this part in a new design.

PREVIEW: Device has been announced but is not in production. Samples may or may not be available.

OBSELETE: TI has discontinued the production of the device.

⁽²⁾ Eco Plan - The planned eco-friendly classification: Pb-Free (RoHS), Pb-Free (RoHS Exempt), or Green (RoHS & no Sb/Br) - please check <http://www.ti.com> for more information and additional product content details.

TBD: The Pb-Free/Green conversion plan has not been defined.

Pb-Free (RoHS): TI's terms "Lead-Free" or "Pb-Free" mean semiconductor products that are compatible with the current RoHS requirements for all RoHS materials, with the exception of lead not exceed 0.1% by weight in homogeneous materials. Where designed to be soldered at high temperatures, TI Pb-Free products are suitable for use in applications that require high temperature soldering processes.

Pb-Free (RoHS Exempt): This component has a RoHS exemption for either 1) lead-based flip-chip solder bumps used between the die and package, or 2) lead-based eutectic solder used between the leadframe and die. The component is otherwise considered Pb-Free (RoHS compatible) as defined above.

Green (RoHS & no Sb/Br): TI defines "Green" to mean Pb-Free (RoHS compatible), and free of Bromine (Br) and Antimony (Sb) based flame retardants (unless otherwise designated in homogeneous material).

⁽³⁾ MSL, Peak Temp. -- The Moisture Sensitivity Level rating according to the JEDEC industry standard classifications, and peak solder temperature.

Important Information and Disclaimer: The information provided on this page represents TI's knowledge and belief as of the date that it is provided. TI does not warrant, represent, or make any representation as to the accuracy of such information. Efforts are underway to better integrate information from third parties, and makes no representation or warranty as to the accuracy of such information. Efforts are underway to better integrate information from third parties, and makes no representation or warranty as to the accuracy of such information. TI continues to take reasonable steps to provide representative and accurate information but may not have conducted destructive testing or chemical analysis on all TI and TI suppliers consider certain information to be proprietary, and thus CAS numbers and other limited information may not be available for release.

In no event shall TI's liability arising out of such information exceed the total purchase price of the TI part(s) at issue in this document sold by TI to Customer.

TAPE AND REEL INFORMATION



QUADRANT ASSIGNMENTS FOR PIN 1 ORIENTATION IN TAPE



*All dimensions are nominal

Device	Package Type	Package Drawing	Pins	SPQ	Reel Diameter (mm)	Reel Width W1 (mm)	A0 (mm)	B0 (mm)	K0 (mm)	P1 (mm)	W (mm)	Pin1 Quadrant
TPS65708YZHR	DSBGA	YZH	16	3000	180.0	8.4	2.18	2.18	0.81	4.0	8.0	Q1
TPS65708YZHT	DSBGA	YZH	16	250	180.0	8.4	2.18	2.18	0.81	4.0	8.0	Q1

TAPE AND REEL BOX DIMENSIONS



*All dimensions are nominal

Device	Package Type	Package Drawing	Pins	SPQ	Length (mm)	Width (mm)	Height (mm)
TPS65708YZHR	DSBGA	YZH	16	3000	190.5	212.7	31.8
TPS65708YZHT	DSBGA	YZH	16	250	190.5	212.7	31.8

YZH (S-XBGA-N16)

DIE-SIZE BALL GRID ARRAY

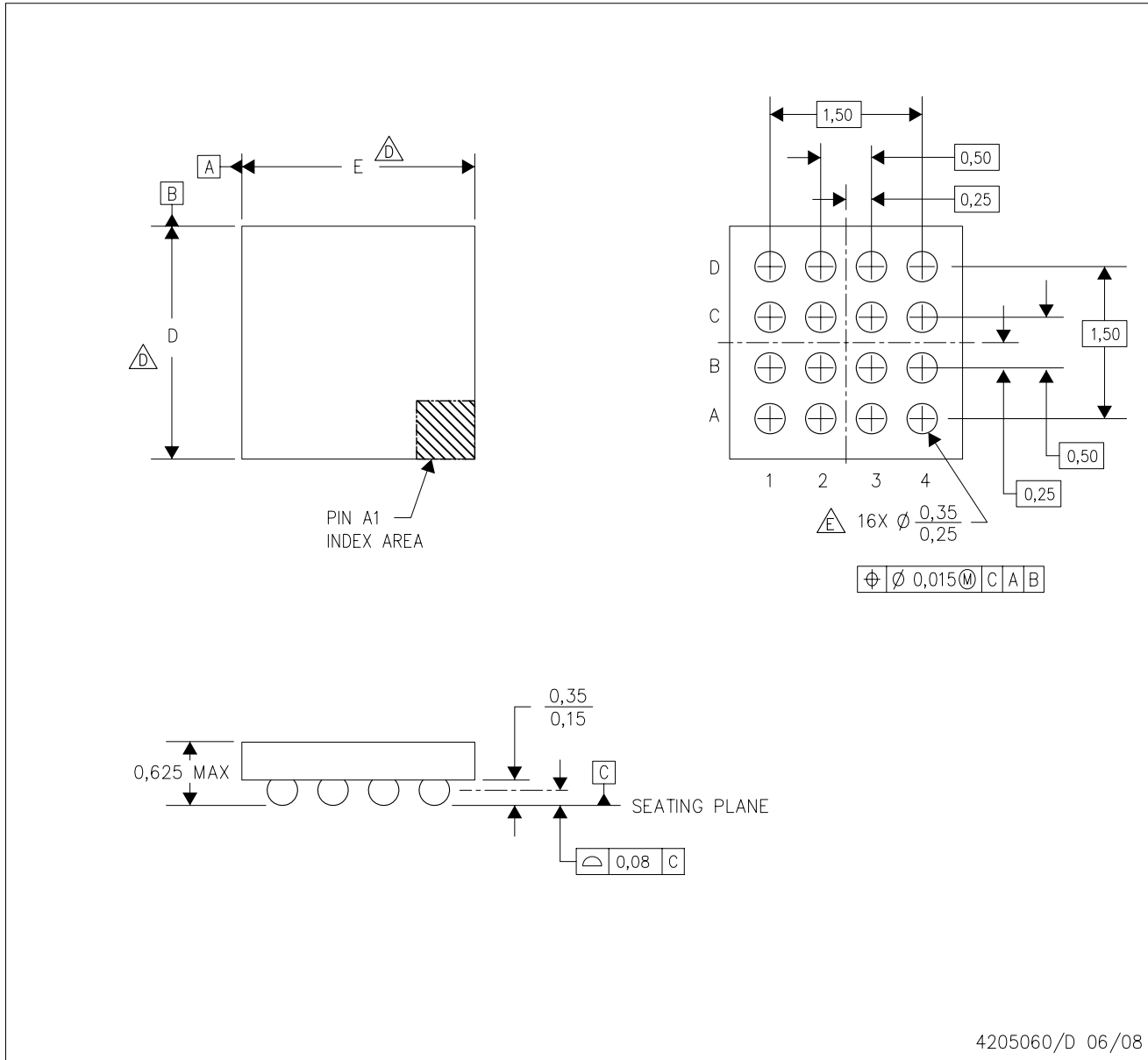

- NOTES:
- A. All linear dimensions are in millimeters.
 - B. This drawing is subject to change without notice.
 - C. NanoFree™ package configuration.
 - \triangle Devices in YZH package can have dimension D ranging from 1.94 to 2.65 mm and dimension E ranging from 1.94 to 2.65 mm. To determine the exact package size of a particular device, refer to the device datasheet or contact a local TI representative.
 - E. Reference Product Data Sheet for array population.
4 x 4 matrix pattern is shown for illustration only.
 - F. This package contains lead-free balls.
Refer to YEH (Drawing #4204183) for tin-lead (SnPb) balls.

NanoFree is a trademark of Texas Instruments.

IMPORTANT NOTICE

Texas Instruments Incorporated and its subsidiaries (TI) reserve the right to make corrections, modifications, enhancements, improvements, and other changes to its products and services at any time and to discontinue any product or service without notice. Customers should obtain the latest relevant information before placing orders and should verify that such information is current and complete. All products are sold subject to TI's terms and conditions of sale supplied at the time of order acknowledgment.

TI warrants performance of its hardware products to the specifications applicable at the time of sale in accordance with TI's standard warranty. Testing and other quality control techniques are used to the extent TI deems necessary to support this warranty. Except where mandated by government requirements, testing of all parameters of each product is not necessarily performed.

TI assumes no liability for applications assistance or customer product design. Customers are responsible for their products and applications using TI components. To minimize the risks associated with customer products and applications, customers should provide adequate design and operating safeguards.

TI does not warrant or represent that any license, either express or implied, is granted under any TI patent right, copyright, mask work right, or other TI intellectual property right relating to any combination, machine, or process in which TI products or services are used. Information published by TI regarding third-party products or services does not constitute a license from TI to use such products or services or a warranty or endorsement thereof. Use of such information may require a license from a third party under the patents or other intellectual property of the third party, or a license from TI under the patents or other intellectual property of TI.

Reproduction of TI information in TI data books or data sheets is permissible only if reproduction is without alteration and is accompanied by all associated warranties, conditions, limitations, and notices. Reproduction of this information with alteration is an unfair and deceptive business practice. TI is not responsible or liable for such altered documentation. Information of third parties may be subject to additional restrictions.

Resale of TI products or services with statements different from or beyond the parameters stated by TI for that product or service voids all express and any implied warranties for the associated TI product or service and is an unfair and deceptive business practice. TI is not responsible or liable for any such statements.

TI products are not authorized for use in safety-critical applications (such as life support) where a failure of the TI product would reasonably be expected to cause severe personal injury or death, unless officers of the parties have executed an agreement specifically governing such use. Buyers represent that they have all necessary expertise in the safety and regulatory ramifications of their applications, and acknowledge and agree that they are solely responsible for all legal, regulatory and safety-related requirements concerning their products and any use of TI products in such safety-critical applications, notwithstanding any applications-related information or support that may be provided by TI. Further, Buyers must fully indemnify TI and its representatives against any damages arising out of the use of TI products in such safety-critical applications.

TI products are neither designed nor intended for use in military/aerospace applications or environments unless the TI products are specifically designated by TI as military-grade or "enhanced plastic." Only products designated by TI as military-grade meet military specifications. Buyers acknowledge and agree that any such use of TI products which TI has not designated as military-grade is solely at the Buyer's risk, and that they are solely responsible for compliance with all legal and regulatory requirements in connection with such use.

TI products are neither designed nor intended for use in automotive applications or environments unless the specific TI products are designated by TI as compliant with ISO/TS 16949 requirements. Buyers acknowledge and agree that, if they use any non-designated products in automotive applications, TI will not be responsible for any failure to meet such requirements.

Following are URLs where you can obtain information on other Texas Instruments products and application solutions:

Products		Applications	
Amplifiers	amplifier.ti.com	Audio	www.ti.com/audio
Data Converters	dataconverter.ti.com	Automotive	www.ti.com/automotive
DLP® Products	www.dlp.com	Communications and Telecom	www.ti.com/communications
DSP	dsp.ti.com	Computers and Peripherals	www.ti.com/computers
Clocks and Timers	www.ti.com/clocks	Consumer Electronics	www.ti.com/consumer-apps
Interface	interface.ti.com	Energy	www.ti.com/energy
Logic	logic.ti.com	Industrial	www.ti.com/industrial
Power Mgmt	power.ti.com	Medical	www.ti.com/medical
Microcontrollers	microcontroller.ti.com	Security	www.ti.com/security
RFID	www.ti-rfid.com	Space, Avionics & Defense	www.ti.com/space-avionics-defense
RF/IF and ZigBee® Solutions	www.ti.com/lprf	Video and Imaging	www.ti.com/video
		Wireless	www.ti.com/wireless-apps