

Low Input Current, High Gain Optocouplers

Technical Data

6N139	6N138
HCPL-0701	HCPL-0700
HCNW139	HCNW138

Features

- **High Current Transfer Ratio**
– 2000% Typical (4500%
Typical for HCNW139/138)
- **Low Input Current**
Requirements – 0.5 mA
- **TTL Compatible Output –**
0.1 V V_{OL} Typical
- **Performance Guaranteed**
over Temperature 0°C
to 70°C
- **Base Access Allows Gain**
Bandwidth Adjustment
- **High Output Current –**
60 mA
- **Safety Approval**
UL Recognized – 2500 V rms
for 1 Minute and 5000 V rms*
for 1 Minute per UL 1577
CSA Approved
VDE 0884 Approved with
 $V_{IORM} = 1414 V_{peak}$ for
HCNW139 and HCNW138
BSI Certified (HCNW139 and
HCNW138)
- **Available in 8-Pin DIP or**
SOIC-8 Footprint or
Widebody Package
- **MIL-STD-1772 Version**
Available (HCPL-5700/1)

Applications

- **Ground Isolate Most Logic**
Families – TTL/TTL, CMOS/
TTL, CMOS/CMOS, LSTTL/
TTL, CMOS/LSTTL
- **Low Input Current Line**
Receiver
- **High Voltage Insulation**
(HCNW139/138)
- **EIA RS-232C Line Receiver**
- **Telephone Ring Detector**
- **117 V ac Line Voltage Status**
Indicator – Low Input Power
Dissipation
- **Low Power Systems –**
Ground Isolation

Description

These high gain series couplers use a Light Emitting Diode and an integrated high gain photodetector to provide extremely high current transfer ratio between input and output. Separate pins for the photodiode and output stage result in TTL compatible saturation voltages and high speed operation. Where desired the V_{CC} and V_O terminals may be tied together to achieve conventional photodarlington operation. A base access terminal allows a gain bandwidth adjustment to be made.

Functional Diagram

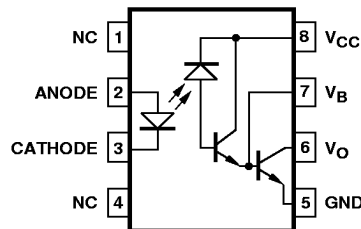

LED	V_O
ON	LOW
OFF	HIGH

*5000 V rms/1 minute rating is for HCNW139/138 and Option 020 (6N139/138) products only.
A 0.1 μF bypass capacitor connected between pins 8 and 5 is recommended.

CAUTION: It is advised that normal static precautions be taken in handling and assembly of this component to prevent damage and/or degradation which may be induced by ESD.

[查询"6N139#020"供应商](#)

The 6N139, HCPL-0701, and CNW139 are for use in CMOS, LSTTL or other low power applications. A 400% minimum current transfer ratio is guaranteed over 0 to 70°C operating range for only 0.5 mA of LED current.

The 6N138, HCPL-0700, and HCNW138 are designed for use mainly in TTL applications. Current Transfer Ratio (CTR) is 300% minimum over 0 to 70°C for an LED current of 1.6 mA

(1 TTL Unit load). A 300% minimum CTR enables operation with 1 TTL Load using a 2.2 k Ω pull-up resistor.

Selection for lower input current down to 250 μ A is available upon request.

The HCPL-0701 and HCPL-0700 are surface mount devices packaged in an industry standard SOIC-8 footprint.

The SOIC-8 does not require "through holes" in a PCB. This package occupies approximately one-third the footprint area of the standard dual-in-line package. The lead profile is designed to be compatible with standard surface mount processes.

The HCNW139 and HCNW138 are packaged in a widebody encapsulation that provides creepage and clearance dimensions suitable for safety approval by regulatory agencies worldwide.

Selection Guide

8-Pin DIP (300 Mil)		Small Outline SO-8		Widebody Package (400 mil)	Minimum Input ON Current (I_F)	Minimum CTR	Absolute Maxi- mum V_{CC}	Hermetic
Single Channel Package	Dual Channel Package HCPL-	Single Channel Package HCPL-	Dual Channel Package HCPL-	Single Channel Package				Single and Dual Channel Packages HCPL-
6N139	2731 ^[1]	0701	0731	HCNW139	0.5 mA	400%	18 V	
6N138	2730 ^[1]	0700	0730	HCNW138	1.6 mA	300%	7 V	
HCPL-4701 ^[1]	4731 ^[1]	070A ^[1]	073A ^[1]		40 μ A	800%	18 V	
					0.5 mA	300%	20 V	5701 ^[1] 5700 ^[1] 5731 ^[1] 5730 ^[1]

Note:

1. Technical data are on separate HP publications.

[查询"6N139#020"供应商](#)

Ordering Information

Specify Part Number followed by Option Number (if desired).

Example:

6N139#XXX

- 020 = 5000 V rms/1 Minute UL Rating Option*
- 300 = Gull Wing Surface Mount Option†
- 500 = Tape and Reel Packaging Option

Option data sheets available. Contact your Hewlett-Packard sales representative or authorized distributor for information.

*For 6N139 and 6N138 only.

†Gull wing surface mount option applies to through hole parts only.

Schematic

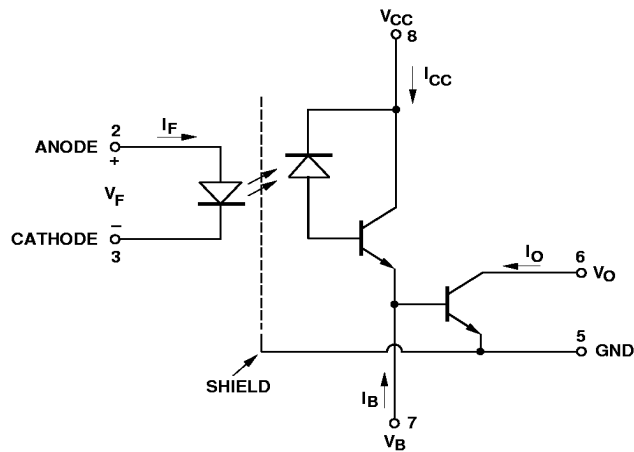

[查询"6N139#020"供应商](#)

Package Outline Drawings 8-Pin DIP Package (6N139/6N138)**

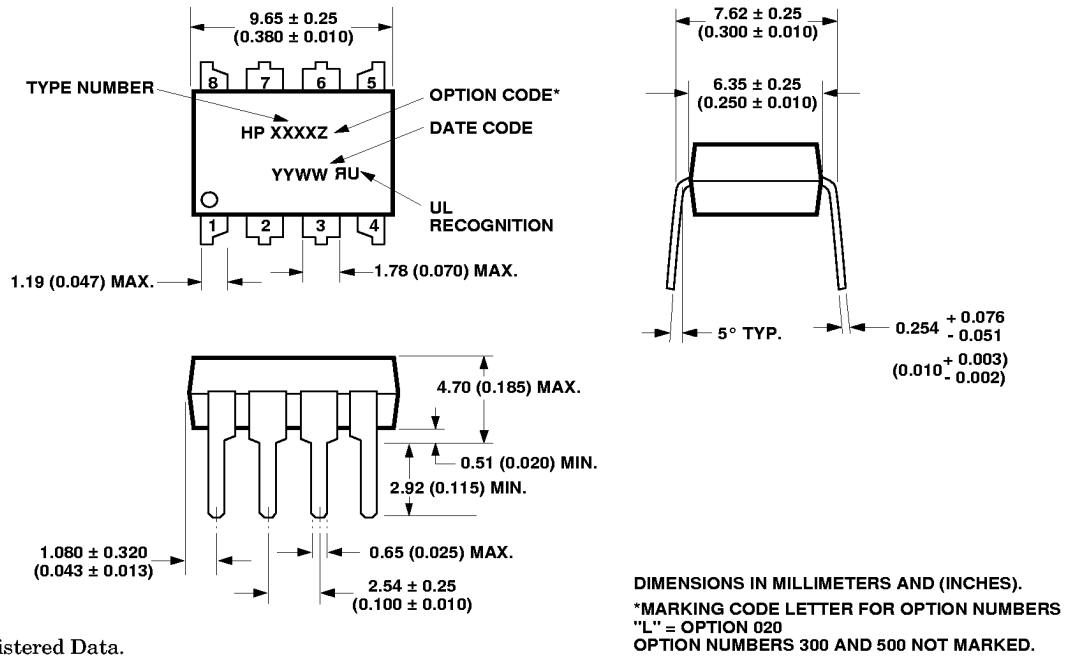

**JEDEC Registered Data.

8-Pin DIP Package with Gull Wing Surface Mount Option 300 (6N139/6N138)

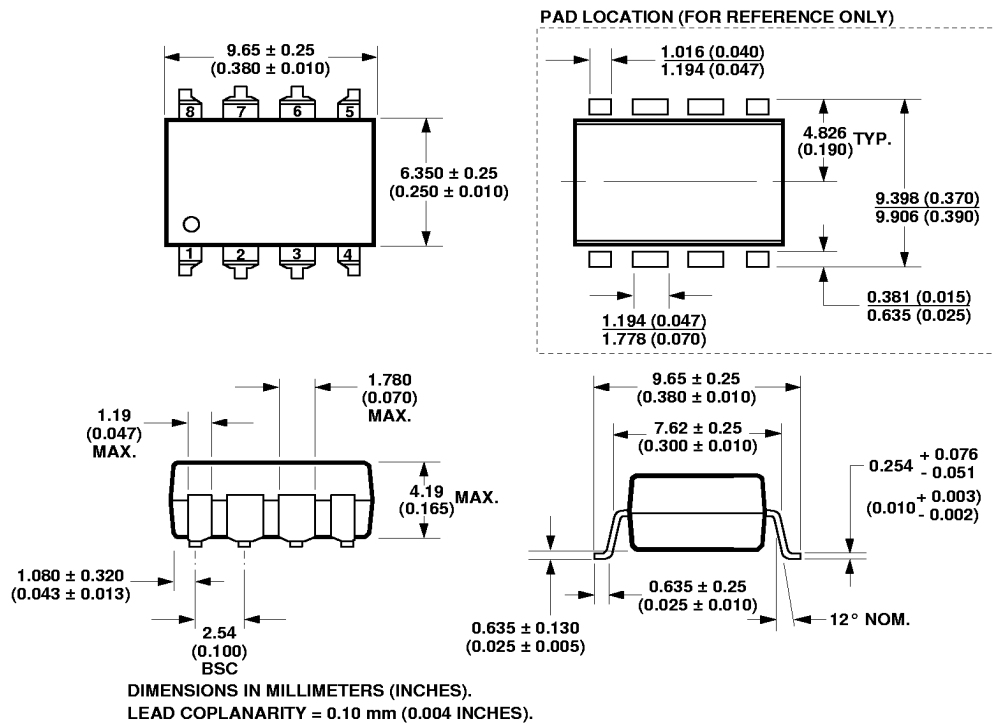

[查询"6N139#020"供应商](#)

Small Outline SO-8 Package (HCPL-0701/HCPL-0700)

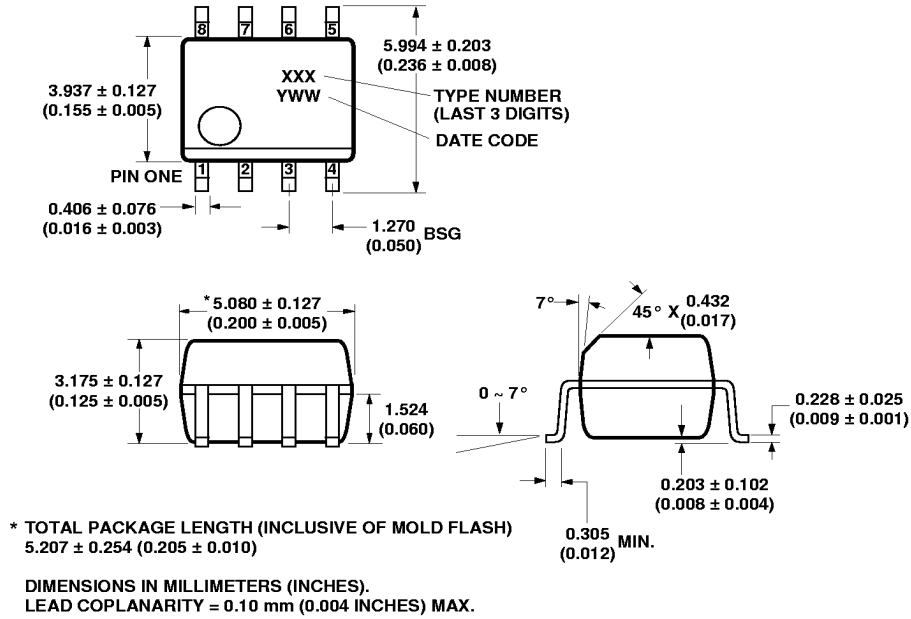

8-Pin Widebody DIP Package (HCNW139/HCNW138)

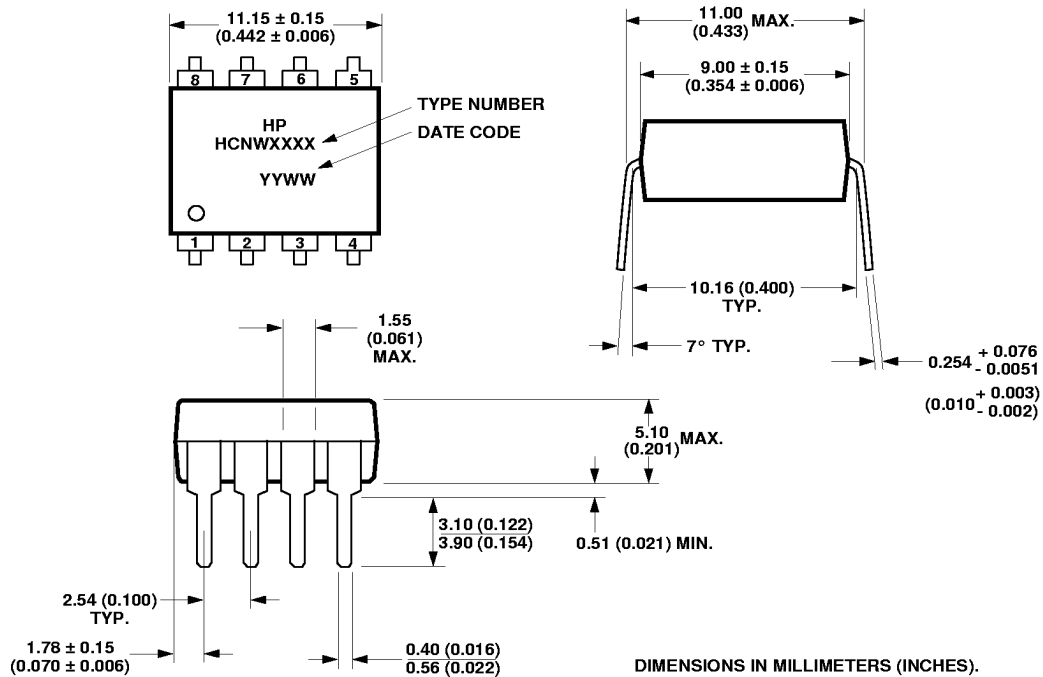

[查询"6N139#020"供应商](#)

8-Pin Widebody DIP Package with Gull Wing Surface Mount Option 300 (HCNW139/HCNW138)

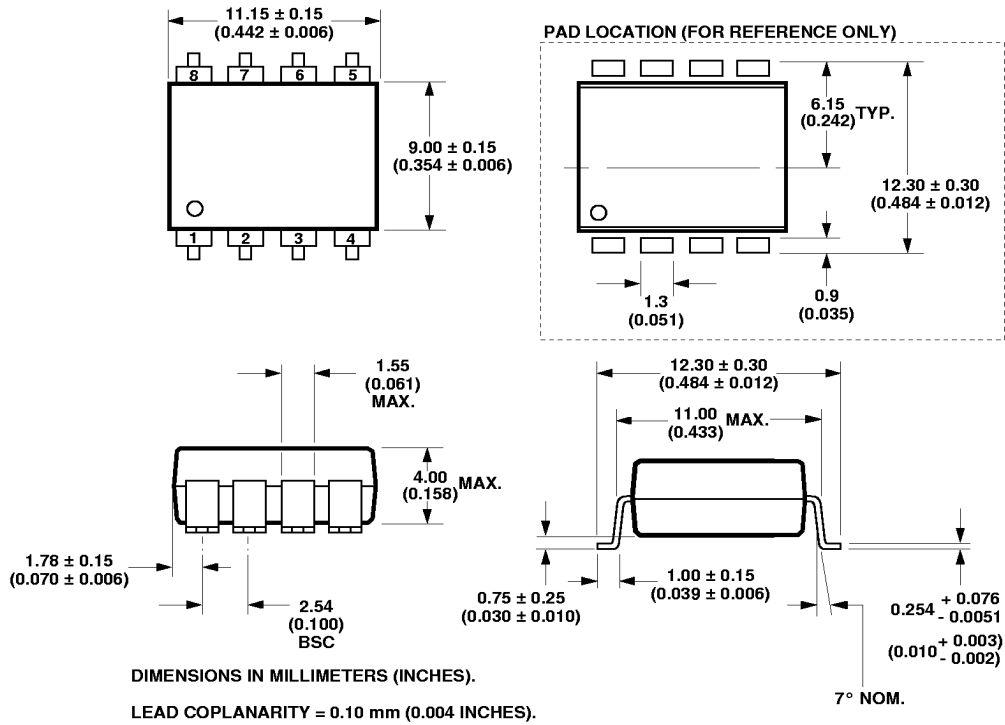

Solder Reflow Temperature Profile (HCPL-07XX and Gull Wing Surface Mount Option 300 Parts)

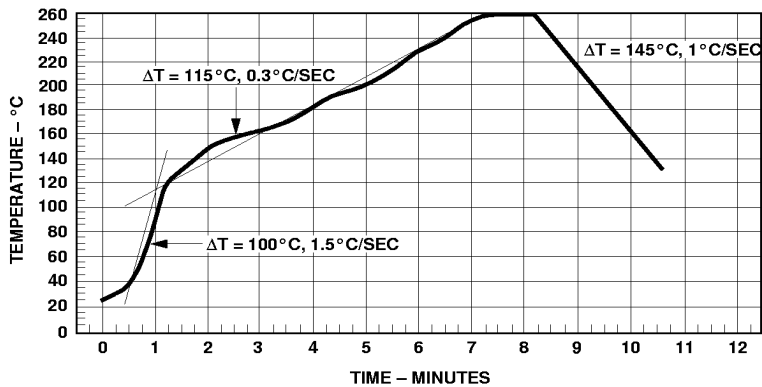

Note: Use of nonchlorine activated fluxes is highly recommended.

[查询"6N139#020"供应商](#)

Regulatory Information

The 6N139/138, HCNW139/138, and HCPL-0701/0700 have been approved by the following organizations:

UL

Recognized under UL 1577, Component Recognition Program, File E55361.

CSA

Approved under CSA Component Acceptance Notice #5, File CA 88324.

VDE

Approved according to VDE 0884/06.92 (HCNW139/138 only).

BSI

Certification according to BS415:1994, (BS EN60065:1994); BS EN60950:1992 (BS7002:1992) and EN41003:1993 for Class II applications (HCNW139/HCNW138 only.)

Insulation and Safety Related Specifications

Parameter	Symbol	8-Pin DIP (300 Mil) Value	SO-8 Value	Widebody (400 Mil) Value	Units	Conditions
Minimum External Air Gap (External Clearance)	L(101)	7.1	4.9	9.6	mm	Measured from input terminals to output terminals, shortest distance through air.
Minimum External Tracking (External Creepage)	L(102)	7.4	4.8	10.0	mm	Measured from input terminals to output terminals, shortest distance path along body.
Minimum Internal Plastic Gap (Internal Clearance)		0.08	0.08	1.0	mm	Through insulation distance, conductor to conductor, usually the direct distance between the photoemitter and photodetector inside the optocoupler cavity.
Minimum Internal Tracking (Internal Creepage)		NA	NA	4.0	mm	Measured from input terminals to output terminals, along internal cavity.
Tracking Resistance (Comparative Tracking Index)	CTI	200	200	200	Volts	DIN IEC 112/VDE 0303 Part 1
Isolation Group		IIIa	IIIa	IIIa		Material Group (DIN VDE 0110, 1/89, Table 1)

Option 300 - surface mount classification is Class A in accordance with CECC 00802.

[查询"6N139#020"供应商](#)

VDE 0884 Insulation Related Characteristics (HCNW139 and HCNW138)

Description	Symbol	Characteristic	Units
Installation Classification per DIN VDE 0110/1.89, Table 1 for rated mains voltage ≤ 600 V rms for rated mains voltage ≤ 1000 V rms		I-IV	
		I-III	
Climatic Classification		55/100/21	
Pollution Degree (DIN VDE 0110/1.89)		2	
Maximum Working Insulation Voltage	V_{IORM}	1414	V _{peak}
Input to Output Test Voltage, Method b* $V_{PR} = 1.875 \times V_{IORM}$, 100% Production Test with $t_p = 1$ sec, Partial Discharge < 5 pC	V_{PR}	2652	V _{peak}
Input to Output Test Voltage, Method a* $V_{PR} = 1.5 \times V_{IORM}$, Type and Sample Test, $t_p = 60$ sec, Partial Discharge < 5 pC	V_{PR}	2121	V _{peak}
Highest Allowable Overvoltage* (Transient Overvoltage, $t_{ini} = 10$ sec)	V_{IOTM}	8000	V _{peak}
Safety Limiting Values (Maximum values allowed in the event of a failure, also see Figure 11, Thermal Derating curve.) Case Temperature Current (Input Current I_F , $P_S = 0$) Output Power	T_S	175	°C
	$I_{S,INPUT}$	400	mA
	$P_{S,OUTPUT}$	700	mW
Insulation Resistance at T_S , $V_{IO} = 500$ V	R_S	$> 10^9$	Ω

*Refer to the front of the optocoupler section of the current catalog, under Product Safety Regulations section, (VDE 0884) for a detailed description.

Note: Isolation characteristics are guaranteed only within the safety maximum ratings which must be ensured by protective circuits in application.

[查询"6N139#020"供应商](#)

Absolute Maximum Ratings* (No Derating Required up to 85°C)

Parameter	Symbol	Min.	Max.	Units
Storage Temperature	T_S	-55	125	°C
Operating Temperature**	T_A	-40	85	°C
Average Forward Input Current	$I_{F(AVG)}$		20	mA
Peak Forward Input Current (50% Duty Cycle, 1 ms Pulse Width)	$I_{F(PK)}$		40	mA
Peak Transient Input Current (<1 μ s Pulse Width, 300 pps)	$I_{F(TRAN)}$		1.0	A
Reverse Input Voltage	V_R		5	V
HCNW139/138			3	V
Input Power Dissipation	P_I		35	mW
Output Current (Pin 6)	I_O		60	mA
Emitter Base Reverse Voltage (Pin 5-7)	V_{EB}		0.5	V
Supply Voltage and Output Voltage (6N139, HCPL-0701, HCNW139)	V_{CC}	-0.5	18	V
Supply Voltage and Output Voltage (6N138, HCPL-0700, HCNW138)	V_{CC}	-0.5	7	V
Output Power Dissipation	P_O		100	mW
Total Power Dissipation	P_T		135	mW
Lead Solder Temperature (for Through Hole Devices)	260°C for 10 sec., 1.6 mm below seating plane			
HCNW139/138	260°C for 10 sec., up to seating plane			
Reflow Temperature Profile (for SOIC-8 and Option #300)	See Package Outline Drawings section			

*JEDEC Registered Data for 6N139 and 6N138.

**0°C to 70°C on JEDEC Registration.

Recommended Operating Conditions

Parameter	Symbol	Min.	Max.	Units
Power Supply Voltage	V_{CC}	4.5	18	V
Forward Input Current (ON)	$I_{F(ON)}$	0.5	12.0	mA
Forward Input Voltage (OFF)	$V_{F(OFF)}$	0	0.8	V
Operating Temperature	T_A	0	70	°C

[查询"6N139#020"供应商](#)

Electrical Specifications

$0^{\circ}\text{C} \leq T_A \leq 70^{\circ}\text{C}$, $4.5\text{ V} \leq V_{CC} \leq 18\text{ V}$, $0.5\text{ mA} \leq I_{F(\text{ON})} \leq 12\text{ mA}$, $0\text{ V} \leq V_{F(\text{OFF})} \leq 0.8\text{ V}$, unless otherwise specified. All Typicals at $T_A = 25^{\circ}\text{C}$. See Note 7.

Parameter	Sym.	Device	Min.	Typ.**	Max.	Units	Test Conditions	Fig.	Note	
Current Transfer Ratio	CTR	6N139 HCPL-0701	400*	2000	5000	%	$I_F = 0.5\text{ mA}$ $V_{CC} = 4.5\text{ V}$ $V_O = 0.4\text{ V}$	2, 3	1, 2, 4	
		HCNW139	400	4500						
		6N139 HCPL-0701	500*	1600	2600		$I_F = 1.6\text{ mA}$			
		HCNW139	500	3000						
			300	1600			$I_F = 5.0\text{ mA}$			
			200	850						$I_F = 12\text{ mA}$
		6N138 HCPL-0700	300*	1600	2600		$I_F = 1.6\text{ mA}$			
		HCNW138		1500						
Logic Low Output Voltage	V_{OL}	6N139 HCPL-0701 HCNW139		0.1	0.4	V	$I_F = 0.5\text{ mA}$, $I_O = 2\text{ mA}$	$V_{CC} = 4.5$	1	2
							$I_F = 5.0\text{ mA}$, $I_O = 15\text{ mA}$			
			0.2							
		6N138 HCPL-0700 HCNW138		0.1			$I_F = 1.6\text{ mA}$, $I_O = 4.8\text{ mA}$			
Logic High Output Current	I_{OH}	6N139 HCPL-0701 HCNW139		0.05	100	μA	$V_O = V_{CC} = 18\text{ V}$	$I_F = 0\text{ mA}$		2
		6N138 HCPL-0700 HCNW138		0.1	250		$V_O = V_{CC} = 7\text{ V}$			
Logic Low Supply Current	I_{CCL}	6N138/139 HCPL-0701/ 0700		0.4	1.5	mA	$I_F = 1.6\text{ mA}$, $V_O = \text{Open}$, $V_{CC} = 18\text{ V}$	10	2	
		HCNW139 HCNW138		0.5	2					
Logic High Supply Current	I_{CCH}	6N138/139 HCPL-0701/ 0700		0.01	10	μA	$I_F = 0\text{ mA}$, $V_O = \text{Open}$, $V_{CC} = 18\text{ V}$		2	
		HCNW139 HCNW138			1					
Input Forward Voltage	V_F	6N138 6N139	1.25	1.40	1.7*	V	$T_A = 25^{\circ}\text{C}$	$I_F = 1.6\text{ mA}$	4, 8	
		HCPL-0701 HCPL-0700			1.75					
		HCNW139 HCNW138	1.0	1.45	1.85		$T_A = 25^{\circ}\text{C}$			
			0.95		1.95					
Input Reverse Breakdown Voltage	BVR		5.0*			V	$I_R = 10\text{ }\mu\text{A}$, $T_A = 25^{\circ}\text{C}$			
		HCNW139 HCNW138	3.0				$I_R = 100\text{ }\mu\text{A}$, $T_A = 25^{\circ}\text{C}$			
Temperature Coefficient of Forward Voltage	$\frac{\Delta V_F}{\Delta T_A}$			-1.8		mV/ $^{\circ}\text{C}$	$I_F = 1.6\text{ mA}$	8		
Input Capacitance	C_{IN}			60		pF	$f = 1\text{ MHz}$, $V_F = 0\text{ V}$			
		HCNW139 HCNW138		90						

*JEDEC Registered Data for 6N139 and 6N138.

**All typical values at $T_A = 25^{\circ}\text{C}$ and $V_{CC} = 5\text{ V}$, unless otherwise noted.

[查询"6N139#020"供应商](#)

Switching Specifications (AC)

Over recommended operating conditions ($T_A = 0$ to 70°C), $V_{CC} = 5$ V, unless otherwise specified.

Parameter	Sym.	Device	Min.	Typ.**	Max.	Units	Test Conditions	Fig.	Note		
Propagation Delay Time to Logic Low at Output	t_{PHL}	6N139		5	25*	μs	$T_A = 25^\circ\text{C}$	5, 6, 7, 9, 12	2, 4		
		HCPL-0701			30		$I_F = 0.5$ mA, $R_l = 4.7$ k Ω				
		HCNW139									
		6N139	HCPL-0701		0.2	1*	μs			$T_A = 25^\circ\text{C}$	
						2				$I_F = 12$ mA, $R_l = 270$ Ω	
						HCNW139				1.1	
		6N138	HCPL-0700		1.6	10*	μs			$T_A = 25^\circ\text{C}$	
						HCNW138				15	$I_F = 1.6$ mA, $R_l = 2.2$ k Ω
						HCNW138				11	
Propagation Delay Time to Logic High at Output	t_{PLH}	6N139		18	60*	μs	$T_A = 25^\circ\text{C}$	5, 6, 7, 9, 12	2, 4		
		HCPL-0701			90		$I_F = 0.5$ mA, $R_l = 4.7$ k Ω				
		HCNW139			115						
		6N139	HCPL-0701		2	7*	μs			$T_A = 25^\circ\text{C}$	
						HCNW139				10	$I_F = 12$ mA, $R_l = 270$ Ω
						HCNW139				1.1	
		6N138	HCPL-0700		10	35*	μs			$T_A = 25^\circ\text{C}$	
						HCNW138					$I_F = 1.6$ mA, $R_l = 2.2$ k Ω
						6N138				50	
		HCPL-0700			70						
		HCNW139									
Common Mode Transient Immunity at Logic High Output	$ CM_H $		1000	10000		V/ μs	$I_F = 0$ mA, $T_A = 25^\circ\text{C}$ $R_l = 2.2$ k Ω $ V_{CM} = 10$ V _{p-p}	13	5, 6		
Common Mode Transient Immunity at Logic Low Output	$ CM_L $		1000	10000		V/ μs	$I_F = 1.6$ mA, $T_A = 25^\circ\text{C}$ $R_l = 2.2$ k Ω $ V_{CM} = 10$ V _{p-p}	13	5, 6		

*JEDEC Registered Data for 6N139 and 6N138.

**All typical values at $T_A = 25^\circ\text{C}$ and $V_{CC} = 5$ V, unless otherwise noted.

Package Characteristics

Parameter	Sym.	Min.	Typ.**	Max.	Units	Test Conditions	Fig.	Note
Input-Output Momentary Withstand Voltage†	V _{ISO}	2500			V rms	RH < 50%, t = 1 min., T _A = 25°C		3, 8
		5000						3, 9
Resistance (Input-Output)	R _{I-O}		10 ¹²		Ω	V _{I-O} = 500 Vdc RH < 45%		3
Capacitance (Input-Output)	C _{I-O}		0.6		pF	f = 1 MHz		3

**All typicals at T_A = 25°C, unless otherwise noted.

†The Input-Output Momentary Withstand Voltage is a dielectric voltage rating that should not be interpreted as an input-output continuous voltage rating. For the continuous voltage rating refer to the VDE 0884 Insulation Characteristics Table (if applicable), your equipment level safety specification or HP Application Note 1074 entitled "Optocoupler Input-Output Endurance Voltage."

Notes:

- DC CURRENT TRANSFER RATIO (CTR) is defined as the ratio of output collector current, I_O, to the forward LED input current, I_F, times 100%.
- Pin 7 Open.
- Device considered a two-terminal device. Pins 1, 2, 3, and 4 shorted together and Pins 5, 6, 7, and 8 shorted together.
- Use of a resistor between pin 5 and 7 will decrease gain and delay time. Significant reduction in overall gain can occur when using resistor values below 47 kΩ. For more information, please contact your local HP Components representative.
- Common mode transient immunity in a Logic High level is the maximum toler-

- able (positive) dV_{CM}/dt of the common mode pulse, V_{CM}, to assure that the output will remain in a Logic High state (i.e., V_O > 2.0 V). Common mode transient immunity in a Logic Low level is the maximum tolerable (negative) dV_{CM}/dt of the common mode pulse, V_{CM}, to assure that the output will remain in a Logic Low state (i.e., V_O < 0.8 V).
- In applications where dV/dt may exceed 50,000 V/μs (such as static discharge) a series resistor, R_{CC}, should be included to protect the detector IC from destructively high surge currents. The recommended value is R_{CC} = 220 Ω.
 - Use of a 0.1 μF bypass capacitor connected between pins 8 and 5 adjacent to the device is recommended.

- In accordance with UL 1577, each optocoupler is proof tested by applying an insulation test voltage 3000 V rms for 1 second (leakage detection current limit, I_{I-O} < 5 μA). This test is performed before the 100% production test shown in the VDE 0884 Insulation Related Characteristics Table, if applicable.
- In accordance with UL 1577, each optocoupler is proof tested by applying an insulation test voltage > 6000 V rms for 1 second (leakage detection current limit, I_{I-O} < 5 μA). This test is performed before the 100% production test for partial discharge (method b) shown in the VDE 0884 Insulation Related Characteristics Table, if applicable.

[查询"6N139#020"供应商](#)

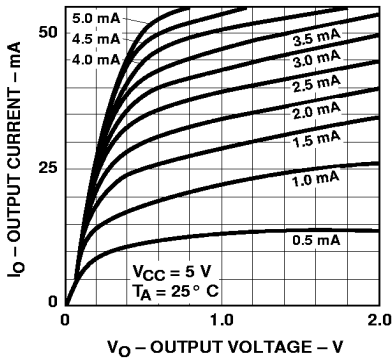

Figure 1. 6N138/6N139 DC Transfer Characteristics.

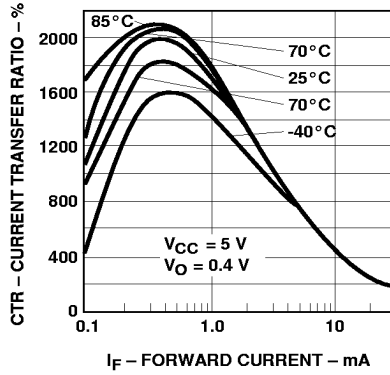

Figure 2. Current Transfer Ratio vs. Forward Current 6N138/6N139.

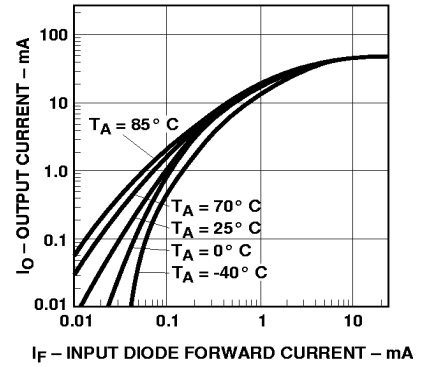

Figure 3. 6N138/6N139 Output Current vs. Input Diode Forward Current.

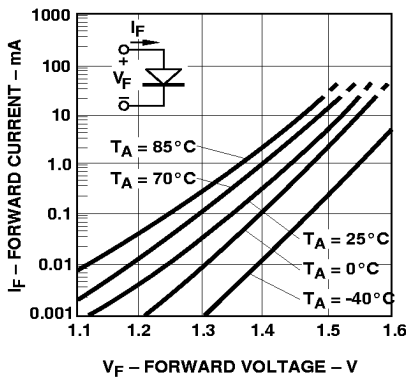

Figure 4. Input Diode Forward Current vs. Forward Voltage.

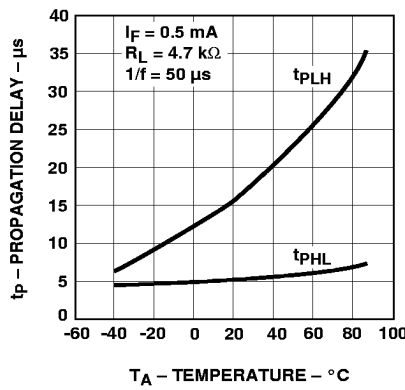

Figure 5. Propagation Delay vs. Temperature.

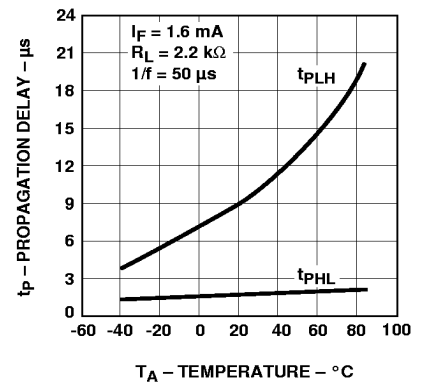

Figure 6. Propagation Delay vs. Temperature.

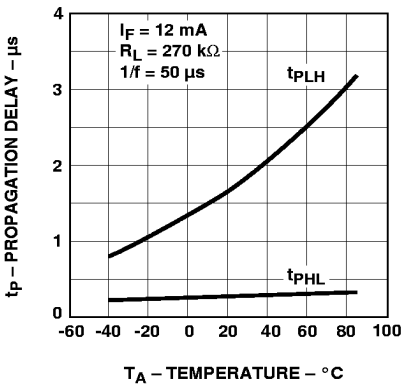

Figure 7. Propagation Delay vs. Temperature.

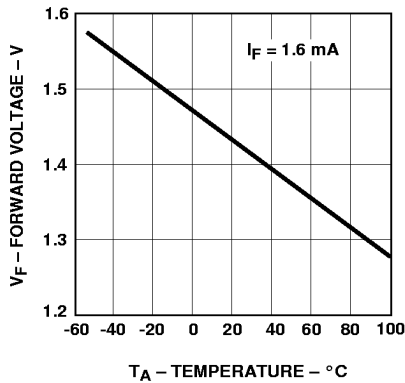

Figure 8. Forward Voltage vs. Temperature.

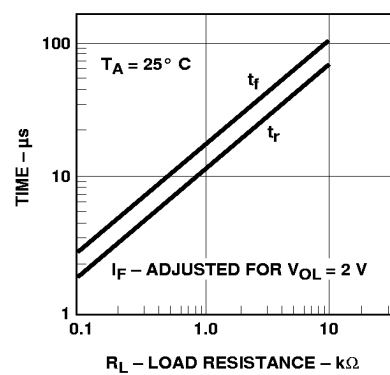

Figure 9. Nonsaturated Rise and Fall Times vs. Load Resistance.

[查询"6N139#020"供应商](#)

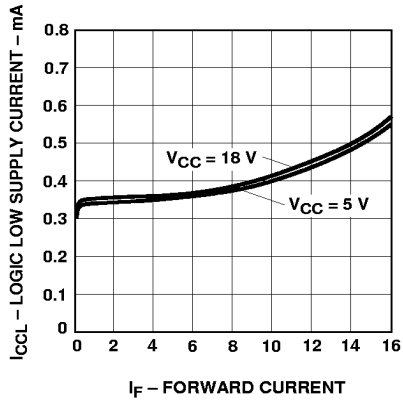

Figure 10. Logic Low Supply Current vs. Forward Current.

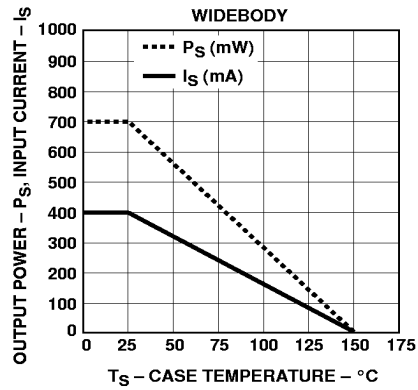

Figure 11. Thermal Derating Curve, Dependence of Safety Limiting Value with Case Temperature per VDE 0884.

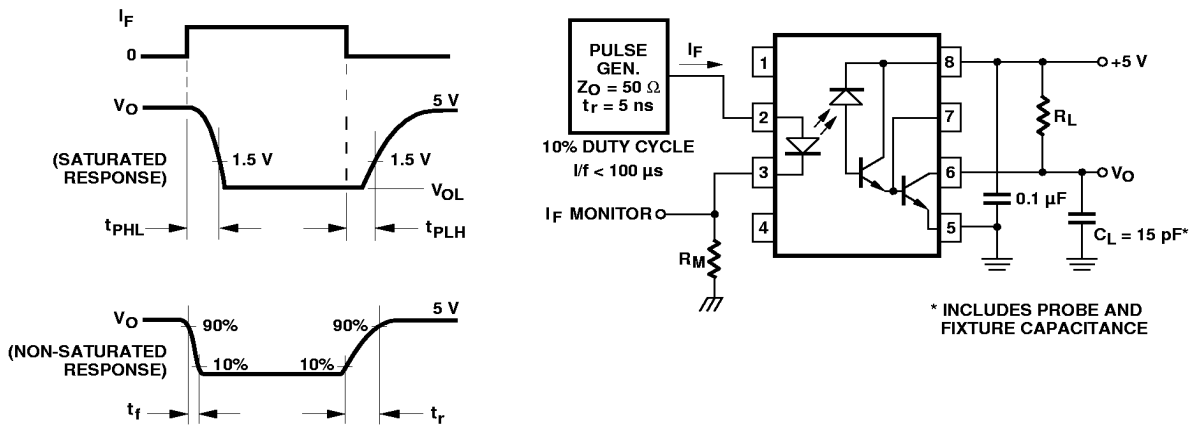

Figure 12. Switching Test Circuit.

[查询"6N139#020"供应商](#)

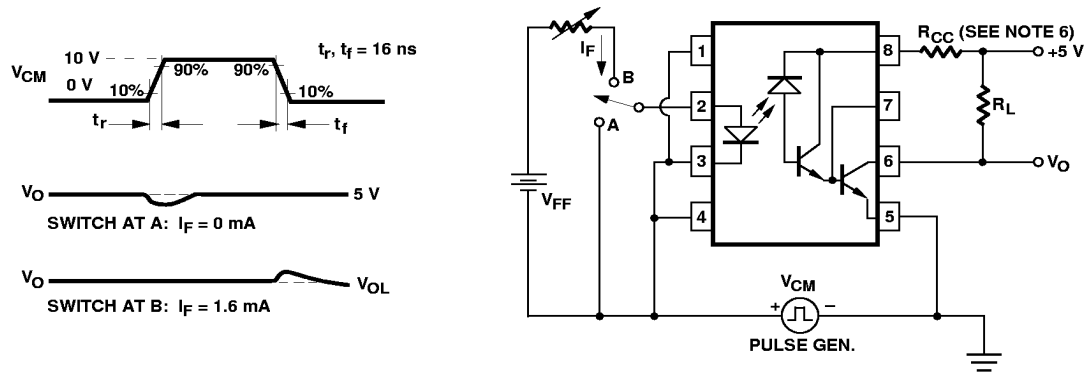

Figure 13. Test Circuit for Transient Immunity and Typical Waveforms.