



# Z90356 ROM Z90351 OTP

64 KWORD TELEVISION CONTROLLER WITH OSD

PRODUCT SPECIFICATION

PS002700-TVC1199



## **Document Disclaimer**

© 1999 by ZiLOG, Inc. All rights reserved. Information in this publication concerning the devices, applications, or technology described is intended to suggest possible uses and may be superseded. ZiLOG, INC. DOES NOT ASSUME LIABILITY FOR OR PROVIDE A REPRESENTATION OF ACCURACY OF THE INFORMATION, DEVICES, OR TECHNOLOGY DESCRIBED IN THIS DOCUMENT. ZiLOG ALSO DOES NOT ASSUME LIABILITY FOR INTELLECTUAL PROPERTY INFRINGEMENT RELATED IN ANY MANNER TO USE OF INFORMATION, DEVICES, OR TECHNOLOGY DESCRIBED HEREIN OR OTHERWISE. Except with the express written approval ZiLOG, use of information, devices, or technology as critical components of life support systems is not authorized. No licenses or other rights are conveyed, implicitly or otherwise, by this document under any intellectual property rights.



## Table of Contents

1	Overview .....	11
1.1	Block Diagram .....	14
1.2	Pin Description .....	15
2	Operation .....	17
2.1	CPU Descriptions .....	17
2.2	Memory (ROM and RAM) .....	24
2.3	Clock Circuit Description .....	26
2.4	Reset Conditions .....	28
2.5	Power Management .....	30
2.6	I/O Port Configurations .....	30
2.7	Interrupts .....	32
2.8	Timers .....	33
2.9	ADC .....	34
2.10	Pulse Width Modulation .....	36
2.11	I2C Interface .....	36
2.12	On-Screen Display (OSD) .....	42
2.13	Cursor .....	48
2.14	Color Palette Assignment .....	52
2.15	Other Functions .....	53
3	Register Groups.....	55
3.1	Register Description .....	56
3.2	Bank0 Control Registers .....	57
3.3	Bank1 (Control Registers) .....	63
3.4	Bank2 (PWM Registers) .....	75
3.5	Bank3 (On Screen Display [OSD] Registers) .....	78
4	Instruction Set .....	91
4.1	Instruction Summary .....	91
4.2	Instruction Operands .....	94
4.3	Instruction Format .....	95
4.4	Instruction Bit Codes .....	97
4.5	Instruction Format Examples .....	100
4.6	Instruction Timing .....	105
4.7	Instruction Op Codes .....	106



5	Electrical Characteristics .....	177
5.1	DC Peripherals .....	178
5.2	AC Characteristics .....	180
5.3	ANALOG RGB .....	181
6	System Design Considerations .....	182
7	Packaging .....	183



## List of Figures

Figure 1	Code Development Environment . . . . .	11
Figure 2	Block Diagram . . . . .	14
Figure 3	52-Pin SDIP Pinout . . . . .	15
Figure 4	AR Register Format . . . . .	21
Figure 5	RAM, ROM, and Pointer Architecture . . . . .	24
Figure 6	ROM Map . . . . .	25
Figure 7	RAM Allocation . . . . .	26
Figure 8	Clock Switching Block Diagram . . . . .	27
Figure 9	32-KHz Oscillator Recommended Circuit . . . . .	27
Figure 10	Bidirectional Port Pins . . . . .	31
Figure 11	Bidirectional Pins Multiplexed with I2C Port . . . . .	31
Figure 12	Bidirectional Pins Multiplexed with ADC Inputs . . . . .	32
Figure 13	IR Capture Register Block Diagram . . . . .	33
Figure 14	ADC Block Diagram . . . . .	35
Figure 15	ADC Data Packing . . . . .	36
Figure 16	Master Mode . . . . .	40
Figure 17	Slave Mode . . . . .	41
Figure 18	Data Flow . . . . .	43
Figure 19	Blank and V1, V2, V3 Outputs in Digital Mode . . . . .	43
Figure 20	V1, V2, and V3 Outputs in Analog (Palette) Mode . . . . .	44
Figure 21	Character Expansion . . . . .	45
Figure 22	Table Settings . . . . .	47
Figure 23	Cursor . . . . .	49
Figure 24	Programmable Palette Control at AR Register . . . . .	53
Figure 25	IR Capture Register Input . . . . .	53
Figure 26	Loop Filter Pin Configuration . . . . .	54
Figure 27	Pipeline Execution . . . . .	106
Figure 28	Recommended Application Schematics . . . . .	181
Figure 29	System Block Diagram . . . . .	183
Figure 30	52-Pin SDIP Package Dimensions . . . . .	184



**Z90356 ROM and Z90351 OTP  
64 KWord Television Controller with OSD**

---



## List of Tables

Table 1	Z90356 or Z90351 Pin Description	15
Table 2	Internal Registers	18
Table 3	Status Register	19
Table 4	RPL Description	20
Table 5	Additional Control Registers	22
Table 6	Reset Conditions	28
Table 7	ADC Inputs Typical Range	34
Table 8	Master I2C Bus Bit Rates	37
Table 9	Master I2C Bus Interface Commands	38
Table 10	Slave I2C Bus Interface Commands	39
Table 11	Character Expansion Register	45
Table 12	Attribute Assignment	48
Table 13	Cursor Parameters	50
Table 14	Memory Allocation for Cursor's Bitmap	50
Table 15	Fixed Palette Color Assignment (Color0 is Black; Color7 is White)	52
Table 16	R4(1) <e:d> Settings	54
Table 17	Register Summary	55
Table 18	Bank Assignments	57
Table 19	Register1, R1(0) Cursor Palette	57
Table 20	Register2, R2(0) PLL Frequency Data Register	58
Table 21	Register3, R3(0) I2C Interface Register	60
Table 22	Register4, R4(0) Port 0 Data Register	61
Table 23	Register5, R5(0) Port 1 Data Register	62
Table 24	Register6, R6(0) Port 0 Direction Register	62
Table 25	Register7, R7(0) Port 1 Direction Register	63
Table 26	Register0, R0(1) Clamp Position Register	64
Table 27	Register1, R1(1) Speed Control Register	65
Table 28	Register2, R2(1) WDT/STOP (write only) and 9-Bit Counter (read only) Control Register	66
Table 29	Register3, R3(1) Standard Control Register	67
Table 30	Register4, R4(1) ADC Control Register	68
Table 31	Register5, R5(1) Timer Control Register	70
Table 32	Register6, R6(1) Clock Switch Control Register	71
Table 33	Register7, R7(1) Interrupts/WDT/SMR Control Register	74



Table 34	Interrupt Priority	75
Table 35	Register0–Register5, R0(2)–R5(2) PWM 1–6 Registers	76
Table 36	Register6, R6(2) Shadow Control Register	77
Table 37	Register7, R7(2) CGROM Offset Register	77
Table 38	Register0–Register2 Read Operation	78
Table 39	Register0–Register1 Write Operation R0(3)–R1(3) Shift Registers	79
Table 40	Register2 – R2(3) Attributes Register, Write Operation	79
Table 41	Register3 Read Operation R3(3) Attributes Register	81
Table 42	Register3, R3(3) Write Operation Attribute Data Register	82
Table 43	Display Character Format for Attribute Data Register R3(3)	83
Table 44	Control Character Format	84
Table 45	Display Character Format	85
Table 46	Control Character Format, Attribute Data Register R3(3) CCD Mode, Write Operation	86
Table 47	Register4–R4(3) OSD Control Register	87
Table 48	Register5, R5(3) Capture Register, Read Operation	88
Table 49	Register6, R6(3) Palette Control Register	89
Table 50	Register7, R7(3) Output Palette Control Register	90
Table 51	Instruction Format Mnemonics	91
Table 52	Accumulator Modification Instructions	92
Table 53	Arithmetic Instructions	92
Table 54	Bit Manipulation Instructions	92
Table 55	Load Instructions	93
Table 56	Logical Instructions	93
Table 57	Program Control Instructions	93
Table 58	Rotate and Shift Instructions	93
Table 59	Instruction Operand Summary	94
Table 60	Instruction Mnemonics/Operands	94
Table 61	Condition Code Bits	97
Table 62	Accumulator Modification Bits	98
Table 63	Flag Modification Bits	99
Table 64	Register Pointer/ Data Pointer Bits	99
Table 65	Register Bits	100
Table 66	General Instruction Format	102
Table 67	Accumulator Modification Format	103
Table 68	Flag Modification Format	103
Table 69	Direct Internal Addressing Format	104
Table 70	Short Immediate Addressing Format	104



Table 71	Long Immediate Addressing Format . . . . .	105
Table 72	Jump, Call Format . . . . .	105
Table 73	Instruction Op Codes . . . . .	106
Table 74	Instruction Descriptions . . . . .	111
Table 75	Instruction Format Mnemonics . . . . .	111
Table 76	Absolute Maximum and Minimum Ratings . . . . .	177
Table 77	DC Characteristics . . . . .	177
Table 78	V1, V2, and V3 (R,G,B) Analog Output . . . . .	178
Table 79	ADC0/Small Range* . . . . .	179
Table 80	ADC1-ADC4/Full Range . . . . .	180
Table 81	AC Characteristics . . . . .	180
Table 82	RGB Voltage Specification . . . . .	181
Table 83	RGB Time Specification . . . . .	181
Table 84	Controlling Dimensions . . . . .	185



**Z90356 ROM and Z90351 OTP  
64 KWord Television Controller with OSD**

---



## ***Z90356 ROM and Z90351 OTP 64 KWord Television Controller with OSD***

### **1 Overview**

The Z90356 and Z90351 are the ROM and OTP versions of a Television Controller with On-Screen Display (OSD) that contains 64 KWords of program memory and 1K words of RAM.

- The **Z90351** is the one-time programmable (OTP) controller used to develop code and prototypes for specific television applications or initial limited production. Program ROM and Character Generation ROM (CGROM) in the Z90351 are both programmable.

The Z90351 requires ZiLOG's Z90369ZEM Emulator with its proprietary ZiLOG Developmental Studio (ZDS) software for programing. To view code effects, the emulator uses a ZOSD board that connects directly to a television screen. Refer to Figure 1.

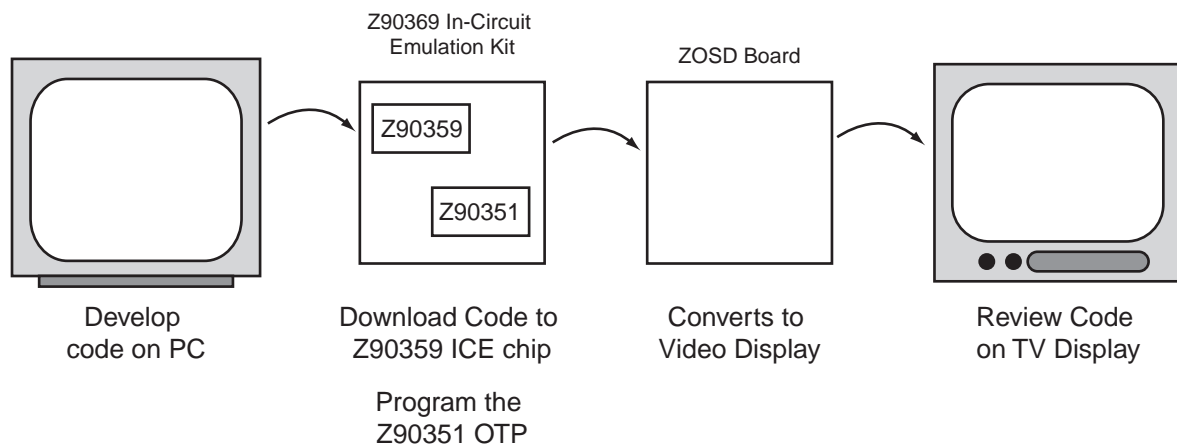

**Figure 1 Code Development Environment**



- The **Z90356** incorporates the ROM code developed by the customer with the Z90351. Customer code is masked into both program ROM and CGROM.

The Z90356 Television Controller with OSD is based on ZiLOG's Z89C00 RISC processor core. The Z89C00 is a second-generation, 16-bit, fractional, two's complement CMOS Digital Signal Processor (DSP). Most instructions are accomplished in a single clock cycle. This processor features a 24-bit Arithmetic Logic Unit (ALU) and a 24-bit Accumulator. The processor also contains a six-level stack and three vectored interrupts.

**Note:** The Z89C00 multiplier is disabled in the Z90356 controller.

The Z90356 contains 64 KWords of program ROM and 1 KWord of on-chip data RAM. Program ROM space can hold an unlimited number of characters with a 16x16, 16x18, and 16x20 programmable matrix in relocated Character Generation ROM (CGROM), which is only restricted by the available ROM. In addition, the Z90356 contains four external register banks with eight registers each. Additional Control Registers (AR) are available to control new peripheral blocks like palette banks and memory management.

An internal 24-MHz/2 system clock has a Phase Lock Loop (PLL) driven by an external 32.768-KHz crystal.

A six-channel, 4-bit Analog to Digital Converter (ADC) supports the following:

- Analog front panel control
- Audio level input
- Vertical Blanking Interval (VBI) data capture

Six Pulse Width Modulator (PWM) outputs allow low-cost digital-to-analog conversion (DAC). The PWMs have 8-bit resolution to control video and audio attributes.

A Master/Slave I<sup>2</sup>C (Inter Integrated Circuit) bus interface provides serial system interconnect to common peripheral functions.

Twenty-five programmable I/O pins provide flexibility for other digital input/output functions.

An IR (InfraRed) remote capture register facilitates reliable remote data capture.

On-chip Horizontal Synchronization (H<sub>SYNC</sub>) and Vertical Synchronization (V<sub>SYNC</sub>) circuits generate a video time base (typically used for VCR and set-top applications) in the absence of an available video signal.

Micro-programmable OSD generation logic provides flexibility to tailor OSD features and functions. In addition to normal OSD functions, Closed Caption is supported in accordance with FCC Report and Order on GEN Docket No. 91-1, dated April 12, 1991. Expanded Data Service (XDS) capability is supported as well.

The Z90356 is packaged in a 52-pin SDIP package.



Figure 2 is a block diagram of the internal structure of the chip. Figure 3 illustrates the pin locations, and Table 1 describes the function of each pin.

### 1.1 Block Diagram

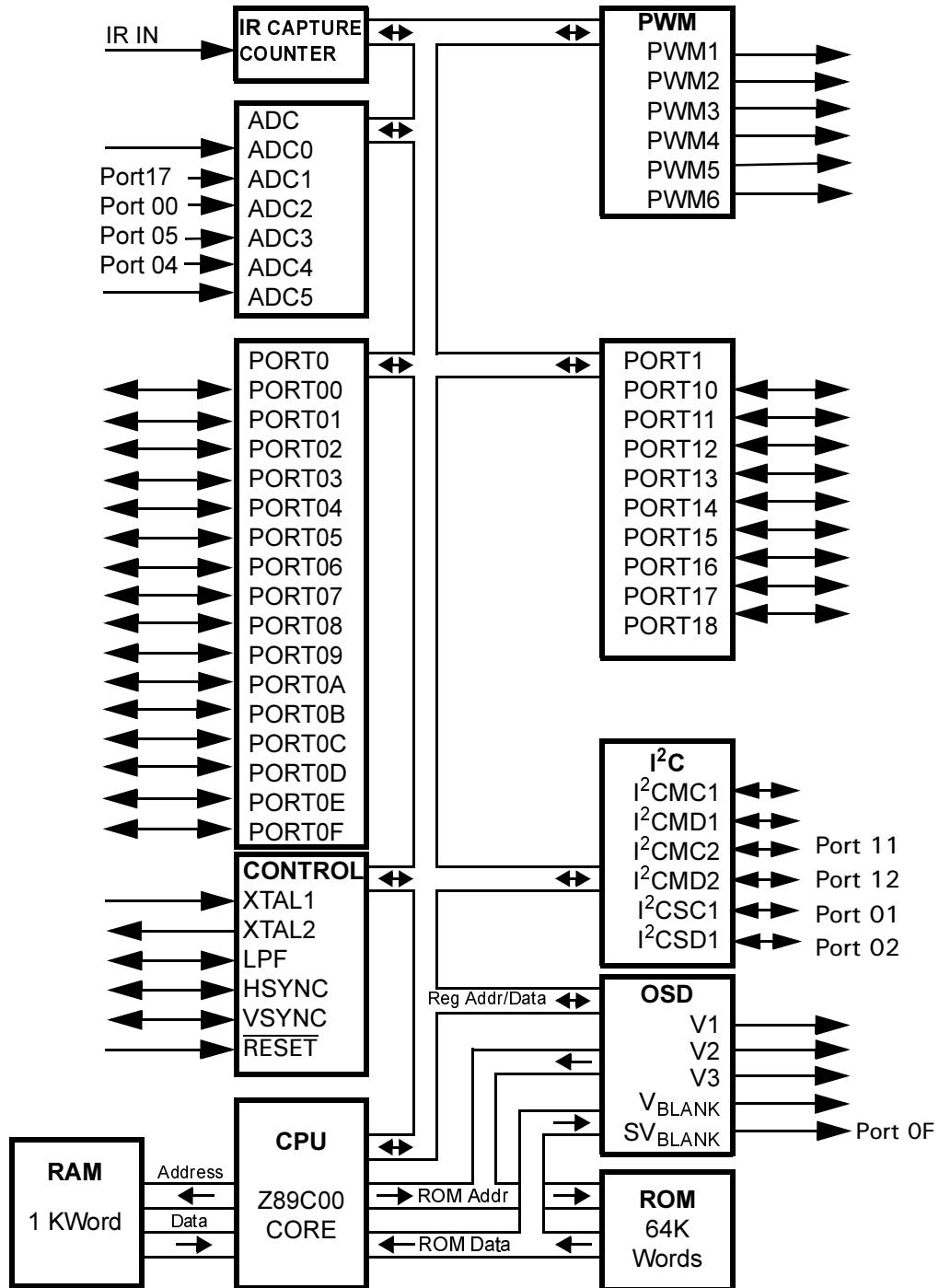
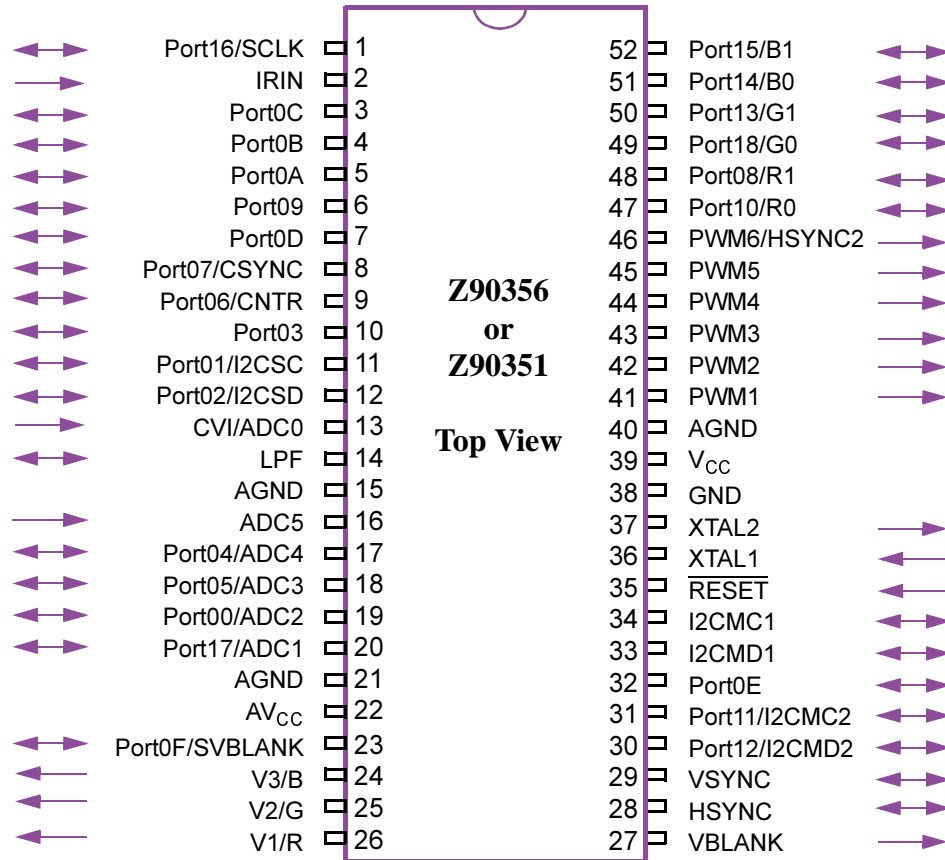

Figure 2 Block Diagram

## 1.2 Pin Description



**Figure 3 52-Pin SDIP Pinout**

**Table 1 Z90356 or Z90351 Pin Description**

Symbol	Pin #	Function	Direction
P16/SCLK	1	P16 or internal process SCLK	I/O
IRIN	2	Infrared remote capture input	I
P0C	3	Port 0, bit C	I/O
P0B	4	Port 0, bit B	I/O
P0A	5	Port 0, bit A	I/O



Table 1 Z90356 or Z90351 Pin Description (Continued)

Symbol	Pin #	Function	Direction
P09	6	Port 0, bit 9	I/O
P0D	7	Port 0, bit D	I/O
P07/CSYNC	8	P07 or composite sync output	I/O
P06/CNTR	9	P06 or counter input	I/O
P03	10	P03	I/O
P01/I <sup>2</sup> CSC	11	P01 or slave I <sup>2</sup> C clock I/O	I/O
P02/I <sup>2</sup> CSD	12	P02 or slave I <sup>2</sup> C data I/O	I/O
CVI/ADC0	13	ADC0 input or Composite Video Input	AI
LPF	14	Loop filter	AI/AO
AGND	15	Analog ground	Power
ADC5	16	ADC5 input	I
P04/ADC4	17	P04 or ADC4 input	I/O or AI
P05/ADC3	18	P05 or ADC3 input	I/O or AI
P00/ADC2	19	P00 or ADC2 input	I/O or AI
P17/ADC1	20	P17 or ADC1 input	I/O or AI
AGND	21	Analog ground	Power
AVCC	22	Analog +5V	Power
P0F/SVBLANK	23	P0F or OSD semi-transparency output	I/O
V3 (B)	24	OSD video output to drive Blue	O/AO
V2 (G)	25	OSD video output to drive Green	O/AO
V1 (R)	26	OSD video output to drive Red	O/AO
VBLANK	27	OSD overlay output	O
HSYNC	28	Horizontal sync	I/O
VSYNC	29	Vertical sync	I/O
P12/I <sup>2</sup> CMD2	30	P12 or master 2 I <sup>2</sup> C data I/O	I/O
P11/I <sup>2</sup> CMC2	31	P11 or master 2 I <sup>2</sup> C clock I/O	I/O
P0E	32	Port 0, bit E	I/O
I <sup>2</sup> CMD1	33	Master 1 I <sup>2</sup> C data I/O	I/O
I <sup>2</sup> CMC1	34	Master 1 I <sup>2</sup> C clock I/O	I/O



Table 1 Z90356 or Z90351 Pin Description (Continued)

Symbol	Pin #	Function	Direction
RESET	35	Reset	I
XTAL1	36	Crystal oscillator input	AI
XTAL2	37	Crystal oscillator output	AO
GND	38	Digital ground	Power
VCC	39	Digital Vcc	Power
AGND	40	Analog ground	Power
PWM1	41	8-bit PWM output	O
PWM2	42	8-bit PWM output	O
PWM3	43	8-bit PWM output	O
PWM4	44	8-bit PWM output	O
PWM5	45	8-bit PWM output	O
PWM6	46	8-bit PWM output/HSYNC2	I/O
P10/R0	47	P10 or output of RGB matrix	I/O
P08/R1	48	P08 or output of RGB matrix	I/O
P18/G0	49	P18 or output of RGB matrix	I/O
P13/G1	50	P13 or output of RGB matrix	I/O
P14/B0	51	P14 or output of RGB matrix	I/O
P15/B1	52	P15 or output of RGB matrix	I/O

## 2 Operation

### 2.1 CPU Descriptions

The Z89C00 core is a high-performance DSP that has a modified Harvard-type architecture with separate program and data memories. The design has been optimized for processing power and silicon space.

The Z89C00 used in the Z90356 device has been modified. The multiplier is disabled and is not accessible. However, the X and Y registers in the multiplier are still available and can be used as general-purpose registers. Refer to ZiLOG's Z89C00 documentation.



## **ALU**

The 24-bit ALU has two input ports, one of which is connected to the output of the 24-bit Accumulator. The other input is connected to the 24-bit P-Bus; the upper 16 bits are connected to the 16-bit D-Bus.

## **Instruction Timing**

Several instructions are executed in one machine cycle. Long immediate instructions and Jump or Call instructions are executed in two machine cycles. When the program memory is referenced in internal RAM indirect mode, it requires three machine cycles. An additional machine cycle is required if the PC is selected as the destination of a data transfer instruction. This only occurs with a register indirect branch instruction.

## **Hardware Stack**

A six-level hardware stack is connected to the D-Bus to hold subroutine return addresses or data. The CALL instruction pushes PC+2 onto the stack. The RET instruction returns the contents of the stack to the PC.

## **CPU Registers**

The Z90356 has 11 physical internal registers and four banks of eight external registers. In addition, it has nine virtual registers. The 11 internal registers are defined in Table 2, and the status register is defined in Table 3.

## **Internal Registers**

**Table 2 Internal Registers**

<b>Register</b>	<b>Register Definition</b>
X	X, 16 bits
Y	Y, 16 bits
A	Accumulator, 24 bits
SR	Status Register, 16 bits
Pn:b	Six RAM Address Pointers, 8 bits each
PC	Program Counter, 16 bits



**Table 3 Status Register**

Bit/Field	Bit Position	R/W	Description
N	15	R	ALU Negative
OV	14	R	ALU Overflow
Z	13	R	ALU Zero
L	12	R	Carry
Reserved	11	R	Reserved
Reserved	10	R	Reserved
Reserved	9	R	Reserved
OP	8	R/W	Overflow Protection
IE	7	R/W	Interrupt Enable
Register Bank Selector	6,5	R/W	00 Register Bank 0 01 Register Bank 1 10 Register Bank 2 11 Register Bank 3
SFD	4,3	R/W	“Short Form Direct” Bits
RPL	2-0	R/W	RAM Pointer Loop Size

**X** and **Y** are 16-bit general purpose registers.

**A** is a 24-bit Accumulator. The output of the ALU is sent to this register. When 16-bit data is transferred into this register, it goes into the 16 MSBs and the least significant eight bits are set to zero. Only the upper 16 bits are transferred to the destination register when the Accumulator is selected as a source register in transfer instruction.

**SR** is the Status Register that contains the ALU status and the control bits listed in Table 3. The status register is always read in its entirety. S15-S12 are set/reset by the hardware and can only be read through software. They are set or reset by the ALU after an operation.

S8-S0 can be written by software. S8, if 0 (reset), allows the hardware to overflow. If S8 is set, the hardware clamps at maximum positive or negative values instead of overflowing. S7 enables interrupts. S6–S5 are used for “short form direct” addresses, which are described below. The definitions of S2-S0 are listed in Table 4.



**Table 4 RPL Description**

S2	S1	S0	Loop Size
0	0	0	256
0	0	1	2
0	1	0	4
0	1	1	8
1	0	0	16
1	0	1	32
1	1	0	64
1	1	1	128

**Pn:b** are the pointer registers for accessing data RAM.

(n= 0, 1, 2 refer to the pointer number)

(b = 0, 1 refers to RAM bank 0 or 1).

They can be read from or written to directly and can point directly to locations in data RAM or indirectly to Program Memory.

**PC** is the Program Counter. When this register is assigned as a destination register, one NOP machine cycle is automatically added to adjust the pipeline timing.

### External Registers

The Z90356 module is capable of accessing eight external registers directly using only the three external register address signals that are normally available. Two user bits (Status register S6-S5) are combined with the register address signals to provide the ability to address four banks of eight registers each. The registers most critical for speed are located together in Bank 3. In this specification, all external registers are referred to as:

$$RX(Y) <Z>$$

where:

**X** is a register number within a register bank;

**Y** is a bank number; and

**Z** is a bit field number

An external register bank can be selected by setting bits 6 and 5 in the status register to define the bank, then specifying the address of the register on the external register address bus.

External registers reside on the chip and are used to control the operation of all the peripheral modules in the device. By reading or writing to the fields in the external registers, the user can interact with the peripheral devices on the chip.

### Virtual Registers

**BUS** is a read-only register that, when accessed, returns the contents of the D-Bus. It is a virtual register. (Physical RAM does not exist on the chip.)

**Dn:b** These eight data pointers refer to possible locations in RAM that can be used as pointers to locations in program memory. The programmer decides which location to choose two bits from in the status register and which two bits in the operand. This means only the lower 16 possible locations in RAM can be specified. At any one time there are eight usable pointers, four per bank, and the four pointers are in consecutive locations in RAM.

For example, if S3/S4 = 01 in the status register, then D0:0/D1:0/D2:0/D3:0 refers to locations 4/5/6/7 in RAM bank 0.

**Note:** When the data pointers are being written to, a number is actually being loaded to Data RAM, so they can be used as a limited method for writing to RAM.

### Additional Control Registers (AR)

Additional Control Registers (AR) control new peripheral blocks like palette banks and memory management. To activate ARs, R0(1)<b> must be set to “1.” ARs can be disabled by setting R0(1)<b> = 0, (POR) for software backward compatibility or if access to RAM location 1FFh is required.

The 128 eight-bit control registers (referred as AR or ARx<y:z>) use RAM-mapped I/O access. Location 1FFh in RAM is used to address up to 128 byte-width ARs. The AR number and written data are encoded into the data field as illustrated in Figure 4.

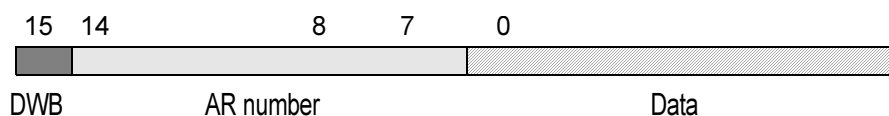

**Figure 4 AR Register Format**

When writing to address 1FFh, the Data Write Bit (DWB) and AR number are latched, depending on whether the DWB data field is either written to the selected port (latched) or discarded (not latched). The AR number and corresponding data are read after reading from the previously latched DWB address 1FFh.

To write to the AR, the data must be written to address 1FFh; DWB must be set to “1,” the port number must be specified in bits 8–14, and actual data must be specified in bits 0–7.



**Example**

```
LD    A, #(%8000 + 29*256 + %57); write 57 (hex) into the AR29
LD    %1FF, A;
```

**Note:** The DWB and port number are latched for further reading if necessary.

To read from the AR, the address must be previously latched by writing it to address 1FFh with DWB set to “0.” Bits 0–7 have no meaning. Because the bits are not going to be written in this mode, only the port number is latched.

**Example**

```
LD    A, #%1E00; latch AR30, data is not written
LD    %1FF, A;
LD    A, %1FF; read from AR30-%1EXX, where XX is current content
```

At least one cycle delay (NOP) is required between two consecutive accesses to the AR. If access is performed by a two-cycle instruction, no delay is necessary.

External memory must exhibit access times of less than 60 ns. Table 5 lists the additional control registers.

**Table 5 Additional Control Registers**

AR #	Name	Bit position	Data	Function
0	Palette_8	76----- --543210	%D %DD	Reserved Palette8/Color0—R1R0G1G0B1B0
1	Palette_8	76----- --543210	%D %DD	Reserved Palette8/Color1—R1R0G1G0B1B0
2	Palette_8	76----- --543210	%D %DD	Reserved Palette8/Color2—R1R0G1G0B1B0
3	Palette_8	76----- --543210	%D %DD	Reserved Palette8/Color3—R1R0G1G0B1B0
4	Palette_8	76----- --543210	%D %DD	Reserved Palette8/Color4—R1R0G1G0B1B0
5	Palette_8	76----- --543210	%D %DD	Reserved Palette8/Color5—R1R0G1G0B1B0
6	Palette_8	76----- --543210	%D %DD	Reserved Palette8/Color6—R1R0G1G0B1B0



**Table 5 Additional Control Registers (Continued)**

AR #	Name	Bit position	Data	Function
7	Palette_8	76----- --543210	%D %DD	Reserved Palette8/Color7—R1R0G1G0B1B0
8–15	Palette_9	76543210	%DD	Same as AR 0–7 for Palette9
16–23	Palette_10	76543210	%DD	Same as AR 0–7 for Palette10
24–31	Palette_11	76543210	%DD	Same as AR 0–7 for Palette11
32–39	Palette_12	76543210	%DD	Same as AR 0–7 for Palette12
40–47	Palette_13	76543210	%DD	Same as AR 0–7 for Palette13
48–55	Palette_14	76543210	%DD	Same as AR 0–7 for Palette14
56–63	Palette_15	76543210	%DD	Same as AR 0–7 for Palette15
64–123				Reserved
124	PgLocation0	7----- -6----- --543210	0 1 0 1 %DD	Page0 is located internally—POR Page0 is located externally Internal ROM is enabled—POR Internal ROM is disabled (low power consumption) Page0—external (physical) page number
125	PgLocation1	7----- -6----- --543210	0 1 0 1 %DD	Page1 is located internally—POR Page1 is located externally Reserved Page1—external (physical) page number
126	PgLocation2	76543210	%DD	Same as above for Page2
127	PgLocation3	76543210	%DD	Same as above for Page3

### RAM Addressing

The addresses in RAM can be specified in one of three ways. Refer to Figure 5.

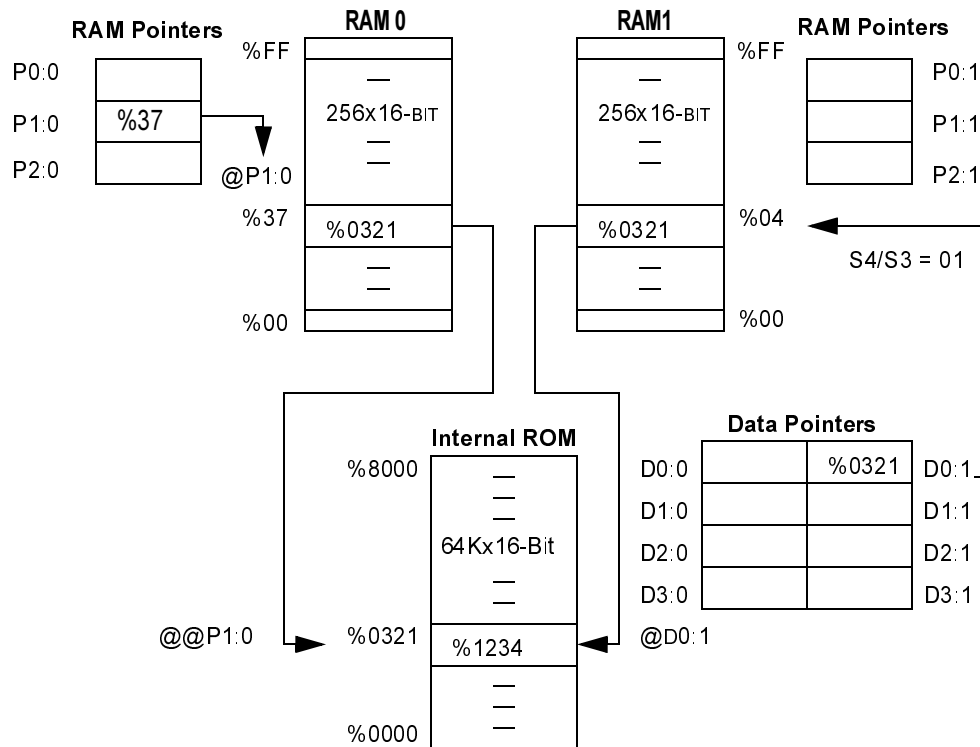

Figure 5 RAM, ROM, and Pointer Architecture

## 2.2 Memory (ROM and RAM)

The Z90356 has 64K words of Read Only Memory (ROM) and 1K words of Random Access Memory (RAM).

### ROM

The 64K words mask ROM is designed to provide storage for both program memory (PROGROM) and character set graphic pixel arrays (CGROM). The address boundary between these applications is dependent on the storage required for character graphics.

The program ROM section can, in theory, be accessed anywhere in the addressable ROM space; however, because CGROM usually starts at location 0000h, program ROM resides in the higher address locations. The maximum available ROM space for program memory depends on the ROM reserved for CGROM (for an application) and the ROM size of the device selected.



CGROM can be placed anywhere in the 64K ROM address space by setting the CGROM address offset register R7(2). This offset is added to the character address before accessing ROM. By modifying the CGROM offset, several fonts can be accessed (limited by ROM size only). When reset, R7(2) =0 (no offset) for backward compatibility with existing software. Refer to Figure 6.

64K	Int0 vector	%FFFF
	Int1 vector	%FFFE
	Int2 vector	%FFFD
	Reset vector	%FFFC
	Program ROM or CGROM	
Up to 5K	CGROM—Bank 0, Scan lines 19, 20 or Bank1 or Program ROM	%1400
Up to 4.5K	CGROM—Bank 0, Scan lines 17, 18 or Bank 1, or Program ROM	%1200
4K	CGROM—Bank 0, Scan lines 17, 18 or Bank 1, or Program ROM	%1000
Up to 4K	Program ROM	%10*n
	CGROM-Bank 0 (n Characters) Scan lines 1-16	%0000

Figure 6 ROM Map

## RAM

The 1K words RAM is organized in four banks of 256 words consisting of 16 bits each. Bank1.0 is always accessible. Bank0.0 is mapped to other bank(s); only one gauge from 0.X is active through bit selection. See Figure 7.

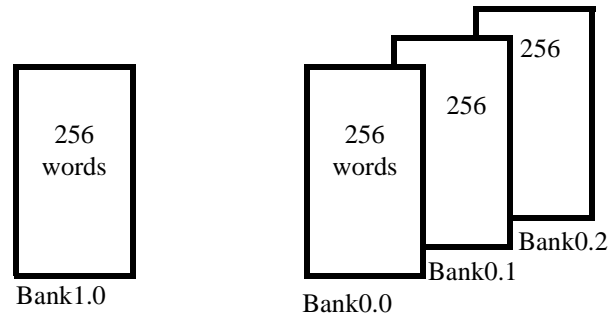

**Figure 7 RAM Allocation**

## 2.3 Clock Circuit Description

The processor is able to operate from several clock sources:

- Primary Phase Lock Loop VCO source (PVCO)
- Secondary Phase Lock Loop (SVCO)
- 32.768-kHz oscillator clock (OSC)

In addition, the processor clock can be halted temporarily to select the clock source or access ROM without disrupting normal operation of the processor.

An external crystal controls the internal 32.768-kHz oscillator. The crystal is used as the clock reference for the internal Phase Locked Loop (PLL). The PLL provides the internal PVCO clock for processor operation. SCLK is generated internally by dividing the frequency of an appropriate oscillator (PVCO) by 2. The frequency of the SCLK after POR is 12.058 MHz.

The SCLK signal can be sent to the Port16 output pin under software control by setting bit 9 in register R3(1). The SVCO must be used as the system clock when the OSD is generated.

The clock switch control register R6(1) defines the source of the SCLK for the Z90356 core. The block diagram in Figure 8 represents the clock switch circuit.

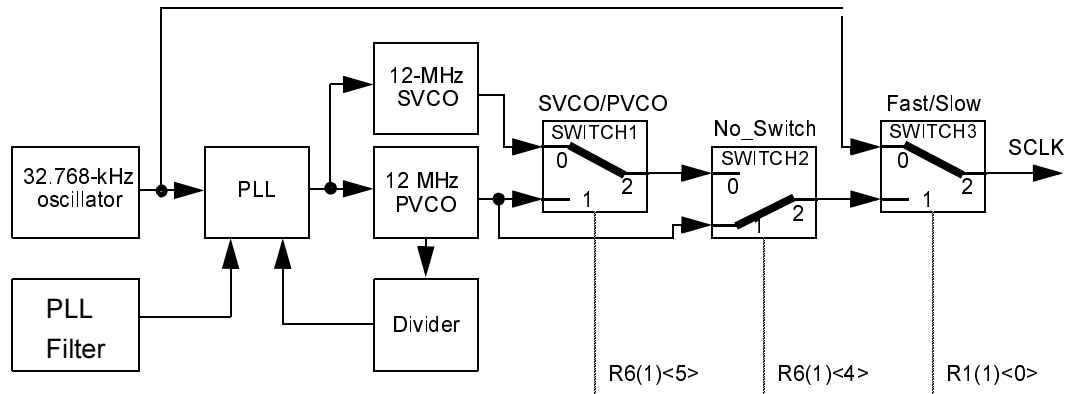

Figure 8 Clock Switching Block Diagram

### Input/Drive Circuits

The 32-KHz oscillator circuit in Figure 9 is suggested for proper clock operation.

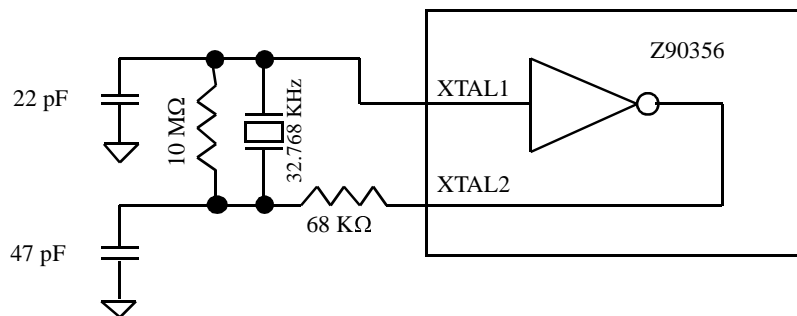

Figure 9 32-KHz Oscillator Recommended Circuit



## 2.4 Reset Conditions

Reset conditions including addresses and registers are listed in Table 6.

**Table 6 Reset Conditions**

Addr	Register	-----Reset Condition-----														Comments		
		15	14	13	12	11	10	9	8	7	6	5	4	3	2		1	0
R0(0)	reserved	x	x	x	x	x	x	x	x	x	x	x	x	x	x	x	x	Not available
R1(0)	Cursor Palette	x	x	0	0	x	x	x	x	x	x	x	x	x	x	x	x	Cursor palette gauge
R2(0)	pll_freq	0	0	1	0	0	0	0	0	x	x	x	x	x	x	x	PLL frequency control	
R3(0)	I <sup>2</sup> C_int	0	0	0	0	0	x	x	x	x	x	x	x	x	x	x	I <sup>2</sup> C interface register	
R4(0)	port0	x	x	x	x	x	x	x	x	x	x	x	x	x	x	x	16-bit I/O port 0	
R5(0)	port1	x	x	x	x	x	x	x	x	x	x	x	x	x	x	x	9-bit I/O port 1	
R6(0)	dir0	1	1	1	1	1	1	1	1	1	1	1	1	1	1	1	16-bit port 0 direction	
R7(0)	dir1	x	x	x	x	x	x	1	1	1	1	1	1	1	1	1	9-bit port 1 direction	
R0(1)	clamp_pos	1	1	1	1	0	0	0	0	0	x	x	x	x	x	x	Position of video clamp pulse	
R1(1)	sclk_freq	x	0	0	0	0	0	0	0	0	x	x	x	0	0	0	Stop/sleep/normal mode	
R2(1)	9-bit cntr	x	x	x	x	x	x	x	x	x	0	0	0	0	0	0	Stop and WDT, 9-bit counter	
R3(1)	standard_ctl	0	0	0	0	0	0	0	0	0	0	0	x	x	x	0	Output H/VSYNC/ Blink Control	
R4(1)	ADC_ctl	0	0	0	0	0	0	0	0	0	0	0	0	x	x	x	A/D converter control	
R5(1)	cap_1s_ctl	x	x	x	x	0	0	x	x	x	x	x	x	x	x	x	Counter timers control	
R6(1)	clock_ctl	0	0	0	0	0	0	0	0	0	0	x	1	x	x	x	Clock control (switch VCO/DOT)	
R7(1)	wdt_smr_ctl	x	x	x	x	x	x	x	x	0	x	x	x	x	x	x	SMR and WDT control/interrupt	



**Table 6 Reset Conditions (Continued)**

R0(2)	pwm_data1	0	0	0	0	0	0	0	0	x	x	x	x	x	x	x	x	8-bit PWM 1 data
R1(2)	pwm_data2	0	0	0	0	0	0	0	0	x	x	x	x	x	x	x	x	8-bit PWM 2 data
R2(2)	pwm_data3	0	0	0	0	0	0	0	0	x	x	x	x	x	x	x	x	8-bit PWM 3 data
R3(2)	pwm_data4	0	0	0	0	0	0	0	0	x	x	x	x	x	x	x	x	8-bit PWM 4 data
R4(2)	pwm_data5	0	0	0	0	0	0	0	0	x	x	x	x	x	x	x	x	8-bit PWM 5 data
R5(2)	pwm_data6	0	0	0	0	0	0	0	0	x	x	x	x	x	x	x	x	8-bit PWM 6 data
R6(2)	Shadow Ctrl	0	0	0	0	0	0	0	0	x	x	x	x	x	x	x	x	Shadow color ctrl
R7(2)	CGROM offset	0	0	0	0	0	0	0	0	0	0	0	0	0	0	0	0	CGROM offset register
R0(3)	hi_x2_hi_x3	x	x	x	x	x	x	x	x	x	x	x	x	x	x	x	x	Character multiple/current data
R1(3)	lo_x2_mid_x3	x	x	x	x	x	x	x	x	x	x	x	x	x	x	x	x	Character multiple/next or previous data
R2(3)	Ch_x1_lo_x3	x	x	x	x	x	x	x	x	x	x	x	x	x	x	x	x	Character multiple/character graphics attribute
R3(3)	attr_data	x	x	x	x	x	x	x	x	x	x	x	x	x	x	x	x	Character attribute/video RAM data
R4(3)	osd_cntl	x	x	x	x	x	x	x	x	x	x	x	x	x	x	x	x	On screen display control
R5(3)	cap_data	x	x	x	x	x	x	x	x	x	x	x	x	x	x	x	x	Capture register data
R6(3)	palette_color	0	0	0	0	0	0	0	0	0	0	0	0	0	0	0	0	Display palette color/underline color
R7(3)	output palette	0	0	0	0	0	0	0	0	0	0	0	0	0	0	0	0	Output palette



## **2.5 Power Management**

There are two low-power operating modes for Z90356: SLEEP mode and STOP mode.

### **SLEEP Mode**

In SLEEP mode, the controller uses the 32.768-KHz clock for the SCLK to reduce power consumption.

### **STOP Mode**

In STOP mode, the processor is suspended, and the power consumption is minimized.

## **2.6 I/O Port Configurations**

User control can be monitored either through the keypad scanning port or the 16-bit remote control capture register.

Two input/output port blocks are available for general-purpose digital I/O application. Each port bit can be programmed to be either an input or output port. To conserve the device pin count, some port pins are mapped to provide I/O to the ADC converter block and I<sup>2</sup>C interface block.

The 25 configurable I/O pins are general-purpose pins for functions such as serial data I/O, LED control, key scanning, power control and monitoring, and I<sup>2</sup>C serial data communications.

Port 0 and 1 directions are defined in R6(0) and R7(0), respectively. R4(0) and R5(0) are data registers for both Ports 0 and 1. Figure 10, Figure 11, and Figure 12 indicate I/O configuration and sharing with other functional units.

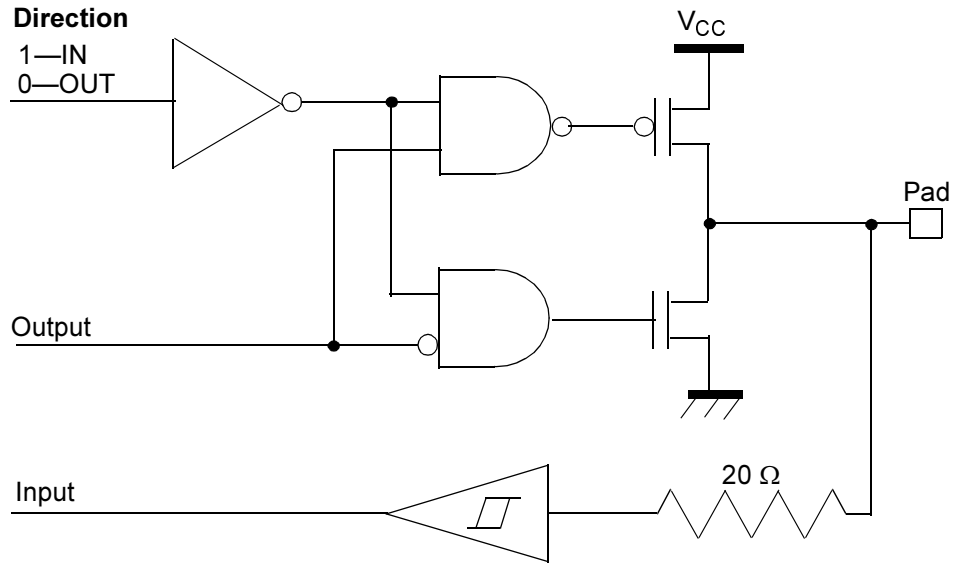

Figure 10 Bidirectional Port Pins

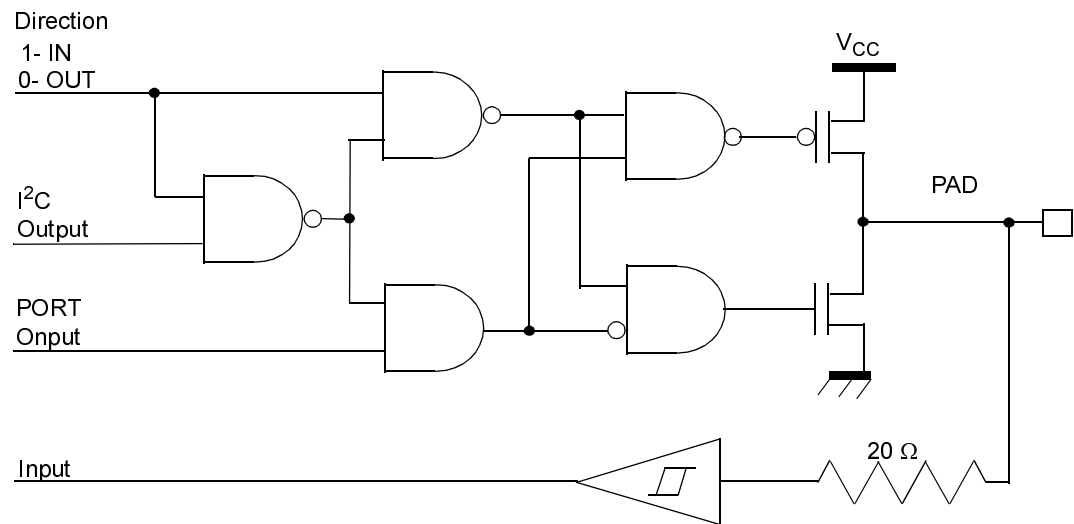

Figure 11 Bidirectional Pins Multiplexed with I2C Port

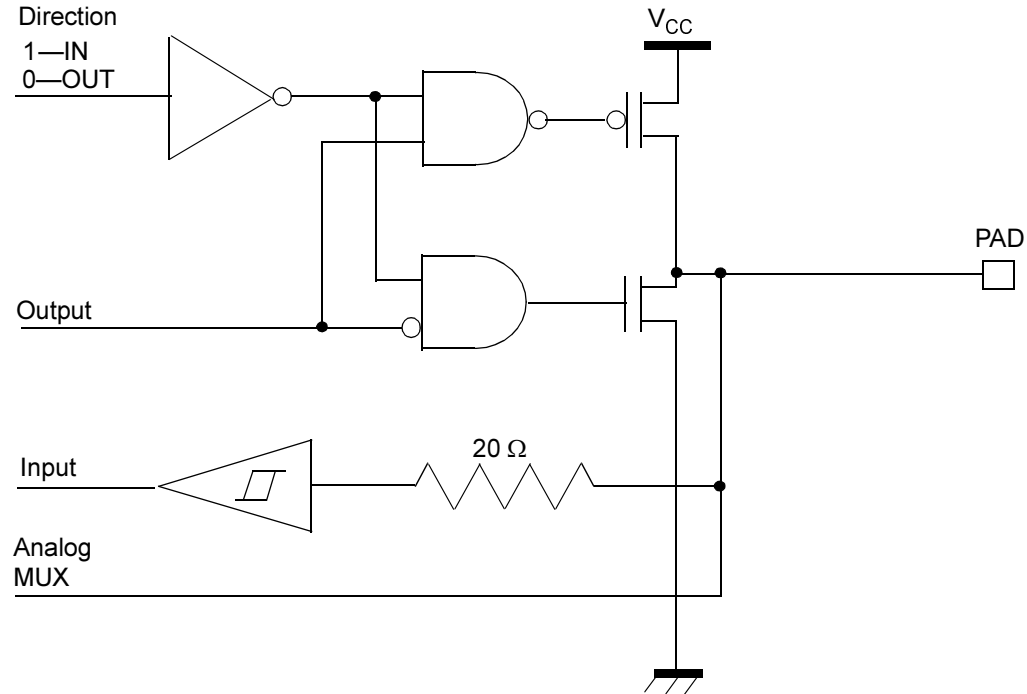

Figure 12 Bidirectional Pins Multiplexed with ADC Inputs

## 2.7 Interrupts

The Z90356 has three external interrupt signals. There are four interrupt sources as follows:

- Horizontal sync ( $H_{SYNC}$ )
- Vertical sync ( $V_{SYNC}$ )
- Capture timer
- External event (Port09).

All interrupts are vectored. The capture timer and Port09 are multiplexed to the same interrupt.

Interrupt priorities are programmable. Each interrupt can be masked by setting fields in the external registers.

When the Z90356 receives an interrupt request from one of the interrupt sources, it executes the interrupt service routine directly for that source.

External register R7 (1) controls interrupts.

## 2.8 Timers

### Watch-Dog Timer

The watch-dog timer resets the CPU when it times out.

External register R7 ( 1 ) controls the watch-dog timer.

### Real Time Clock

A clock timer, in real time, generates ticks every 1000, 250, 62.5 or 15.625 ms. External register R5 ( 1 ) controls the real time clock.

### IR Capture Timer

A capture timer measures time between edges of the IR signal. This timer can be programmed to measure timing from rising-to-rising, falling-to-rising, rising-to-falling, or falling-to-falling edges.

The IR capture timer is controlled by External register R5 ( 1 ) . Figure 13 is a block diagram of the IR capture register structure.

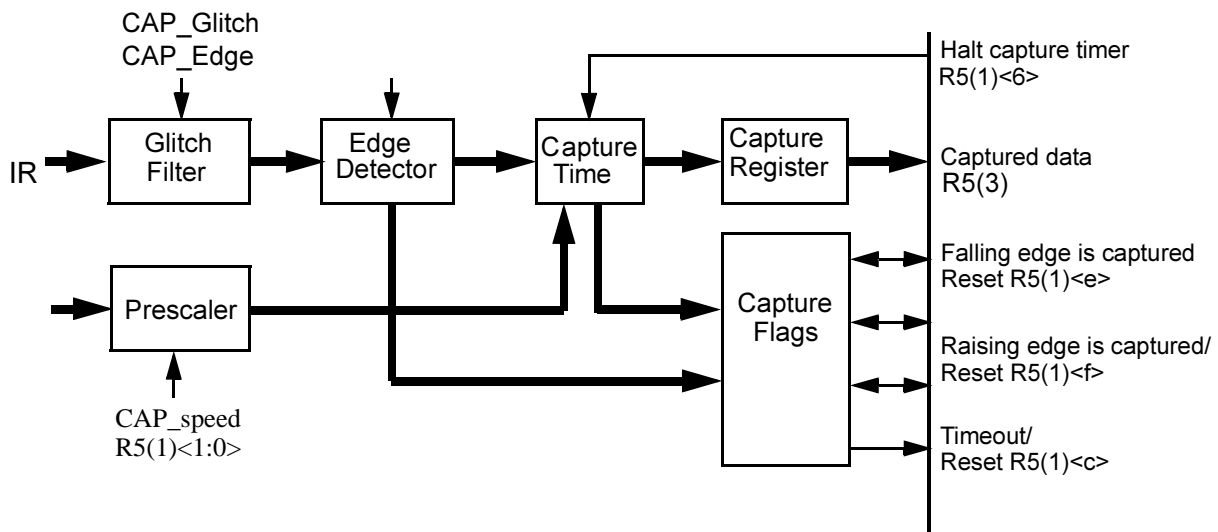

Figure 13 IR Capture Register Block Diagram

## 2.9 ADC

This function employs a 4-bit resolution, flash A-to-D converter. The six-to-one analog input multiplexor and conversion start circuits are controlled by the user program. The 4-bit conversion result is available to be read by the CPU at the end of each conversion.

One input channel (ADC0) is dedicated for quantizing VBI (vertical blank interval) data for subsequent digital signal processing. Another channel, ADC5, is typically used for VSYNC separation from the composite TV signal. These channels (ADC0 and ADC5) feature a special video clamp circuit that provides DC restoration of the composite video input signal. Typical VBI applications include Line 21 Closed Caption, Electronic Data Services, and StarSight Telecast. The range of ADC0 and ADC5 is from 1.5 to 2.0 V.

The four remaining channels of ADC (ADC1, ADC2, ADC3, and ADC4) are general purpose. They are typically used for tuner automatic frequency control and analog key entry. The range of ADC1–ADC4 is from 0 to 5.0 V.

The 4-bit ADC in the Z90356 features six multiplexed inputs.

The allowed range of the input signals is different for different ADC inputs according to Table 7.

**Table 7 ADC Inputs Typical Range**

Input	Range (V)	Clamping	Typical application
CVI/ADC0	1.5–2.0	Yes (Ref–)	CCD sampling input
ADC1/P17	0–5.0	No	AFC input
ADC2/P00	0–5.0	No	Front-panel control button
ADC3/P05	0–5.0	No	Front-panel control button
ADC4/P04	0–5.0	No	Front-panel control button
ADC5	1.5–2.0	Yes (Ref+)	VSYNC decoder sampling input

Reference voltages that have been generated internally define the maximum range of the input signal for the ADC.

Nominal values are as follows:

$$\text{Ref+} = 2.0 \text{ V}$$

$$\text{Ref-} = 1.5 \text{ V @ } V_{CC} = 5.0 \text{ V}$$

For other  $V_{CC}$  values, the reference voltages must be prorated as follows:

$$\text{Ref+} = 0.4 * V_{CC}$$

$$\text{Ref-} = 0.3 * V_{CC}$$

The maximum sampling rate of the ADC converter is 3 MHz. It takes 4 SCLK cycles for valid output data from the ADC to become available. This is especially important if the application uses the single-shot mode.

The ADC exhibits monotonous conversion characteristics with a nonlinearity of less than 0.5 LSB. ADC0. The ADC has a range of 0.5V (from 1.5V to 2.0V) and is directly multiplexed to the input of the ADC. The remaining ADC inputs (ranging from 0V to 5V) use AGND and AV<sub>CC</sub> voltage as a reference.

Figure 14 is a block diagram of the ADC inner structure, and Figure 15 illustrates ADC input circuits.

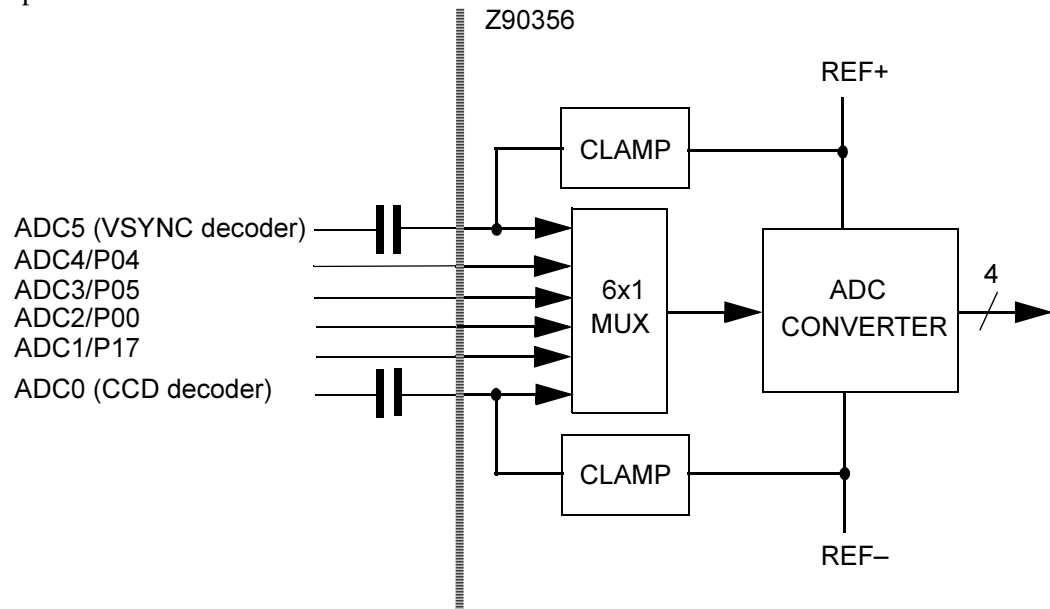

**Figure 14 ADC Block Diagram**

### ADC Data Packing

Up to four 4-bit ADC data samples can be packed into one 16-bit word without software overhead. If R4(1)<9> = 1, every reading of R4(1) returns the result, where the High 12 bits are the three previous ADC samples and the Low 4 bits are the current one, as illustrated in Figure 15.

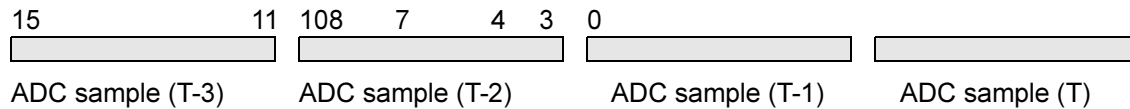

**Figure 15 ADC Data Packing**

NOPs between ADC accesses are omitted.

```
LD SR,%#20; select RegBank1
LD A,EXT4; turn "ADC data packing" mode on
OR A, %#0200;
LD EXT4, A;
LD A, EXT4; read first ADC sample, A = %0005
LD A, EXT4; read second ADC sample, A = %005E
LD A, EXT4; read third ADC sample, A = %05E7
LD A, EXT4; read fourth ADC sample, A= %5E74
LD A, EXT4; read fifth ADC sample, first sample is thrown away, A = %E741
```

The ADC is controlled by the external register R4(1).

## 2.10 Pulse Width Modulation

Pulse Width Modulation is used in conjunction with external low-pass filters to perform digital-to-analog conversion. Six PWMs (8-bit resolution each) generate signals for the control of video and sound attributes. In case of a chassis employing a frequency synthesis tuner, these PWMs can also control video or sound attributes.

Each PWM circuit features a data register whose contents are set under program control. The data in the register determines the ratio of PWM High to PWM Low time. PWM data registers are not initialized when reset. In order to eliminate a potential glitch on a PWM output, it is recommended to initialize PWM data registers before enabling the VCOs.

External registers R0(2) to R5(2) are data registers for PWM1 to PWM6 accordingly.

## 2.11 I<sup>2</sup>C Interface

There are two hardware modules that support standard I<sup>2</sup>C bus protocol according to the I<sup>2</sup>C bus specification published by Phillips in 1992, entitled *I<sup>2</sup>C Peripherals for Microcontrollers Data Handbook*.



The first module, the Master, can be configured for fast (400 kHz) or slow (100 kHz) bit rates and can be used in applications with a single master.

The second module, the Slave, supports a 7-bit addressing format with both fast and slow bit rates.

The Z90356 adds two additional nonstandard bit rates (50 kHz and 10 kHz) and an additional multiplexed master port that is controlled by the I<sup>2</sup>CM\_mux control bit.

Table 8 lists the bit rates for the Master I<sup>2</sup>C Bus.

**Table 8 Master I<sup>2</sup>C Bus Bit Rates**

Mode	I <sup>2</sup> C mode	Bit Rate	Actual Bit Rate
LO/Slow	—	0–10 kHz	10 kHz
HI/Slow	—	0–50 kHz	44 kHz
LO/Fast	Slow	0–100 kHz	91 kHz
HI/Fast	Fast	0–400 kHz	334 kHz

To suppress possible problems on both data (SDA) and clock (SCL) lines, digital filters are available for all inputs of the I<sup>2</sup>C bus interface. These filters exhibit a time constant equal to  $3T_{SCLK} = 250$  ns.

If the Master or Slave I<sup>2</sup>C interface is enabled, corresponding I/Os (Port01 and Port02 for the slave, Port11 and Port12 for the master) must be assigned as outputs.

Master and Slave modules cannot be used simultaneously because of the shared I<sup>2</sup>C data register (see the register R3(0) data field). The software activates I<sup>2</sup>C modules by writing appropriate commands into the control register. To control the I<sup>2</sup>C bus interface, the control register R3(0) toggle bit <c> must point to an appropriate interface (Master or Slave).

**M\_disable** or **S\_disable** bits allow either the Master or Slave I<sup>2</sup>C interface to be disabled so as not to interfere with any activity associated with the Port pins. At Power-on Reset (POR), both I<sup>2</sup>C interfaces are enabled. To use the I<sup>2</sup>C interface, the corresponding Port pin (multiplexed with the I<sup>2</sup>C Data and Clock) must be configured as an output, while M\_disable or S\_disable bits must be reset to 0.

External register R3(0) controls the I<sup>2</sup>C. Table 9 lists the Master I<sup>2</sup>C bus interface commands. Table 10 lists the Slave I<sup>2</sup>C bus interface commands. Figure 16 and Figure 17 are flow charts of the Master and Slave modes.



**Table 9 Master I<sup>2</sup>C Bus Interface Commands**

Command	Notes/Function
0 0 0	This command sends a start bit, followed by an address byte specified in the “data” field (bits <7:0>), then fetches an acknowledgment in bit <0>. This command initializes communication and generates 9 SCL cycles.
0 0 1	This command sends one byte of data specified in the “data” field (bits <7:0>), then fetches an acknowledgment in bit <0>. This command is used in a WRITE frame and generates 9 SCL cycles.
0 1 0	This command sends bit <7> as an acknowledgment (ACK = 0, NAK = 1), then receives a data byte. This command is used in a READ frame when the next data byte is expected and generates 9 SCL cycles. Received data appears in the “data” field (bits <7:0>).
0 1 1	This command sends bit <7> as an acknowledgment (ACK = 0, NAK = 1). This command is used in a READ frame to terminate data transfer and generates one SCL cycle.
1 0 0 1 0 1	A NULL operation. This command must be used with a “RESET” bit <b> and/or a “TOGGLE” bit <c>. Using the “RESET” and/or “TOGGLE” bits with any other command interferes with the logic of the I <sup>2</sup> C interface.
1 1 0	This command receives one data byte. It is used in a READ frame to receive the first data byte after the address byte is transmitted. It generates 8 SCL cycles.
1 1 1	This command sends a stop bit and generates one SCL cycle.



**Table 10 Slave I<sup>2</sup>C Bus Interface Commands**

Command	Notes/Function
0 0 0	Reserved. Cannot be used.
0 0 1	This command sends bit <7> as an acknowledgment (ACK = 0 only), then receives one data byte. This command is used in a WRITE frame and requires 9 SCL cycles. Received data is read as a “data” field (bits <7:0>).
0 1 0	This command sends one byte of data specified in a “data” field (bits <7:0>), then fetches an acknowledgment in bit <0>. This command is used in a READ frame and requires 9 SCL cycles.
0 1 1	Reserved. Cannot be used.
1 0 0 1 0 1	A NULL operation. This command must be used with a “RESET” bit <b> and/or “TOGGLE” bit <c>. Using the “RESET” and/or “TOGGLE” bits with any other command interferes with the logic of the I <sup>2</sup> C interface.
1 1 0	This command sends a bit <7> as a not acknowledgment (NAK = 1 only) in a WRITE or READ frame. This command terminates I <sup>2</sup> C communication and requires one SCL cycle. The “Sulfanilamide” bit <a> is automatically reset when a “busy” bit <9> goes Low. This command sends a bit <7> as an acknowledgment (ACK = 0 only) in a READ frame and requires one SCL cycle. The Send data command (010) must be executed next. This command acknowledges an address byte in a READ frame.
1 1 1	Reserved. Cannot be used.

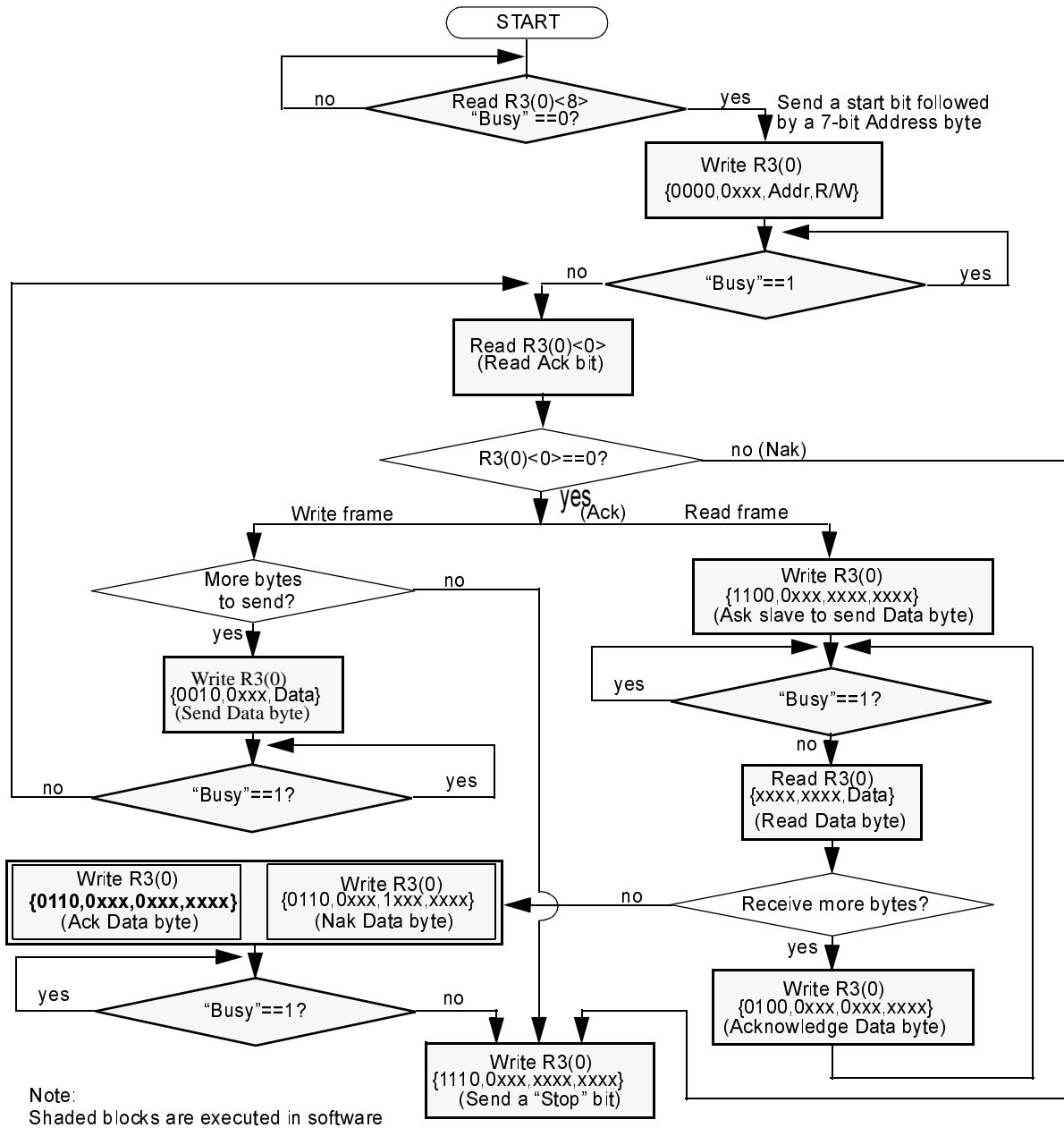
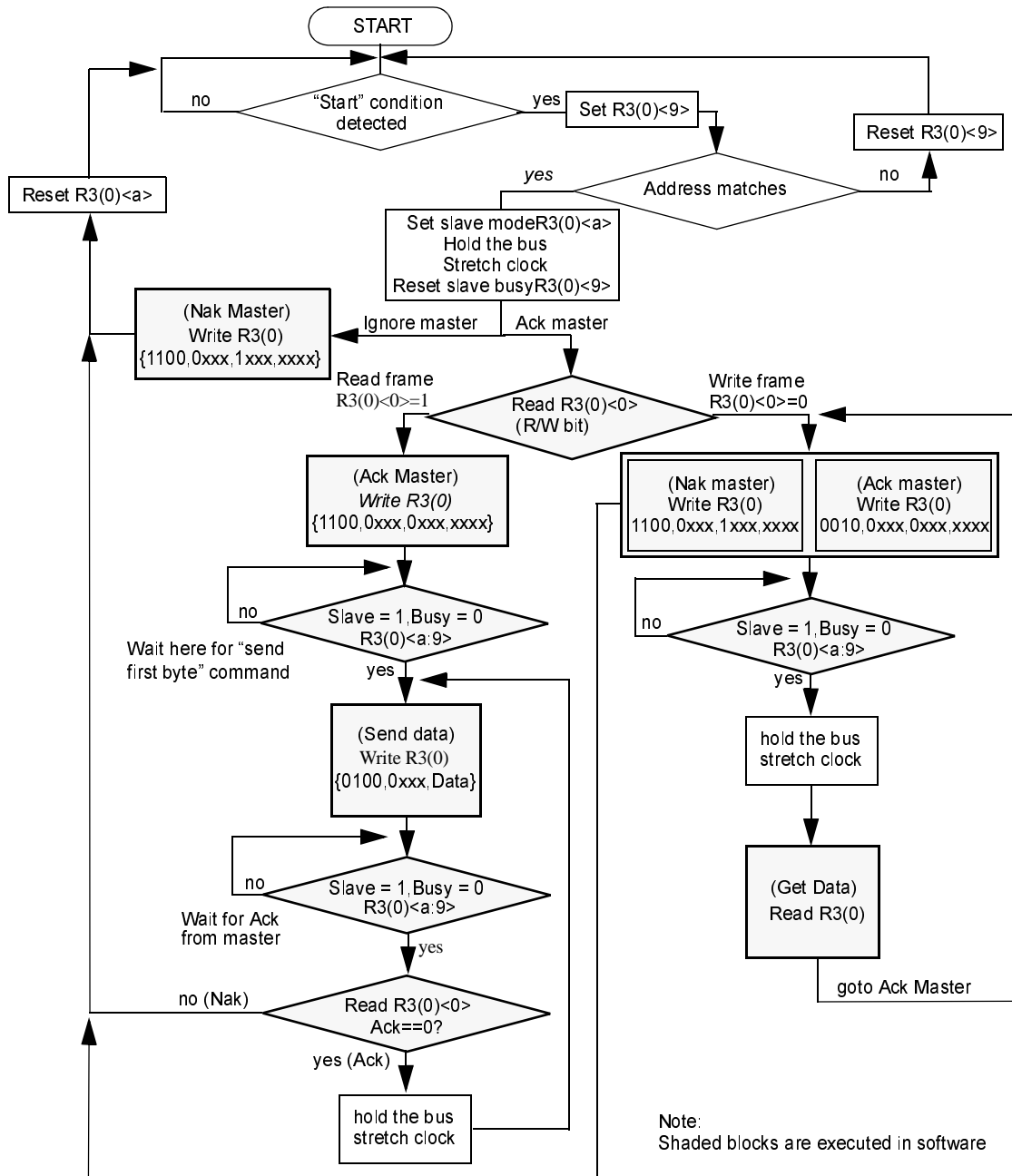

Figure 16 Master Mode



**Note:** If a “Stop” condition is detected at any point, the hardware resets the “Slave” bit (R3(0)<a>) and releases the I<sup>2</sup>C bus.

**Figure 17 Slave Mode**



## **2.12 On-Screen Display (OSD)**

The Z90356 provides sophisticated on-screen display features. On-Screen Display has the following two modes:

- **OSD** Used to generate TV control OSD
- **CCD** Used to display Closed Caption information

OSD mode provides access to the full set of control attributes including latched and unlatched attributes. Unlatched attributes can be modified on a character-by-character basis. Control characters change latched attributes.

Any 256-character set can be displayed with many display attributes, including underlining, italics, blinking, eight foreground and background colors, character position offset delay, and background transparency. A 16-bit display character represents foreground color, background color, and underline attributes, which can be modified character by character. In addition, the Z90351 supports eight fixed plus eight programmable color palettes out of 64 colors, independent left and right shadows with color control. Shadows are available on transparent and nontransparent backgrounds. Semitransparency is supported on a character-by-character basis. A character's pixel array is stored as 16, 18, or 20 words in Character Generation ROM (CGROM).

Additional hardware provides the capability to display characters at two and three times normal size. The smoothing logic contained in the on-screen display improves the appearance of two and three times normal size characters. Shadows can be activated to improve the visibility of characters by adding a border (one pixel wide) on each side.

The Z90351 provides RGB signals and video blank signal. RGB outputs are available in two modes: digital and analog. In digital mode, the output RGB signals correspond to a primary colors palette. Analog mode supports 16 different palettes, which can be chosen under software control. In analog mode, each RGB output is generated by a 2-bit digital-to-analog converter. The user can switch the 2-bit digital inputs of the digital-to-analog converter to Port pins (P10, P13, P14, P15, P18 and P08) under software control by setting a bit in the control register.

Video synchronization is normally obtained from H\_FLYBACK and V\_FLYBACK but can be generated by the Z90356 and driven to the external deflection unit using the bidirectional SYNC ports when external video synchronization signals are not present.

OSD is completely software controlled. Hardware supports the optimum generation of the character-based OS; however, the CPU can bypass it and generate pixels and attributes directly. The block diagram in Figure 18 illustrates the OSD data flow.

Figure 19 and Figure 20 indicate the V1, V2, V3, and Blank output circuits.

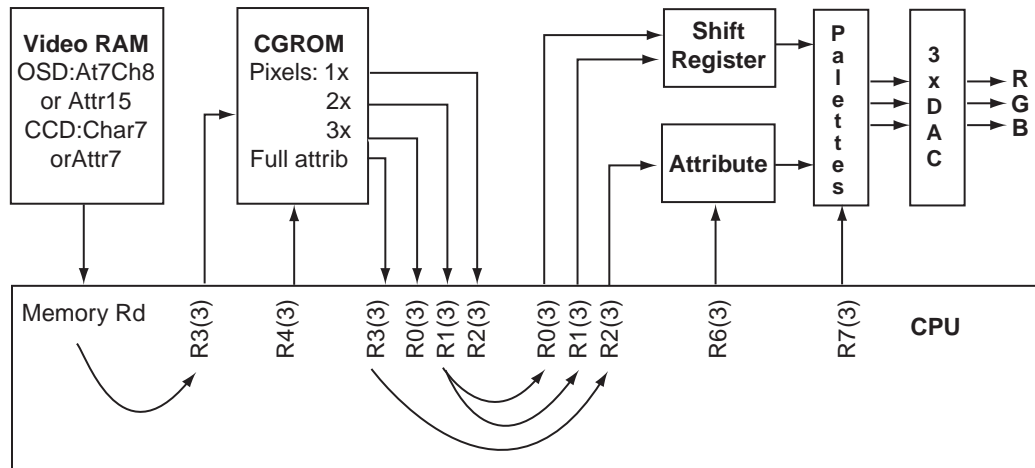

Figure 18 Data Flow

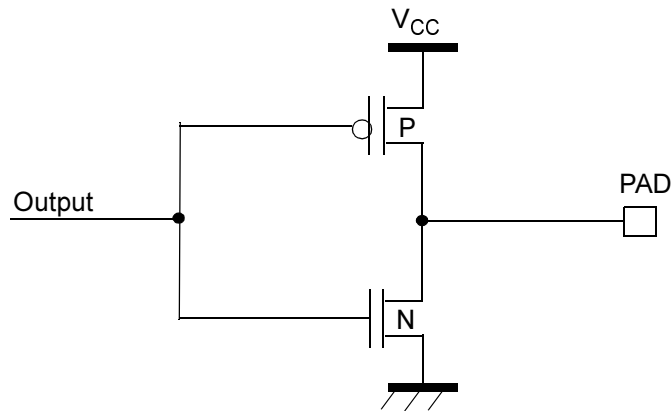

Figure 19 Blank and V1, V2, V3 Outputs in Digital Mode

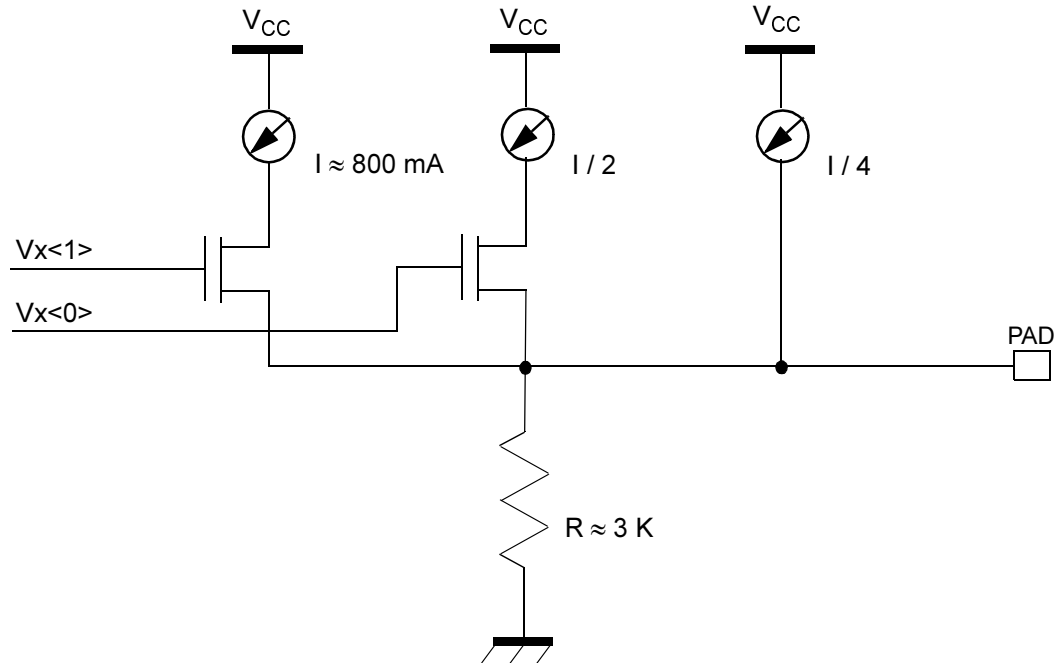

Figure 20 V1, V2, and V3 Outputs in Analog (Palette) Mode

### Closed Caption Data Capture

Closed-caption text can be decoded directly from the composite video signal using the processor's digital signal processing capabilities and displayed on the screen. The character representation in this mode provides simple attribute control by inserting control characters. Each word of video RAM specifies two displayed characters.

The 4-bit flash A/D converter, with proper clamping, provides the ability to receive the composite video signal directly and process the closed-caption text embedded in the signal. Signal processing can be applied directly to the signal to improve decoder performance.

### CGROM Relocation

CGROM can be placed anywhere in the 64K ROM address space by setting the CGROM address offset register R7(2). This offset is added to the CGROM address before accessing the ROM. By modifying the CGROM offset, several fonts can be accessed (limited only by ROM size). When reset, R7(2) = 0 (no offset), making the Z90351 backward-compatible with existing OSD control software.

The character scan line from CGROM addressed by the character register is fetched and stored into the CGROM capture register. If a pixel is set to 1, it displays the foreground color. If a pixel is set to 0, it displays the background color. The scan line can be stretched by the character multiplier to be two or three times normal character size by duplicating each bit in the word.

### Controlling Character Expansion

The character size can be stretched to two or three times its size the size of the scan line. Hardware fetches data from CGROM and stretches the data to be read from registers R0(3), R1(3), and R2(3). Figure 21 is a block diagram of the structure of the character expansion multiplexor, and Table 11 lists bit functions.

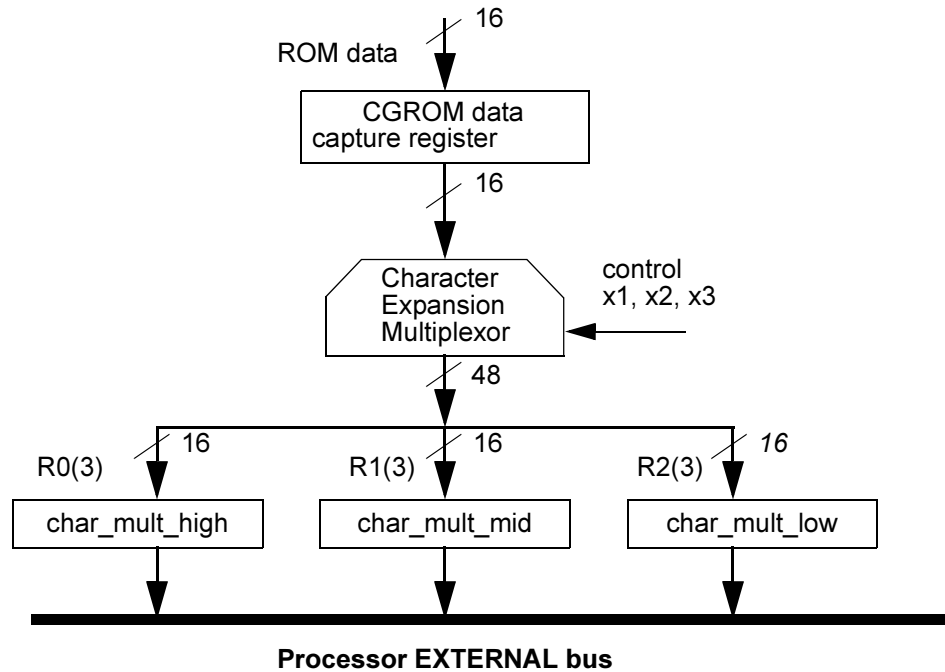

Figure 21 Character Expansion

Table 11 Character Expansion Register

Capture Register Contents	Char_mult_high	Char_mult_mid	Char_mult_low
x1 operation	abcdefghijklmnop		
x2 operation	aabbccddeeffgghh	ijjkkllmmnoopp	



**Table 11 Character Expansion Register (Continued)**

Capture Register Contents	Char_mult_high	Char_mult_mid	Char_mult_low
x3 operation	aaabbbcccddeef	ffggghhhiiijjkk	kl11mmnnnoopp

**Displayed Data Formats**

The Z90356 hardware supports the following two different data formats:

- **OSD mode, R4(3)<d> = 1** supports a standard OSD with full set of features.
- **CCD mode, R4(3)<d> = 0** supports reduced features which comply with the recommendations of the FCC on Closed Caption support.

In CCD mode, the background color of the characters *cannot* be changed and is always preset to BLACK.

**OSD Mode**

In OSD mode, each character occupies a 16-bit word in VRAM. There are two possible character formats defined: a “display” character and a “control” character. The code stored in “display” character format defines a character code and up to 7 attributes of the character.

The “control” character defines latched attributes and is presented on-screen as a space character. The combination of “display” and “control” characters provides versatile OSD generation.

Smoothing is supported for double-size (x2) and triple-size (x3) characters only.

**CCD Mode**

In CCD mode, each character occupies 8 bits (one byte) in VRAM. The CCD characters must be mapped into a 16-bit VRAM data field. The hardware supports compressed placement of characters in VRAM. Each word in VRAM is represented by a High byte and a Low byte. A currently active byte is selected by R4(3)<c>. The format and data representation in both bytes is exactly the same.

There are two possible character formats defined: a “display” character and a “control” character. The code stored in “display” character format defines a character code. The “control” character defines up to five attributes (foreground color, italic, underline, blinking, and transparent). It is presented on screen as a space character. The combination of Display and Control characters provides the basis for a specified range of attributes defined by FCC specifications for CCD.

## Shadows

Shadows, if enabled, are active on both transparent and nontransparent backgrounds. Two bits in the AttributeWR and AttributeRD registers (R2(3)<1:0> and R3(3)<1:0>) control the type of shadow. Refer to Figure 22.

R2(3)<1:0>, R3(3)<1:0>	Function
00	No shadows
01	Left shadow
10	Right shadow
11	Both shadows (fringing)

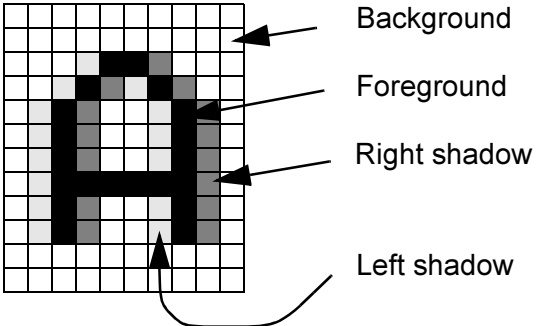

The diagram shows a 16x16 grid with a character 'H' in the center. The background is white. The foreground is black. The right shadow is a gray area to the right of the 'H'. The left shadow is a gray area to the left of the 'H'. Arrows point from labels to these areas: 'Background' points to the white area, 'Foreground' points to the black 'H', 'Right shadow' points to the gray area on the right, and 'Left shadow' points to the gray area on the left.

**Figure 22 Table Settings**

The smoothing attribute has been moved to R7(3)<5>.

The bit assignment in the Latched Attribute follows the bit assignment in R2(3).

The left and right shadow colors are independently controlled by R6(2)<d:b> and R6(2)<a:8>.

**Note:** The smoothing control bit R7(3)<5> must be set to a “1” in order to activate fringing.

## Semi-Transparent

Both semi-transparency (pin name SOVL) and transparency (pin name OVL) attributes are supported. The semi-transparency mode can be enabled through either latched or unlatched attributes. Latched attributes remain set until they are reset. Unlatched attributes remain set for only one character, which means the attribute must be constantly refreshed on a character-by-character basis.

## Activation

To activate semi-transparency output, two bits must be set properly. Port 0F must be in output mode [R6(0)<f> = 0], and the SOVL/port0F control bit must be in SOVL mode [R3(1)<6> = 1].

## Latched Semi-Transparency

The latched semi-transparency attribute is controlled by bit [R2(3)<6>].

### Unlatched Semi-Transparency

The unlatched semi-transparency attribute is controlled by bit [R3(3)<8>]. This bit has one of four possible assignments depending on how it is set up in [R7(3)<7:6>]. The four assignments are underline, semi-transparency, blinking, and CGROM bank select.

#### Notes:

1. The semi-transparency signal (SVBLANK), when active, is only valid with the background color. With the foreground color, SVBLANK is inactive. Therefore, characters do NOT take on a semi-transparent appearance (only the background does). This condition allows characters to be read without interference.
2. If both the transparency (background and foreground color are equal) and semi-transparency are activated, the transparency takes precedence over the semi-transparency. The VBLANK signal is High, and the SVBLANK signal is Low.

### Attribute\_8 Assignment

Depending on R7(3)<7:6>, bit 8 of the Attribute\_Data register, R3(3) (in character mode) can be assigned to control either “1st underline,” “semi-transparency,” “blinking,” or “CGROM bank select,” as indicated in Table 12.

**Table 12 Attribute Assignment**

R7(3)<7:6>	R3(3)<8>
00	1st underline (POR)
01	Semi-transparency
10	Blinking
11	CGROM bank1 select

## 2.13 Cursor

The cursor is a one-line pixel buffer. The cursor buffer is loaded via the DMA on every line where the cursor is displayed (no software support is required). Horizontal size is programmable at 16, 32, or 48 pixels wide, and vertical size is programmable from 1 to 63 lines per field. The color depth is 2 bits per pixel, 3 programmable colors and the transparency. Depending on R1(0)<d>, the cursor’s colors can be selected either from a current palette (R1(0)<d> = 0) or from Palette #6 (R1(0)<d> = 1). Refer to Table 15. The cursor image is stored in ROM as a bitmap. The number of cursors is limited by ROM size only.

The cursor is positioned by initializing cursor parameters in the beginning of every field.

Initialization occurs by setting the Cursor\_Info\_Load bit R7(3)<4> to 1, then writing sequentially to the R3(3) 16-bit parameters (COLOR, HPARAM, VPARAM and CADDR, respectively).

The cursor buffer is loaded from ROM at the leading edge of HSYNC wherever the horizontal line requires a cursor. This process halts the CPU for 3/5/7 cycles depending on the cursor's horizontal size. The cursor bitmap address pointer (CADDR) is incremented automatically.

Though the cursor can be displayed anywhere on the screen, limiting the cursor to the OSD area is best. Outside of the OSD area, the cursor can jitter or become distorted.

The cursor bitmap is organized as pixel data placed sequentially in the ROM. The data format is described below.

For the interlaced mode, even and odd cursor bitmaps must be defined separately. Proper selection occurs during the cursor initialization at the beginning of every field. See Figure 23, Table 13, and Table 14.

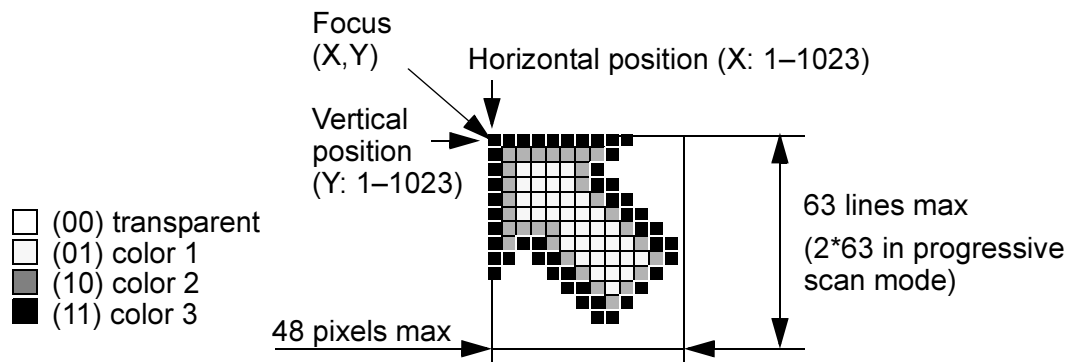

Figure 23 Cursor

### Example

```
LD    SR,%#60; select RegBank3
OR    EXT7,#%0010; enable Cursor_Info_Load
LD    EXT3,#(3*64 + 7*8 + 2); load CCOLOR: color3 = 3, color2 = 7, color1 = 2
LD    EXT3,#(2*1024 + 120); load HPARAM: hsize = 2 (32 pixels), hpos = 120
LD    EXT3,#(28*1024 + 55); load VPARAM: vsize = 28, vpos = 55
LD    EXT3,#%6000; load CADDR—cursor bitmap address
AND   EXT7,#%FFEF; disable Cursor_Info_Load, ready for OSD
```



**Table 13 Cursor Parameters**

Parameter	Reg field	Bit position	Data	Description
CADDR	CADDR	fedcba9876543210	%DDDD	Cursor bitmap address (pointer to cursor bitmap in ROM)
VPARAM	VSIZE	fedcba-----	1-63	Vertical size (lines in one field)
	VPOS	-----9876543210	1-1023	Vertical position (lines in one field)
HPARAM	n/a	fedc-----	n/a	Reserved
	HSIZE	----ba-----	00	No cursor
			01	16 pixels wide
			10	32 pixels wide
11			48 pixels wide	
HPOS	-----9876543210	1-1023	Horizontal position (pixels from trailing edge of HSYNC)	
CCOLOR	n/a	fedcba9-----	n/a	Reserved
	Color3	-----876-----	0-7	Cursor Color 2 assignment
	Color2	-----543---	0-7	Cursor Color 1 assignment
	Color1	-----210	0-7	Cursor Color 0 assignment

**Table 14 Memory Allocation for Cursor's Bitmap**

<b>16 Pixels Wide Mode</b>	
AddrN:	L0_P15_B0, L0_P14_B0, L0_P13_B0, ... , L0_P1_B0, L0_P0_B0
AddrN+1:	L0_P15_B1, L0_P14_B1, L0_P13_B1, ... , L0_P1_B1, L0_P0_B1
AddrN+2:	L1_P15_B0, L1_P14_B0, L1_P13_B0, ... , L1_P1_B0, L1_P0_B0
AddrN+3:	L1_P15_B1, L1_P14_B1, L1_P13_B1, ... , L1_P1_B1, L1_P0_B1
.....	
AddrN+2n:	Ln_P15_B0, Ln_P14_B0, Ln_P13_B0, ... , Ln_P1_B0, Ln_P0_B0
AddrN+2n+1:	Ln_P15_B1, Ln_P14_B1, Ln_P13_B1, ... , Ln_P1_B1, Ln_P0_B1
<b>32 Pixels Wide Mode</b>	
AddrN:	L0_P31_B0, L0_P30_B0, L0_P29_B0, ... , L0_P17_B0, L0_P16_B0
AddrN+1:	L0_P31_B1, L0_P30_B1, L0_P29_B1, ... , L0_P17_B1, L0_P16_B1
AddrN+2:	L0_P15_B0, L0_P14_B0, L0_P13_B0, ... , L0_P1_B0, L0_P0_B0



Table 14 Memory Allocation for Cursor's Bitmap (Continued)

AddrN+3:	L0_P15_B1, L0_P14_B1, L0_P13_B1, ... , L0_P1_B1, L0_P0_B1
AddrN+4:	L0_P31_B0, L0_P30_B0, L0_P29_B0, ... , L0_P17_B0, L0_P16_B0
AddrN+5:	L0_P31_B1, L0_P30_B1, L0_P29_B1, ... , L0_P17_B1, L0_P16_B1
.....	
AddrN+4n:	Ln_P31_B0, Ln_P30_B0, Ln_P29_B0, ... , Ln_P17_B0, Ln_P16_B0
AddrN+4n+1:	Ln_P31_B1, Ln_P30_B1, Ln_P29_B1, ... , Ln_P17_B1, Ln_P16_B1
AddrN+4n+2:	Ln_P15_B0, Ln_P14_B0, Ln_P13_B0, ... , Ln_P1_B0, Ln_P0_B0
AddrN+4n+3:	Ln_P15_B1, Ln_P14_B1, Ln_P13_B1, ... , Ln_P1_B1, Ln_P0_B1
<b>48 Pixels Wide Mode</b>	
AddrN:	L0_P47_B0, L0_P46_B0, L0_P45_B0, ... , L0_P13_B0, L0_P32_B0
AddrN+1:	L0_P47_B1, L0_P46_B1, L0_P45_B1, ... , L0_P33_B1, L0_P32_B1
AddrN+2:	L0_P31_B0, L0_P30_B0, L0_P29_B0, ... , L0_P17_B0, L0_P16_B0
AddrN+3:	L0_P31_B1, L0_P30_B1, L0_P29_B1, ... , L0_P17_B1, L0_P16_B1
AddrN+4:	L0_P15_B0, L0_P14_B0, L0_P13_B0, ... , L0_P1_B0, L0_P0_B0
AddrN+5:	L0_P15_B1, L0_P14_B1, L0_P13_B1, ... , L0_P1_B1, L0_P0_B1
AddrN+6:	L0_P47_B0, L0_P46_B0, L0_P45_B0, ... , L0_P33_B0, L0_P32_B0
AddrN+7:	L0_P47_B1, L0_P46_B1, L0_P45_B1, ... , L0_P33_B1, L0_P32_B1
.....	
AddrN+6n:	Ln_P47_B0, Ln_P46_B0, Ln_P45_B0, ... , Ln_P33_B0, Ln_P32_B0
AddrN+6n+1:	Ln_P47_B1, Ln_P46_B1, Ln_P45_B1, ... , Ln_P33_B1, Ln_P32_B1
AddrN+6n+2:	Ln_P31_B0, Ln_P30_B0, Ln_P29_B0, ... , Ln_P17_B0, Ln_P16_B0
AddrN+6n+3:	Ln_P31_B1, Ln_P30_B1, Ln_P29_B1, ... , Ln_P17_B1, Ln_P16_B1
AddrN+6n+4:	Ln_P15_B0, Ln_P14_B0, Ln_P13_B0, ... , Ln_P1_B0, Ln_P0_B0
AddrN+6n+5:	Ln_P15_B1, Ln_P14_B1, Ln_P13_B1, ... , Ln_P1_B1, Ln_P0_B1



where

- Lx\_Py\_Bz = line X, pixel Y, bit Z;
- Line 0 = first (top) cursor's line;
- Pixel 0 = first (left) cursor's pixel
- Bit 1, Bit 0 = most and least significant bit of the cursor's color defined as:
  - 00 = transparent
  - = 01 = Color 1
  - = 10 = Color 2
  - = 11 = Color 3

### 2.14 Color Palette Assignment

The Z90356 features a total of 16 color palettes, 8 of which are fixed and 8 of which are programmable. Palettes are selected by setting R7(3)<3:0>. Fixed palettes are defined in Table 15.

**Table 15 Fixed Palette Color Assignment  
(Color0 is Black; Color7 is White)**

Palette	Description	Color1			Color2			Color3			Color4			Color5			Color6		
		R	G	B	R	G	B	R	G	B	R	G	B	R	G	B	R	G	B
0	Digital RGB	00	00	11	00	11	00	00	11	11	11	00	00	11	00	11	11	11	00
1	Analog RGB	00	00	11	00	11	00	00	11	11	11	00	00	11	00	11	11	11	00
2	Greyscale_1	01	01	01	10	10	10	11	11	11	00	00	00	01	01	01	10	10	10
3	Greyscale_2	00	00	00	01	01	01	01	01	01	10	10	10	10	10	10	11	11	11
4	RGB_Cyan_2Grey	00	00	11	00	11	00	00	11	11	11	00	00	01	01	01	10	10	10
5	RGB_Magenta_2Grey	00	00	11	00	11	00	01	01	01	11	00	00	11	00	11	10	10	10
6	RGB_Yellow_2Grey	00	00	11	00	11	00	01	01	01	11	00	00	10	10	10	11	11	00
7	StarSight	00	11	11	10	11	10	10	10	10	11	01	01	11	11	10	11	11	00

Programmable palettes (8–15) are mapped to AR0–AR63 (8 registers per palette). The register and bit assignments for Palette # 11 are listed in Figure 24.

Programmable palettes are grouped into 2 banks (palettes 8–11 and 12–15). Palettes in the bank cannot be modified if another palette from the same bank is displayed. If on-the-fly palette modifications are required, an interleaving palette bank access must be created. One palette bank is used to display four colors, and the other bank is used for updates. See Figure 24.

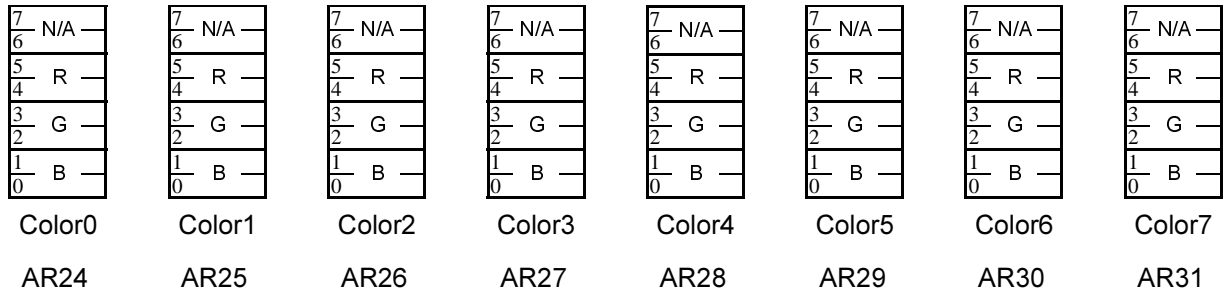

Figure 24 Programmable Palette Control at AR Register

## 2.15 Other Functions

### Video and Sound Attribute Control

Basic receiver functions such as color and volume can be controlled directly by six 6-bit pulse-width modulated ports.

### InfraRed Capture Function

The Infrared Remote Control data capture feature uses a capture register to hold the time value from one transition of IR data to the next.

Software periodically checks and reads the capture status and the value if a new capture occurs. Subsequent decoding and command passing of the received IR signal is under software control. Figure 25 illustrates the IR input circuit.

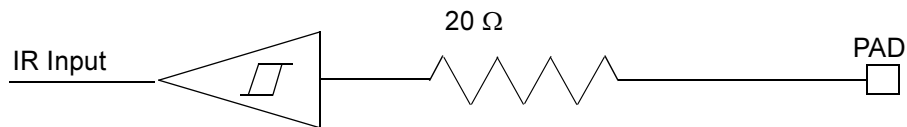

Figure 25 IR Capture Register Input

### Loop Filter

The Loop Filter pin configuration is represented in Figure 26.

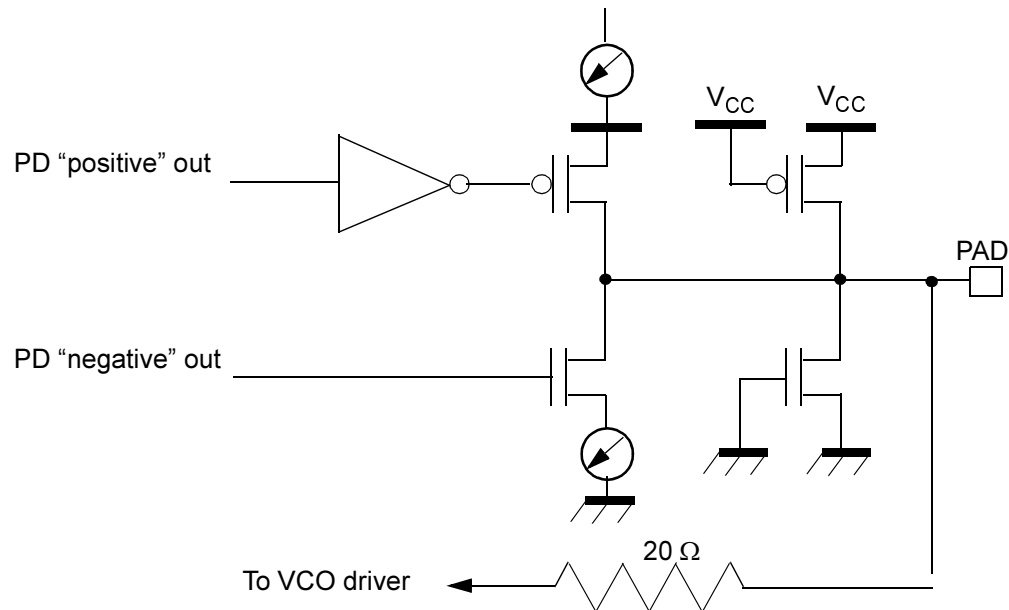

Figure 26 Loop Filter Pin Configuration

### Hardware Accelerated 4-Bit and 8-Bit Shifts

Hardware-accelerated byte and nibble shifts significantly reduce software overhead. Shifts are created by assigning one particular RAM location (%1FE) a special meaning. Depending on the R4(1)<e:d> settings data read from this address is either unmodified, rotated 4 bits left, 4 bits right, or byte swapped. See Table 16.

Table 16 R4(1)<e:d> Settings

R4(1)<e:d>	Function
00	Direct (unmodified)–POR
01	4-bit left rotate
10	4-bit right rotate
11	Byte swap

### Example

```
LD SR,#%20; Select RegBank1
LD A,EXT4; turn "hardware-supported shift" mode on
```



```

AND  A, #%9FFF;
OR   A, #%4000;
LD   EXT4, A; select "4-bit right rotate"
LD   A, #%3ED7; load A = %3ED7
LD   %1FE, A; write A to the RAM
LD   A, %1FE; A = %73ED
LD   A,EXT4; turn "hardware-supported rotate" mode on
OR   A,#%6000;
LD   EXT4, A; select "byte swap"
LD   A, %1FE; A = %D73E

```

### 3 Register Groups

Table 17 provides a summary of the registers in external banks.

**Table 17 Register Summary**

BANK	BANK Sub Address	READ Register	WRITE Register	Description
Bank0	7	dir1		9-bit I/O port 1 direction control
	6	dir0		16-bit I/O port 0 direction control
	5	port1		9-bit I/O port 1
	4	port0		16-bit I/O port 0
	3	I <sup>2</sup> C_int		I <sup>2</sup> C interface register
	2	pll_freq		PLL frequency control
	1	write control register		Cursor palette gauge Write control register
	0	Reserved		Reserved
Bank1	7	wdt_smr_ctl/Interrupt		SMR and WDT control and interrupt
	6	clock_ctl		Clock control (switch VCO/DOT)
	5	cap_1s_ctl		Counter timers control
	4	ADC_ctl		A/D converter control
	3	standard_ctl		Output H/VSYNC/blk control
	2	9-bit counter	STOP/WDT	Stop and WDT instructions, 9-bit counter
	1	sclk_freq		Stop/sleep/normal mode
	0	clamp_pos		Defines position of video clamp pulse



Table 17 Register Summary (Continued)

BANK	BANK Sub Address	READ Register	WRITE Register	Description
Bank2	7	CGROM offset register		CGROM offset register
	6	Shadow Control register		Defines right and left shadow color
	5	pwm_data6		8-bit PWM 6 data
	4	pwm_data5		8-bit PWM 5 data
	3	pwm_data4		8-bit PWM 4 data
	2	pwm_data3		8-bit PWM 3 data
	1	pwm_data2		8-bit PWM 2 data
	0	pwm_data1		8-bit PWM 1 data
Bank3	7	output palette		Output palette
	6	palette_color		Display palette color/underline color
	5	capture_data	I <sup>2</sup> C slave addr.	Capture register data
	4	osd_control		On screen display control
	3	attribute_data	vram_data	Character attribute/video RAM data
	2	ch_x1_lo_x3	cg_attribute	Character multiple/character graphics attribute
	1	lo_x2_mid_x3	cg_next_prv	Character multiple/next or previous data
	0	hi_x2_hi_x3	cg_current	Character multiple/current data

### 3.1 Register Description

The register file in the Z90356 is organized into four banks that can be selected by writing to bits 5 and 6 (Register Bank Selector bits) in the Status Register of the Z90356 core.

All registers are mapped into an external register space; each bank consists of 8 registers. The Status register is available to read or write at any time. The appropriate bank of registers must be selected before accessing the register. The software must keep track of which register bank is accessible at any time. Refer to Table 18 for register bank assignments.



**Table 18 Bank Assignments**

Bank	Status Register	Bank Functions
Bank0	xxxxx xxxxx x00x xxxxx	b I/O ports, I <sup>2</sup> C interface, PLL frequency, cursor
Bank1	xxxxx xxxxx x01x xxxxx	b Control registers
Bank2	xxxxx xxxxx x10x xxxxx	b PWM1–PWM5
Bank3	xxxxx xxxxx x11x xxxxx	b OSD, palette control

### 3.2 Bank0 (I/O Ports, I<sup>2</sup>C Interface, PLL Frequency, Cursor) Control Registers

Table 19 defines the bits for Register1–R1(0) Cursor Palette Control Register. Table 20 defines the bits for Register2–R2(0) PLL Frequency Data Register.

**Table 19 Register1, R1(0) Cursor Palette**

Bit	15	14	13	12	11	10	9	8
R/W	R/W	R/W	R/W	R/W	R/W	R/W	R/W	R/W
Reset	x	x	0	0	x	x	x	x
Bit	7	6	5	4	3	2	1	0
R/W	R/W	R/W	R/W	R/W	R/W	R/W	R/W	R/W
Reset	x	x	x	x	x	x	x	x

Note: R = Read W = Write X = Indeterminate

Reg Field	Bit Position	R	W	Data	Description
Reserved	f e-----	R	0	0	Reserved No effect
Cursor Palette	--d-----		W	1 0	Palette #6 (recommended) Current palette—POR
PgWritenEn	---c-----	R	W	1 0	Page Write Enable Page Write Disable—POR
PageWrite	----ba9876543210	R	W	xxxx	WritePage#



**Table 20 Register2, R2(0) PLL Frequency Data Register**

<b>Bit</b>	<b>15</b>	<b>14</b>	<b>13</b>	<b>12</b>	<b>11</b>	<b>10</b>	<b>9</b>	<b>8</b>
R/W	R/W	R/W	R/W	R/W	R/W	R/W	R/W	R/W
Reset	0	0	1	0	0	0	0	0
<b>Bit</b>	<b>7</b>	<b>6</b>	<b>5</b>	<b>4</b>	<b>3</b>	<b>2</b>	<b>1</b>	<b>0</b>
R/W	R/W	R/W	R/W	R/W	R/W	R/W	R/W	R/W
Reset	0	1	1	1	0	0	0	0

Note: R = Read W = Write X = Indeterminate

Reg Field	Bit Position	R	W	Data	Description
M_disable	f-----	R	W	1 0	I <sup>2</sup> C Master interface disabled I <sup>2</sup> C Master interface enabled–POR
S_disable	-e-----	R	W	1 0	I <sup>2</sup> C Slave interface disabled I <sup>2</sup> C Slave interface enabled–POR
I <sup>2</sup> CM_mux	--d-----	R	W	1 0	Select I <sup>2</sup> MSD2, I <sup>2</sup> MSC2–POR Select I <sup>2</sup> MSD1, I <sup>2</sup> MSC1
I <sup>2</sup> C_Out_Resistance	---c-----	R	W	1 0	600Ω output resistance Normal CMOS port output resistance–POR
I <sup>2</sup> C_speed_range	----b-----	R	W	1 0	Low speed range (10 kHz, 50 kHz) High speed range (100 kHz, 400 kHz)–POR
Reserved	-----a-----	R	W		Return “0” No effect
P46/ HSYNC2	-----9-----	R	W	1 0	HSYNC logic takes input from Pin 46 HSYNC logic takes input from HSYNC pin–POR
P07/ ComSYNC	-----8-----	R	W	1 0	Composite Sync Output P07 I/O–POR
PLL_data	-----76543210	R	W	xx	PLL divider = 256 + xx

If the master or slave I<sup>2</sup>C interface is enabled, the corresponding I/Os (Port01 and Port02 for the slave, Port11 and Port12 for the master) must be assigned as outputs.

The VCO, DOT, and SCLK frequency are defined as the following:

$$F_{VCO} = F_{DOT} = F_{SCLK} = XTAL * (256 + PLL_{DATA})$$

Therefore, XTAL = 32.768 KHz.



At POR, the PLL frequency data register is preset to %70, which corresponds to the VCO frequency of 12.058 MHz.

The PLL\_data field can be loaded with any value from %00. This value corresponds to an  $SCLK = 256 * XTAL$  up to %FF, which corresponds to an  $SCLK = 511 * XTAL$ .

Table 21 through Table 25 describe the bits in registers 3 through 7.



**Table 21 Register3, R3(0) I<sup>2</sup>C Interface Register**

<b>Bit</b>	<b>15</b>	<b>14</b>	<b>13</b>	<b>12</b>	<b>11</b>	<b>10</b>	<b>9</b>	<b>8</b>
R/W	R/W	R/W	R/W	R/W	R/W	R/W	R/W	R/W
Reset	0	0	0	0	0	1	x	x
<b>Bit</b>	<b>7</b>	<b>6</b>	<b>5</b>	<b>4</b>	<b>3</b>	<b>2</b>	<b>1</b>	<b>0</b>
R/W	R/W	R/W	R/W	R/W	R/W	R/W	R/W	R/W
Reset	x	x	x	x	x	x	x	x

Note: R = Read W = Write X = Indeterminate

Reg Field	Bit Position	R	W	Data	Description
Command	fed-----	R			Return 0 See Table 9 and Table 10 for a full description.
			W	%D	
Toggle	---c-----	R			Slave interface 0 Master interface—POR condition
			W	1	Toggle active I <sup>2</sup> C interface
				0	No effect
Reset	----b-----	R			Return 0 Reset Slave I <sup>2</sup> C interface if bit <c> = 1 Reset Master I <sup>2</sup> C interface if bit <c> = 0
			W	1	Reset Slave I <sup>2</sup> C interface if bit <c> = 1
				0	Reset Master I <sup>2</sup> C interface if bit <c> = 0
					No effect
Slave_mode	-----a-----	R			Slave mode is active (POR condition) 0 Slave mode is inactive
			W		No effect
SlaveBusy	-----9-----	R			Slave I <sup>2</sup> C interface is busy 0 Slave I <sup>2</sup> C interface is idle
			W		No effect
MasterBusy	-----8-----	R			Master I <sup>2</sup> C interface is busy 0 Master I <sup>2</sup> C interface is idle
			W		No effect
Data	-----76543210	R		xx	Received data
			W	xx	Data to be sent

Data written to R3(0)<cb> requires 4 cycles before being applied. Consecutive writings to these bits require at least a 6-cycle delay.

The received data is available for reading only when the “busy” bit is reset to a “0.” When POR, the speed of the I<sup>2</sup>C interface is set to “Low.”



**Table 22 Register4, R4(0) Port 0 Data Register**

<b>Bit</b>	<b>15</b>	<b>14</b>	<b>13</b>	<b>12</b>	<b>11</b>	<b>10</b>	<b>9</b>	<b>8</b>
R/W	R/W	R/W	R/W	R/W	R/W	R/W	R/W	R/W
Reset	x	x	x	x	x	x	x	x
<b>Bit</b>	<b>7</b>	<b>6</b>	<b>5</b>	<b>4</b>	<b>3</b>	<b>2</b>	<b>1</b>	<b>0</b>
R/W	R/W	R/W	R/W	R/W	R/W	R/W	R/W	R/W
Reset	x	x	x	x	x	x	x	x

Note: R = Read W = Write X = Indeterminate

<b>Reg Field</b>	<b>Bit Position</b>	<b>R</b>	<b>W</b>	<b>Data</b>	<b>Description</b>
Port_data	fedcba9876543210	R		xxxx	If a port is configured in Input mode, enter the input data onto the port pins.
			W	xxxx	If a port is configured in Output mode, then the data is written directly to the port data.



**Table 23 Register5, R5(0) Port 1 Data Register**

<b>Bit</b>	<b>15</b>	<b>14</b>	<b>13</b>	<b>12</b>	<b>11</b>	<b>10</b>	<b>9</b>	<b>8</b>
R/W	R/W	R/W	R/W	R/W	R/W	R/W	R/W	R/W
Reset	x	x	x	x	x	x	x	x
<b>Bit</b>	<b>7</b>	<b>6</b>	<b>5</b>	<b>4</b>	<b>3</b>	<b>2</b>	<b>1</b>	<b>0</b>
R/W	R/W	R/W	R/W	R/W	R/W	R/W	R/W	R/W
Reset	x	x	x	x	x	x	x	x

Note: R = Read W = Write X = Indeterminate

Reg Field	Bit Position	R	W	Data	Description
Reserved	fedcba9-----	R			Return 0 No Effect
Port_data	-----876543210	R		xxxx	If a port is configured in Input mode, enter the input data onto the port pins.
			W	xxxx	If a port is configured in Output mode, then the data is written directly to the port data.

**Table 24 Register6, R6(0) Port 0 Direction Register**

<b>Bit</b>	<b>15</b>	<b>14</b>	<b>13</b>	<b>12</b>	<b>11</b>	<b>10</b>	<b>9</b>	<b>8</b>
R/W	R/W	R/W	R/W	R/W	R/W	R/W	R/W	R/W
Reset	1	1	1	1	1	1	1	1
<b>Bit</b>	<b>7</b>	<b>6</b>	<b>5</b>	<b>4</b>	<b>3</b>	<b>2</b>	<b>1</b>	<b>0</b>
R/W	R/W	R/W	R/W	R/W	R/W	R/W	R/W	R/W
Reset	1	1	1	1	1	1	1	1

Note: R = Read W = Write X = Indeterminate

Reg Field	Bit Position	R	W	Data	Description
Port_direction	fedcba9876543210	R	W	xxxx	1: Input mode for corresponding bit 0: Output mode for corresponding bit



**Table 25 Register7, R7(0) Port 1 Direction Register**

<b>Bit</b>	<b>15</b>	<b>14</b>	<b>13</b>	<b>12</b>	<b>11</b>	<b>10</b>	<b>9</b>	<b>8</b>
R/W	R/W	R/W	R/W	R/W	R/W	R/W	R/W	R/W
Reset	x	x	x	x	x	x	x	1
<b>Bit</b>	<b>7</b>	<b>6</b>	<b>5</b>	<b>4</b>	<b>3</b>	<b>2</b>	<b>1</b>	<b>0</b>
R/W	R/W	R/W	R/W	R/W	R/W	R/W	R/W	R/W
Reset	1	1	1	1	1	1	1	1

Note: R = Read W = Write X = Indeterminate

Reg Field	Bit Position	R	W	Data	Description
Reserved	fedcba9-----	R			Return 0 No Effect
Port_direction	-----876543210	R		xxxx	1: Input mode for corresponding bit 0: Output mode for corresponding bit
			W		

### 3.3 Bank1 (Control Registers)

Table 26 through Table 33 provide bit functions for Bank 1 Control registers.



**Table 26 Register0, R0(1) Clamp Position Register**

<b>Bit</b>	<b>15</b>	<b>14</b>	<b>13</b>	<b>12</b>	<b>11</b>	<b>10</b>	<b>9</b>	<b>8</b>
R/W	R/W	R/W	R/W	R/W	R/W	R/W	R/W	R/W
Reset	1	1	1	1	0	0	0	0
<b>Bit</b>	<b>7</b>	<b>6</b>	<b>5</b>	<b>4</b>	<b>3</b>	<b>2</b>	<b>1</b>	<b>0</b>
R/W	R/W	R/W	R/W	R/W	R/W	R/W	R/W	R/W
Reset	0	x	x	x	x	x	x	x

Note: R = Read W = Write X = Indeterminate

Reg Field	Bit Position	R	W	Data	Description
Disable_clamp_1	f-----	R	W	1 0	ADC0 Clamp generation is disabled ADC0 Clamp generation is enabled
Disable_clamp_2	-e-----	R	W	1 0	ADC5 Clamp generation is disabled ADC5 Clamp generation is enabled
Disable_tip_clamp	--d-----	R	W	1 0	ADC0 Tip clamp is disabled–POR ADC0 Tip clamp is enabled
Counter_input	---c-----	R	W	1 0	Counter takes input from P06–POR Counter takes input from internal HSYNC Separator
ARenable	----b-----	R	W	1 0	AR enabled AR disabled–POR
Reserved	-----a987-----	R	W		Return “0” No effect
Position	-----6543210	R	W	xx	Position of clamp pulse (from leading edge of the H-FLYBACK)

At POR the disable\_clamp bit is set to 1.



The clamp pulse is generated if Enabled (bit <f>) and the SCLK frequency are switched back to PVCO. The SVCO/PVCO flag in R6(1) must be reset to 0 before the current HSYNC, regardless of whether the SVCO is enabled or disabled.

The clamp position is defined by the Position field. The width of the clamp pulse cannot be modified and is set to 1us. The value that can be assigned to the “Position” field must be >% 10 and <% 7F. The time interval between the leading edge of the H-FLYBACK and the beginning of the clamp pulse can be calculated from the following equation:

$$T_{DELAY} = \text{Position} \left( \frac{1}{T_{SCLK}} \right) = \text{Position} \times 82\text{ns}$$

**Table 27 Register1, R1(1) Speed Control Register**

<b>Bit</b>	<b>15</b>	<b>14</b>	<b>13</b>	<b>12</b>	<b>11</b>	<b>10</b>	<b>9</b>	<b>8</b>
R/W	R/W	R/W	R/W	R/W	R/W	R/W	R/W	R/W
Reset	0	0	0	0	0	0	0	0
<b>Bit</b>	<b>7</b>	<b>6</b>	<b>5</b>	<b>4</b>	<b>3</b>	<b>2</b>	<b>1</b>	<b>0</b>
R/W	R/W	R/W	R/W	R/W	R/W	R/W	R/W	R/W
Reset	0	0	0	0	0	0	0	0

Note: R = Read W = Write X = Indeterminate

Reg Field	Bit Position	R	W	Data	Description
Reserved	fedcba98765432--				Reserved (Return 0)
Fast_enable	-----1-	R	W	1 0	PVCO/SVCO enabled PVCO/SVCO disabled–POR
Fast_slow	-----0	R	W	1 0	SCLK is 12.058 MHz SCLK is 32.768 KHz–POR

When a POR, SMR, or WDT reset occurs, both the Fast\_enable and Fast/Slow are reset to 0. This event corresponds to an SCLK frequency of 32.768 kHz.

To switch from a 32.768-kHz SCLK to 12 MHz, use the following procedure:

1. Set the H\_Position field R6(1)<3:0> to a nonzero value.
2. Enable the primary and secondary VCOs (set the Fast\_enable bit R1(1)<1> to “1”).



3. Wait for one second (1s) for the 12-MHz PLL to stabilize (about 50000 clock cycles). The delay depends on the external PLL filter and CAN vary significantly.
4. Switch the SCLK to a fast clock (set Fast/Slow bit R1(1)<0> to 1).
5. Simultaneously set the H\_Position field R6(1)<3:0> to 0FH and the No\_Switch field R6(1)<4> to 1 (no clock switch).

To switch from the 12-MHz SCLK to 32.768 kHz, use the following procedure:

1. Switch the SCLK to a 32.768-kHz clock (set Fast/Slow bit R1(1)<0> to 0).
2. Wait for more than R2(0)<7:0> + 256 clock cycles (approximately 32 μS) for the SCLK to be switched.
3. Set the HSYNC\_DELAY field R6(1)<3:0> to 0FH.
4. Disable the primary and secondary VCOs (set the Fast\_enable bit R1(1)<1> to 0).

**Table 28 Register2, R2(1) WDT/STOP (write only) and 9-Bit Counter (read only) Control Register**

<b>Bit</b>	<b>15</b>	<b>14</b>	<b>13</b>	<b>12</b>	<b>11</b>	<b>10</b>	<b>9</b>	<b>8</b>
R/W	R/W	R/W	R/W	R/W	R/W	R/W	R/W	R/W
Reset	x	x	x	x	x	x	x	x
<b>Bit</b>	<b>7</b>	<b>6</b>	<b>5</b>	<b>4</b>	<b>3</b>	<b>2</b>	<b>1</b>	<b>0</b>
R/W	R/W	R/W	R/W	R/W	R/W	R/W	R/W	R/W
Reset	x	0	0	0	0	0	0	0

Note: R = Read W = Write X = Indeterminate

Reg Field	Bit Position	R	W	Data	Description
Counter_value	fedcba987-----	R	W		Counter on Port06 value No effect
Reserved	-----65432--	R	W		Return 0 No effect
WDT_instr	-----1-	R	W	1 0	Return 0 WDT enable, WDT reset No effect
STOP_instr	-----0	R	W	1 0	Return 0 Stop No effect



When a POR, SMR or a WDT reset occurs, the WDT is disabled. The WDT can be reenabled only after the PVCO and SVCO are enabled, and the part is switched into a Fast mode (SCLK = 12 MHz).

When switching the part into a SLOW mode (SCLK = 32.768 kHz), the WDT halts. To return to Fast mode, the WDT must be initialized again.

**Table 29 Register3, R3(1) Standard Control Register**

<b>Bit</b>	<b>15</b>	<b>14</b>	<b>13</b>	<b>12</b>	<b>11</b>	<b>10</b>	<b>9</b>	<b>8</b>
R/W	R/W	R/W	R/W	R/W	R/W	R/W	R/W	R/W
Reset	0	0	0	0	0	0	0	0
<b>Bit</b>	<b>7</b>	<b>6</b>	<b>5</b>	<b>4</b>	<b>3</b>	<b>2</b>	<b>1</b>	<b>0</b>
R/W	R/W	R/W	R/W	R/W	R/W	R/W	R/W	R/W
Reset	0	0	0	x	x	x	0	0

Note: R = Read W = Write X = Indeterminate

Reg Field	Bit Position	R	W	Data	Description
Counter_reset	f-----	R		1 0	Return 0 Reset Counter on Port06
			W		No effect
Counter_ON/OFF	-e-----	R	W	1 0	Counter on Port06 is ON Counter is OFF–POR condition
Mask_HVSYNC	--d-----	R	W	1 0	Disable HVSYNC output HVSYNC IN/OUT–POR condition
Char_size_16_18/20	---c-----	R	W	1 0	16x20 character matrix 16x16 or 16x18 character matrix– POR
Bank0_sel	----ba-----	R	W	00 01 10 11	RAM Bank 00–POR RAM Bank 01 RAM Bank 02 Reserved
RGBC/Port1	-----9-----	R	W	1 0	SCLK, R<1:0>, G<1:0>, B<1:0> P16,P08,P10,P13,P18,P15,P14
I <sup>2</sup> C_HI/LO_speed	-----8-----	R	W	1 0	HI speed (400/50 kHz) LO speed (100/10 kHz)–POR



Reg Field	Bit Position	R	W	Data	Description
CGROM bank	-----7-----	R	W	1 0	Bank1 is selected (starts @%1000) Bank0 is selected (starts @%0000)
SVBLANK/P0f	-----6-----	R	W	1 0	Semi-transparency P0f output
OSD_on/off	-----5-----	R	W	1 0	OSD is enabled OSD is disabled-POR
RGB_polarity	-----4-----	R	W	1 0	Negative Positive
Positive/Negative	-----3-----	R	W	1 0	Negative HVS SYNC in output mode Positive HVS SYNC in output mode
SYNC/BLANK	-----2-----	R	W	1 0	HVBLANK outputs HVS SYNC outputs
25/30_Hz and HV_polarity	-----10-----	R	W		Internal mode <i>only</i> (TV Standard)
				10 00 11 01	50 Hz/625 lines support 60 Hz/525 lines support-POR External mode <i>only</i> (HV Polarity) Positive Negative

Two bits define the polarity of the HVS SYNC signals. Bit <3> defines polarity of the signals when they are configured as outputs (it does not affect the internal HV-SYNC signals). Bit <1> defines the polarity of the external HV-SYNC signals, affecting the synchronization of the device.

**Notes:**

1. The composite SYNC is active in internal mode only.
2. When using the internally-generated COMPOSITE SYNC signal, be sure the SCLK is set to 12.09 MHz (R2(0)<7:0> = %71). This action helps ensure the best HSYNC frequency approximation.

**Table 30 Register4, R4(1) ADC Control Register**

Bit	15	14	13	12	11	10	9	8
R/W	R/W	R/W	R/W	R/W	R/W	R/W	R/W	R/W
Reset	0	0	0	0	0	0	0	0
Bit	7	6	5	4	3	2	1	0



**Table 30 Register4, R4(1) ADC Control Register (Continued)**

R/W	R/W	R/W	R/W	R/W	R/W	R/W	R/W	R/W
Reset	0	0	0	0	x	x	x	x

Note: R = Read W = Write X = Indeterminate

Reg Field	Bit Position	R	W	Data	Description
Reserved	f-----	R	W	0	Reserved No Effect
HW_shift	-ed-----	R	W	00 01 10 11	Direct (unmodified)–POR 4-bit shift left 4-bit shift right Byte swap
HSYNC_edge*	---c-----	R	W	1 0	HSYNC is leading edge active HSYNC is trailing edge active–POR
ADC_ref	----b-----	R	W	1 0	ADCs use AV <sub>CC</sub> and AGND as reference voltage ADCs use 2.0V and 1.5V as reference voltage–POR
ADC_select	-----a-----	R	W	1 0	ADC4, ADC5 select ADC0, ADC1, ADC2, ADC3 select– POR condition
ADCdata- Packing	-----9-----	R	W		ADC data packing is on ADC data packing is off–POR
Reserved	-----8-----	R	W		Return “0” No effect
ADCspeed	-----76-----	R	W	00 01 10 11	Single conversion–POR condition SCLK/4 SCLK/6 SCLK/8
ADCsource	-----54-----	R	W	00 01 10 11	ADC0 (CVI)/ADC4 (P04)–POR ADC1 (P17)/ADC5 ADC2 (P00) ADC3 (P05)
ADCdata	-----3210	R	W	%D	ADC data No effect

**Note:** \*If HSYNC is Leading Edge Active (R4(1)<c> = 1),the actual interrupt is delayed from the leading edge of HSYNC by 72 cycles (~6uS @ 12MHz).



ADC0 has a signal range from 1.5 to 2.0 V. This field is always connected to the Composite Video Input pin and can be clamped to a Ref- voltage (1.5V).

ADC1, ADC2, ADC3, and ADC4 have a signal range from 0 to 5.0 V.

ADC5 features a signal range from 1.5 to 2.0 V. For this field, the input signal can be clamped to a Ref+ voltage (2.0V).

To use the I/O pin as an ADC input, the corresponding port must be set up as an input (refer to R4(0) and R6(0)).

**Table 31 Register5, R5(1)Timer Control Register**

<b>Bit</b>	<b>15</b>	<b>14</b>	<b>13</b>	<b>12</b>	<b>11</b>	<b>10</b>	<b>9</b>	<b>8</b>
R/W	R/W	R/W	R/W	R/W	R/W	R/W	R/W	R/W
Reset	x	x	x	x	0	0	x	x
<b>Bit</b>	<b>7</b>	<b>6</b>	<b>5</b>	<b>4</b>	<b>3</b>	<b>2</b>	<b>1</b>	<b>0</b>
R/W	R/W	R/W	R/W	R/W	R/W	R/W	R/W	R/W
Reset	x	x	x	x	x	x	x	x

Note: R = Read W = Write X = Indeterminate

Reg Field	Bit Position	R	W	Data	Description
CAPint_r	f-----	R		1	Rising edge is captured
				0	No rising edge is captured
			W	1	Reset flag
				0	No effect
CAPint_f	-e-----	R		1	Falling edge is captured
				0	No falling edge is captured
			W	1	Reset flag
				0	No effect
Tout_1s	--d-----	R		1	Timeout of 1s timer
				0	No timeout of 1s timer
			W	1	Reset flag
				0	No effect
Tout_CAP	---c-----	R		1	Timeout of Capture timer
				0	No timeout of Capture timer
			W	1	Reset flag
				0	No effect
Reserved	----ba-----	R			Return "0"
			W		No effect



Reg Field	Bit Position	R	W	Data	Description
Speed_1s	-----98-----	R	W	00	1s
				01	250 ms
				10	62.5 ms
				11	15.625 ms
Port09/ CAP_int*	-----7-----	R	W	1	int2 source is Port09
				0	int2 source is Capture timer
CAP_halt*	-----6-----	R	W	1	Capture timer is halted
				0	Capture timer is running
CAP_edge*	-----54-----	R	W	00	No Capture
				01	Capture on rising edge only
				10	Capture on falling edge only
				11	Capture on both edges
CAP_glitch*	-----32--	R	W	00	Glitch filter is disabled
				01	<8TSCLK is filtered out
				10	<32TSCLK is filtered out
				11	<128TSCLK is filtered out
CAP_speed *	-----10	R	W	00	SCLK/4
				01	SCLK/8
				10	SCLK/16
				11	SCLK/32

\*Resetting a Capture Timer flag does not modify Capture Counter and/or Capture register data. When the glitch filter is enabled, the duration of the pulse is decreased by CAP\_glitch value.

**Table 32 Register6, R6(1) Clock Switch Control Register**

<b>Bit</b>	<b>15</b>	<b>14</b>	<b>13</b>	<b>12</b>	<b>11</b>	<b>10</b>	<b>9</b>	<b>8</b>
R/W	R/W	R/W	R/W	R/W	R/W	R/W	R/W	R/W
Reset	0	0	0	0	0	0	0	0
<b>Bit</b>	<b>7</b>	<b>6</b>	<b>5</b>	<b>4</b>	<b>3</b>	<b>2</b>	<b>1</b>	<b>0</b>
R/W	R/W	R/W	R/W	R/W	R/W	R/W	R/W	R/W
Reset	0	0	0	1	x	x	x	x

Note: R = Read W = Write X = Indeterminate

Reg Field	Bit Position	R	W	Data	Description
Reserved	fedcba9876-----	R	W		Return 0 No effect



Reg Field	Bit Position	R	W	Data	Description
SVCO/PVCO	-----5-----	R		1	SCLK = SVCO (flag)
				0	SCLK = PVCO (flag) POR
			W	1	Switch SCLK to PVCO
				0	No effect
No_Switch	-----4-----	R	W	1	SCLK = PVCO, no clock switching—POR
				0	Clock switching is enabled
H_Position	-----3210	R	W	%D	Defines delay of H <sub>SYNC</sub> interrupt by 4X SCLK cycles

### H\_Position

The H\_position field defines the delay between when the Z90356 receives an H-sync and when the H-sync interrupt is executed. Because the On-Screen Display is controlled by software this delay allows fine tuning for On-Screen Display centering. At Power On Reset (POR) this value is in an unknown state. If this value is set to 0x0, neither the H<sub>SYNC</sub> interrupt nor clock switching can execute. To receive an H<sub>SYNC</sub> interrupt, valid delay values are between 0x1 and 0xF. Valid delay values produce a delay according to the following equation:

$$11 + 4 * (H\_position - 1)$$

For example, an H\_position setting of 0xF produces a delay of 67 system clock cycles after the trailing edge of H<sub>SYNC</sub>.

$$11 + 4 * (15 - 1) = 67$$

### No\_Switch

The No\_switch bit determines if the system clock is permanently set to the Primary VCO (PVCO) or allowed to switch between PVCO and the Secondary VCO (SVCO). This bit is set to 1 (NO clock switching) at power up reset.

**Caution:** After the system has been switched to fast (12 MHz) clock both signals feeding into this switch MUST be PVCO BEFORE the switch setting is changed. Otherwise a short system clock can result which causes the processor to run at a higher frequency than specified. The instruction fetched from memory, at the location with the out-of-spec frequency, can be corrupted!

To ensure safe clocks, the following practices are recommended:

1. Set the No\_switch to the required setting before switching from the 32.768 kHz to the fast (12 MHz) clock and leave it there permanently.



2. Use the following procedure when changing from Switching VCO to permanent PVCO while running from the fast clock:
  - Simultaneously set the H\_position delay to 0x0, while leaving the No\_switch enabled (0), and the SVCO/PVCO left as (0).
  - Wait a minimum of 80 clock cycles to flush any H-sync out of the system.
  - Simultaneously Switch SVCO/PVCO to PVCO (write 1 into R6(1)<5>), while leaving the No\_switch enabled (0), and the H\_position delay at 0x0.
  - Wait for 3 system clock cycles to be sure that the clock has had time to switch to PVCO.
  - Switch No\_switch to No clock switch (write 1 into R6(1)<6>). The H\_position can be set to none-zero at this time as well.
  
3. Use the following procedure when changing from permanent PVCO to Switching VCO while running from the fast clock.
  - Simultaneously set the H\_position delay to 0x0, while leaving the No\_switch disabled (1), and the SVCO/PVCO setting as don't care (0).
  - Wait a minimum of 80 clock cycles to flush residual H-sync out of the system.
  - Simultaneously switch SVCO/PVCO to PVCO (write 1 into R6(1)<5>), while leaving the No\_switch disabled (1), and the H\_position delay at 0x0.
  - Wait 3 system clock cycles to be sure that the clock has had time to switch to PVCO.
  - Switch No\_switch to Clock switching is Enabled (write 0 into R6(1)<6>). The H\_position can be set to none-zero at this time as well.

### **SVCO/PVCO**

The SVCO/PVCO bit when read back determines the current setting of the system clock. Writing a 1 to this bit switches the system clock from its current setting to PVCO. This switch has a glitch filter that removes random voltage spikes. It must be changed back to PVCO. The Z90356 switches to the SVCO automatically when it receives an H-sync interrupt. This mechanism exists to synchronize the system clock exactly with the H-sync trailing edge. The result is a sharp start of the OSD, jitter free.

An example of a typical SVCO/PVCO switching follows:

1. System clock is set to PVCO.
2. H-sync interrupt occurs. (The system clock has automatically been set to the SVCO). OSD code is executed inside of the H-sync Interrupt Service Routine (ISR).
3. Before leaving the ISR, the user switches the clock back to PVCO.



The clamp pulse (defined in R0(1)) is generated only if the SVCO/PVCO switch is set to PVCO before receiving an H<sub>SYNC</sub>. The software provides the correct switch setting before every H<sub>SYNC</sub>.

Table 33 lists the interrupt/WDT for the WST/SMR control register.

**Table 33 Register7, R7(1) Interrupts/WDT/SMR Control Register**

<b>Bit</b>	<b>15</b>	<b>14</b>	<b>13</b>	<b>12</b>	<b>11</b>	<b>10</b>	<b>9</b>	<b>8</b>
R/W	R/W	R/W	R/W	R/W	R/W	R/W	R/W	R/W
Reset	x	x	x	x	x	x	x	x
<b>Bit</b>	<b>7</b>	<b>6</b>	<b>5</b>	<b>4</b>	<b>3</b>	<b>2</b>	<b>1</b>	<b>0</b>
R/W	R/W	R/W	R/W	R/W	R/W	R/W	R/W	R/W
Reset	0	x	x	x	x	x	x	x

Note: R = Read W = Write X = Indeterminate

Reg Field	Bit Position	R	W	Data	Description
Int_priority	fed-----	R	W	x	See Table 34.
Int_mask	---cba-----	R	W	1xx 0xx x1x x0x xx1 xx0	int2 is enabled int2 is disabled int1 is enabled int1 is disabled int0 is enabled int0 is disabled
WDTspeed	-----98-----	R	W	00 01 10 11	1.83 ms 7.68 ms 31.12 ms 124.8 ms
SMRflag	-----7-----	R	W	0 1	No Stop-Mode Recovery-POR Stop-Mode Recovery No effect
SMR polarity	-----6-----	R	W	0 1	OR of all SMR sources NAND of all SMR sources



Reg Field	Bit Position	R	W	Data	Description
SMRsource	-----543210	R	W	xx	Bit which corresponds to a "1" in xx binary representation is active
smr5	-----5-----				p09
smr4	-----4-----				p14
smr3	-----3-----				p13
smr2	-----2-----				p12
smr1	-----1-----				p11
smr0	-----0-----				p10

The final result of the Stop-Mode Recovery (SMR) is RESET. Ports selected for SMR must be assigned as inputs, while the other SMR ports must be assigned as outputs exhibiting an inactive value. If any SMR source is active, and the Stop Mode is executed, the part resets immediately.

All core interrupts are set to  $int0 > int1 > int2$ . These priorities *cannot* be changed and are embedded into the core. However, Z90356 architecture provides flexibility to change the priority of the interrupts by switching the interrupt sources between interrupt inputs of the Z90356 core. The correspondence between  $H_{SYNC}$ ,  $V_{SYNC}$  and  $1s/CAP$  interrupts sources, and  $int0$ ,  $int1$ , and  $int2$  interrupts inputs of the Z90356 are listed in Table 34.

**Table 34 Interrupt Priority**

Int_Priority Field	HSYNC Is Switched To:	VSYNC Is Switched To:	1s/CAP Is Switched To:	Int_Priority Field
0 0 0	int0	int1	int2	0 0 0
0 0 1	int0	int2	int1	0 0 1
0 1 0	int1	int0	int2	0 1 0
0 1 1	int2	int0	int1	0 1 1
1 0 0	int1	int2	int0	1 0 0
1 0 1	int2	int1	int0	1 0 1

### 3.4 Bank2 (PWM Registers)

Table 35 lists the bits for the PWM registers.



**Table 35 Register0–Register5, R0(2)–R5(2) PWM 1–6 Registers**

<b>Bit</b>	<b>15</b>	<b>14</b>	<b>13</b>	<b>12</b>	<b>11</b>	<b>10</b>	<b>9</b>	<b>8</b>
R/W	R/W	R/W	R/W	R/W	R/W	R/W	R/W	R/W
Reset	0	0	0	0	0	0	0	0
<b>Bit</b>	<b>7</b>	<b>6</b>	<b>5</b>	<b>4</b>	<b>3</b>	<b>2</b>	<b>1</b>	<b>0</b>
R/W	R/W	R/W	R/W	R/W	R/W	R/W	R/W	R/W
Reset	x	x	x	x	x	x	x	x

Note: R = Read W = Write X = Indeterminate

Reg Field	Bit Position	R	W	Data	Description
Reserved	fedcba98-----	R			Return 0 No effect
PWM_data	-----76543210	R	W	xx	8-bit PWM data

All of the PWMs feature push-pull. Outputs from all PWMs are staged by one PVCO clock. The repetition frequency of the PWM output signals can be calculated from the following equation:

$$F_{PWM} = \frac{F_{PVCO}}{8 - 256} = \frac{12MHz}{2048} = 6kHz$$

When reset, PWM\_data registers are not initialized; however, PWM output is set to 0. Because the PWM is clocked with PVCO, it is better to initialize the PWM\_data before enabling PVCO.

Table 36 lists the bits for the shadow control register.

Table 37 lists the bits for the CGROM offset register.



**Table 36 Register6, R6(2) Shadow Control Register**

<b>Bit</b>	<b>15</b>	<b>14</b>	<b>13</b>	<b>12</b>	<b>11</b>	<b>10</b>	<b>9</b>	<b>8</b>
R/W	R/W	R/W	R/W	R/W	R/W	R/W	R/W	R/W
Reset	0	0	0	0	0	0	0	0
<b>Bit</b>	<b>7</b>	<b>6</b>	<b>5</b>	<b>4</b>	<b>3</b>	<b>2</b>	<b>1</b>	<b>0</b>
R/W	R/W	R/W	R/W	R/W	R/W	R/W	R/W	R/W
Reset	x	x	x	x	x	x	x	x

Note: R = Read W = Write X = Indeterminate

Reg Field	Bit Position	R	W	Data	Description
Reserved	fe-----	R	W		Return 0 No effect
Lshadow-Color	--dcb-----	R	W	xx	Left shadow color-POR = 0
Rshadow-Color	-----a98-----	R	W	xx	Right shadow color-POR = 0
Reserved	-----76543210	R	W		Return 0 No effect

**Table 37 Register7, R7(2) CGROM Offset Register**

<b>Bit</b>	<b>15</b>	<b>14</b>	<b>13</b>	<b>12</b>	<b>11</b>	<b>10</b>	<b>9</b>	<b>8</b>
R/W	R/W	R/W	R/W	R/W	R/W	R/W	R/W	R/W
Reset	0	0	0	0	0	0	0	0
<b>Bit</b>	<b>7</b>	<b>6</b>	<b>5</b>	<b>4</b>	<b>3</b>	<b>2</b>	<b>1</b>	<b>0</b>
R/W	R/W	R/W	R/W	R/W	R/W	R/W	R/W	R/W
Reset	0	0	0	0	0	0	0	0

Note: R = Read W = Write X = Indeterminate

Reg Field	Bit Position	R	W	Data	Description
CGoffset	fedcba9876543210	R	W	xxxx	CGROM offset, POR=0



### 3.5 Bank3 (On Screen Display [OSD] Registers)

Table 38 lists the R0(3)- R2(3) character multiplier registers (Read operation).

Table 39 lists the R0(3)–R1(3) Shift Registers (Write operation).

Table 40 lists the R2(3) Attributes Register (Write operation).

**Table 38 Register0–Register2 Read Operation  
R0(3)–R2(3) Character Multiple Registers**

<b>Bit</b>	<b>15</b>	<b>14</b>	<b>13</b>	<b>12</b>	<b>11</b>	<b>10</b>	<b>9</b>	<b>8</b>
R/W	R/W	R/W	R/W	R/W	R/W	R/W	R/W	R/W
Reset	x	x	x	x	x	x	x	x
<b>Bit</b>	<b>7</b>	<b>6</b>	<b>5</b>	<b>4</b>	<b>3</b>	<b>2</b>	<b>1</b>	<b>0</b>
R/W	R/W	R/W	R/W	R/W	R/W	R/W	R/W	R/W
Reset	x	x	x	x	x	x	x	x

Note: R = Read W = Write X = Indeterminate

<b>Reg Name</b>	<b>CGROM Data</b>	<b>Reg Add</b>	<b>Description</b>
cgrom_x2_hi	ffeeddccbbaa9988	R0(3)	High word of double size character R4(3)<6> = 0
cgrom_x3_hi	fffeeedddccbbba		High word of triple size character R4(3)<6> = 1
cgrom_x2_lo	7766554433221100	R1(3)	Low word of double size character R4(3)<6> = 0
cgrom_x3_mid	aa99988877766655		Middle word of triple size character R4(3)<6> = 1
cgrom_x1	fedcba9876543210	R2(3)	Single size character R4(3)<6> = 0
cgrom_x3_lo	5444333222111000		Low word of triple size character R4(3)<6> = 1



**Table 39 Register0–Register1 Write Operation  
R0(3)–R1(3) Shift Registers**

<b>Bit</b>	<b>15</b>	<b>14</b>	<b>13</b>	<b>12</b>	<b>11</b>	<b>10</b>	<b>9</b>	<b>8</b>
R/W	R/W	R/W	R/W	R/W	R/W	R/W	R/W	R/W
Reset	x	x	x	x	x	x	x	x
<b>Bit</b>	<b>7</b>	<b>6</b>	<b>5</b>	<b>4</b>	<b>3</b>	<b>2</b>	<b>1</b>	<b>0</b>
R/W	R/W	R/W	R/W	R/W	R/W	R/W	R/W	R/W
Reset	x	x	x	x	x	x	x	x

Note: R = Read W = Write X = Indeterminate

Reg Name	CGROM Data	Reg Address	Description
current_reg	fedcba9876543210	R0(3)	current line shift register
next/previous_reg	fedcba9876543210	R1(3)	next/previous line shift register

Registers R1(3) and R0(3) must be loaded with video data once every 16 cycles. To support smoothing, register R1(3) must be updated every 16 cycles. The current line register is loaded first, followed by next/previous register during the next cycle. The next/previous register is loaded only if smoothing/fringing attributes are activated for the current character. If neither register is loaded, the space character is displayed. There is no difference between loading 0000h into either register or not loading at all.

**Table 40 Register2 — R2(3) Attributes Register, Write Operation**

<b>Bit</b>	<b>15</b>	<b>14</b>	<b>13</b>	<b>12</b>	<b>11</b>	<b>10</b>	<b>9</b>	<b>8</b>
R/W	R/W	R/W	R/W	R/W	R/W	R/W	R/W	R/W
Reset	x	x	x	x	x	x	x	x
<b>Bit</b>	<b>7</b>	<b>6</b>	<b>5</b>	<b>4</b>	<b>3</b>	<b>2</b>	<b>1</b>	<b>0</b>
R/W	R/W	R/W	R/W	R/W	R/W	R/W	R/W	R/W
Reset	x	x	x	x	x	x	x	x

Note: R = Read W = Write X = Indeterminate

Reg Field	Bit Position	Data	Description
Reserved	f-----	x	No effect



**Z90356 ROM and Z90351 OTP  
64 KWord Television Controller with OSD**

<b>Reg Field</b>	<b>Bit Position</b>	<b>Data</b>	<b>Description</b>
Background color	-edc-----	000	Black
		001	Blue
		010	Green
		011	Cyan
		100	Red
		101	Magenta
		110	Yellow
		111	White
Foreground color NOT Palette Mode	----ba9-----	%D	Same as Background mode
Palette selection Palette Mode	----ba-----	00	Palette0
		01	Palette1
		10	Palette2
		11	Palette3
2nd_underline Palette Mode	-----9-----	1	Second Underline is active
		0	Second Underline is NOT active
1st_underline	-----8-----	1	First Underline is active
		0	First Underline is NOT active
Shift_video	-----7-----	1	Video signal is delayed by 8 pixels
		0	Standard character positioning
Semi-Transparent	-----6-----	1	Semi-Transparent background
		0	Background color defined by "background color" field
Blinking	-----5-----	1	Blinking character
		0	Not blinking character
Italic	-----4-----	1	Italic character
		0	Not italic character
Color_delay	-----32--	00	Character color changes instantly
		01	Color changes with 4 pixels delay
		10	Color changes with 8 pixels delay
		11	Color changes with 12 pixels delay



Reg Field	Bit Position	Data	Description
Shadowing/Fringing	-----10	00	No shadowing (no fringing)
		01	Left shadow
		10	Right shadow
		11	Both shadows (fringing)

**Note:** \*If both the background and foreground colors of a character are set to be the same, the character's background is displayed as transparent.

The attributes register must be loaded 8 cycles after the current line register R0(3) is loaded. Loading the attributes register enables the OSD logic during the next 16 cycles. If the attributes register is not loaded, there is no active OSD, even if the current line register R0(3) is loaded. See Table 41.

**Table 41 Register3 Read Operation  
R3(3) Attributes Register**

<b>Bit</b>	<b>15</b>	<b>14</b>	<b>13</b>	<b>12</b>	<b>11</b>	<b>10</b>	<b>9</b>	<b>8</b>
R/W	R/W	R/W	R/W	R/W	R/W	R/W	R/W	R/W
Reset	x	x	x	x	x	x	x	x
<b>Bit</b>	<b>7</b>	<b>6</b>	<b>5</b>	<b>4</b>	<b>3</b>	<b>2</b>	<b>1</b>	<b>0</b>
R/W	R/W	R/W	R/W	R/W	R/W	R/W	R/W	R/W
Reset	x	x	x	x	x	x	x	x

Note: R = Read W = Write X = Indeterminate

Reg Field	Bit Position	Data	Description
			Same as R2(3)

The data read from the attribute register is a combination of attribute fields from the most recently displayed character and control character codes loaded into the attribute\_data register. Character codes are fetched from Video RAM and must be loaded into the attribute\_data register R3(3). Bit <f> of the attribute\_data register (during a read) indicates whether the most recent character was a control or displayed character. The data read from the attribute\_data register must be directly loaded into attribute register R2(3). Refer to Table 42.



**Table 42 Register3, R3(3) Write Operation  
Attribute Data Register**

<b>Bit</b>	<b>15</b>	<b>14</b>	<b>13</b>	<b>12</b>	<b>11</b>	<b>10</b>	<b>9</b>	<b>8</b>
R/W	R/W	R/W	R/W	R/W	R/W	R/W	R/W	R/W
Reset	x	x	x	x	x	x	x	x
<b>Bit</b>	<b>7</b>	<b>6</b>	<b>5</b>	<b>4</b>	<b>3</b>	<b>2</b>	<b>1</b>	<b>0</b>
R/W	R/W	R/W	R/W	R/W	R/W	R/W	R/W	R/W
Reset	x	x	x	x	x	x	x	x

Note: R = Read W = Write X = Indeterminate

<b>Reg Field</b>	<b>Bit Position</b>	<b>Data</b>	<b>Description</b>
VRAM_data	fedcba9876543210	xxxx	Character code fetched from VRAM

Loading VRAM data into an attribute\_data register initializes a CGROM access cycle. Four clock cycles after the LD instruction, the Z90356 halts for three clock cycles to fetch the data from CGROM and latch it into a CGROM data capture register. After the CGROM data is latched, core operations are resumed. When a control character code is loaded into the attribute\_data register, the CGROM data from address 0000 hex is fetched. Therefore, ZiLOG recommends placing a space character at location 0000 hex in CGROM. Refer to Table 43 through Table 46 for the various VRAM data formats loaded in R3(3).



**Table 43 Display Character Format for Attribute Data Register R3(3)  
OSD Mode Write Operation**

<b>Bit</b>	<b>15</b>	<b>14</b>	<b>13</b>	<b>12</b>	<b>11</b>	<b>10</b>	<b>9</b>	<b>8</b>
R/W	R/W	R/W	R/W	R/W	R/W	R/W	R/W	R/W
Reset	x	x	x	x	x	x	x	x
<b>Bit</b>	<b>7</b>	<b>6</b>	<b>5</b>	<b>4</b>	<b>3</b>	<b>2</b>	<b>1</b>	<b>0</b>
R/W	R/W	R/W	R/W	R/W	R/W	R/W	R/W	R/W
Reset	x	x	x	x	x	x	x	x

Note: R = Read W = Write X = Indeterminate

Reg Field	Bit Position	Data	Description
Control bit	f-----	0	Display character
Background color*	-edc-----	000 Black 001 Blue 010 Green 011 Cyan 100 Red 101 Magenta 110 Yellow 111 White	
Foreground color (Not Palette mode)	-----ba9-----	%D	Same as Background_color
Foreground palette (Palette mode)	-----ba-----	00 Palette 0 (defined in R6(3)<8-6> 01 Palette 1 (defined in R6(3)<b-9> 10 Palette 2 (defined in R6(3)<5-3> 11 Palette 3 (defined in R6(3)<2-0>	
Second underline (Palette mode)	-----9-----	1 Second underline attribute is active 0 Second underline attribute is inactive	
Attribute8	-----8-----	1 Selected attribute (R7(3),<76>) is active 0 Selected attribute (R7(3),<76>) is inactive	
Character code	-----76543210	%DD	Defines the character in CGROM

Note: \*If both the background and foreground colors of a character are set to be the same, the character's background is displayed as transparent.



**Table 44 Control Character Format, OSD Mode Write Operation  
Attribute Data Register R3(3)**

<b>Bit</b>	<b>15</b>	<b>14</b>	<b>13</b>	<b>12</b>	<b>11</b>	<b>10</b>	<b>9</b>	<b>8</b>
R/W	R/W	R/W	R/W	R/W	R/W	R/W	R/W	R/W
Reset	x	x	x	x	x	x	x	x
<b>Bit</b>	<b>7</b>	<b>6</b>	<b>5</b>	<b>4</b>	<b>3</b>	<b>2</b>	<b>1</b>	<b>0</b>
R/W	R/W	R/W	R/W	R/W	R/W	R/W	R/W	R/W
Reset	x	x	x	x	x	x	x	1

Note: R = Read W = Write X = Indeterminate

Reg Field	Bit Position	Data	Description
Control bit	f-----	1	Control character
Reserved	-edcba98-----	x	Reserved—does not affect OSD
Shift_video	-----7-----	1 0	Video signal is delayed by 8 pixels Standard character positioning
Transparent	-----6-----	1 0	Transparent background Background color defined by “background color” field
Blinking	-----5-----	1 0	Blinking character Not blinking character
Italic	-----4-----	1 0	Italic character Not italic character
Color_delay	-----32--	00 01 10 11	Character color changes instantly Color changes with 4 pixels delay Color changes with 8 pixels delay Color changes with 12 pixels delay
Shadowing/ Fringing	-----10	00 01 10 11	No shadowing (no fringing) Left shadow Right shadow Both shadows (fringing)

Smoothing is supported for double size (x2) and triple size (x3) characters only.

At reset, the background color in OSD mode is black. Foreground color, background color, blinking and italic attributes are delayed by 3/4 character. The smoothing attribute is enabled.



**Table 45 Display Character Format, Attribute Data Register R3(3)  
Write Operation CCD Mode**

<b>Bit</b>	<b>15</b>	<b>14</b>	<b>13</b>	<b>12</b>	<b>11</b>	<b>10</b>	<b>9</b>	<b>8</b>
R/W	R/W	R/W	R/W	R/W	R/W	R/W	R/W	R/W
Reset	x	x	x	x	x	x	x	x
<b>Bit</b>	<b>7</b>	<b>6</b>	<b>5</b>	<b>4</b>	<b>3</b>	<b>2</b>	<b>1</b>	<b>0</b>
R/W	R/W	R/W	R/W	R/W	R/W	R/W	R/W	R/W
Reset	x	x	x	x	x	x	x	x

Note: R = Read W = Write X = Indeterminate

<b>Reg Field</b>	<b>Bit Position</b>	<b>Data</b>	<b>Description</b>
Control bit	7-----	0	Display character
Character code	-6543210	%DD	Defines the character in CGROM.



**Table 46 Control Character Format, Attribute Data Register R3(3)  
CCD Mode, Write Operation**

<b>Bit</b>	<b>15</b>	<b>14</b>	<b>13</b>	<b>12</b>	<b>11</b>	<b>10</b>	<b>9</b>	<b>8</b>
R/W	R/W	R/W	R/W	R/W	R/W	R/W	R/W	R/W
Reset	x	x	x	x	x	x	x	x
<b>Bit</b>	<b>7</b>	<b>6</b>	<b>5</b>	<b>4</b>	<b>3</b>	<b>2</b>	<b>1</b>	<b>0</b>
R/W	R/W	R/W	R/W	R/W	R/W	R/W	R/W	R/W
Reset	x	x	x	x	x	x	x	x

Note: R = Read W = Write X = Indeterminate

<b>Reg Field</b>	<b>Bit Position</b>	<b>Data</b>	<b>Description</b>
Control bit	7-----	1	Control character
Transparent	-6-----	1	Transparent background
		0	Background color defined by “background color” field
Blinking	--5-----	1	Blinking character
		0	Not blinking character
Italic	---4-----	1	Italic character
		0	Not italic character
Foreground color	----321-	000	Black
		001	Blue
		010	Green
		011	Cyan
		100	Red
		101	Magenta
		110	Yellow
		111	White
First underline	-----0	1	Underline attribute is active
		0	Underline attribute is inactive

In CCD mode, each character occupies 8 bits (one byte) in VRAM. The CCD characters must be mapped into a 16-bit VRAM data field. The hardware supports compressed character placement in VRAM. Each word in VRAM is represented by HIGH byte and LOW byte. A currently active byte is selected by R4(3)<c>. The format and data representation for both bytes is the same.

There are two possible character formats defined: a “display” character and a “control” character. The code stored in “display” character format defines a character code. The



“control” character defines up to seven attributes of the next character and is presented on screen as a space character.

Combining display and control characters generates a CCD or OSD according to FCC specification. Refer to Table 47.

**Table 47 Register4—R4(3) OSD Control Register**

<b>Bit</b>	<b>15</b>	<b>14</b>	<b>13</b>	<b>12</b>	<b>11</b>	<b>10</b>	<b>9</b>	<b>8</b>
R/W	R/W	R/W	R/W	R/W	R/W	R/W	R/W	R/W
Reset	x	x	x	x	x	x	x	x
<b>Bit</b>	<b>7</b>	<b>6</b>	<b>5</b>	<b>4</b>	<b>3</b>	<b>2</b>	<b>1</b>	<b>0</b>
R/W	R/W	R/W	R/W	R/W	R/W	R/W	R/W	R/W
Reset	x	x	x	x	x	x	x	x

Note: R = Read W = Write X = Indeterminate

<b>Reg Field</b>	<b>Bit Position</b>	<b>R</b>	<b>W</b>	<b>Data</b>	<b>Description</b>
Underline	fe-----	R	W	1x 0x x1 x0	Second underline is active Second underline is inactive First underline is active First underline is inactive
OSD/CCD	--d-----	R	W	1 0	OSD mode CCD mode
CCD_top/btm	---c-----	R	W	1 0	The upper byte in VRAM is used The lower byte in VRAM is used
Italic_shift	----ba98-----	R	W	x	Defines delay of the character
Blink_off/on	-----7-----	R	W	0 1	Blinking character is displayed Blinking character is NOT displayed (hidden)
MPX_bus	-----65-----	R	W	00 01 10 11	x1 character size x2 character size x3 character size Reserved
CGROM scan_line	-----43210	R	W	%D	Defines CGROM addressing

The Underline field must be set by firmware when scan lines that contain underline information are displayed. The underline bits are ANDed with the second and first



underline active fields of data loaded into attribute register R2(3), causing the screen character to be underlined.

The Italic shift field defines a delay of video data. It is used to generate italic characters. The firmware decrements by 1 (the value of the Italic\_shift field) for each consecutive line. The video signal is delayed only for characters that have the R2(3)<4> (“italic”) bit set to 1.

Table 48 lists the bits for the capture register.

**Table 48 Register5, R5(3) Capture Register, Read Operation**

<b>Bit</b>	<b>15</b>	<b>14</b>	<b>13</b>	<b>12</b>	<b>11</b>	<b>10</b>	<b>9</b>	<b>8</b>
R/W	R/W	R/W	R/W	R/W	R/W	R/W	R/W	R/W
Reset	x	x	x	x	x	x	x	x
<b>Bit</b>	<b>7</b>	<b>6</b>	<b>5</b>	<b>4</b>	<b>3</b>	<b>2</b>	<b>1</b>	<b>0</b>
R/W	R/W	R/W	R/W	R/W	R/W	R/W	R/W	R/W
Reset	x	x	x	x	x	x	x	x

Note: R = Read W = Write X = Indeterminate

Reg Field	Bit Position	R	W	Data	Description
Cap_data	fedcba9876543210	R		%xxxx	16-bit captured data
Reserved	fedcba98-----0	R	W		Return 0 No effect
I2C_saddr	-----7654321-		W	%DD	I <sup>2</sup> C Slave interface address

In Read mode, R5(3) returns the 16-bit captured data from the IRIN pin.

In Write mode, the 7-bit I<sup>2</sup>C slave interface address must be put in bit 7-1.

Table 49 lists the bits for the palette control register.



**Table 49 Register6, R6(3) Palette Control Register**

<b>Bit</b>	<b>15</b>	<b>14</b>	<b>13</b>	<b>12</b>	<b>11</b>	<b>10</b>	<b>9</b>	<b>8</b>
R/W	R/W	R/W	R/W	R/W	R/W	R/W	R/W	R/W
Reset	0	0	0	0	0	0	0	0
<b>Bit</b>	<b>7</b>	<b>6</b>	<b>5</b>	<b>4</b>	<b>3</b>	<b>2</b>	<b>1</b>	<b>0</b>
R/W	R/W	R/W	R/W	R/W	R/W	R/W	R/W	R/W
Reset	0	0	0	0	0	0	0	0

Note: R = Read W = Write X = Indeterminate

Reg Field	Bit Position	R	W	Data	Description
Palette	f-----	R	W	1	Palette mode is active
				0	Palette mode is INACTIVE
Underline color	-edc-----	R	W	000	Black
				001	Blue
				010	Green
				011	Cyan
				100	Red
				101	Magenta
				110	Yellow
				111	White
Palette1	----ba9-----	R	W	%D	Same as Underline color
Palette0	-----876-----	R	W	%D	Same as Underline color
Palette3	-----543---	R	W	%D	Same as Underline color
Palette2	-----210	R	W	%D	Same as Underline color

At POR the palette control register is reset to 0.

Table 50 lists the bits for the output palette control register.



**Table 50 Register7, R7(3) Output Palette Control Register**

<b>Bit</b>	<b>15</b>	<b>14</b>	<b>13</b>	<b>12</b>	<b>11</b>	<b>10</b>	<b>9</b>	<b>8</b>
R/W	R/W	R/W	R/W	R/W	R/W	R/W	R/W	R/W
Reset	0	0	0	0	0	0	0	0
<b>Bit</b>	<b>7</b>	<b>6</b>	<b>5</b>	<b>4</b>	<b>3</b>	<b>2</b>	<b>1</b>	<b>0</b>
R/W	R/W	R/W	R/W	R/W	R/W	R/W	R/W	R/W
Reset	0	0	0	0	0	0	0	0

Note: R = Read W = Write X = Indeterminate

<b>Reg Field</b>	<b>Bit Position</b>	<b>R</b>	<b>W</b>	<b>Data</b>	<b>Description</b>
BLANK_delay	fedc-----	R	W		VBlank and SVBLANK delay value—%00—POR condition
Background_on/ off	----b-----	R	W	1 0	Master background is on Master background is off—POR condition
Background_color	-----a98-----	R	W	%D	Defines the color of the Master background (same as the palette)
AttrSelect	-----76-----	R	W	00 01 10 11	1st underline—POR Semi-transparency Blinking CGROM bank select
Smoothing	-----5-----	R	W	0 1	Smoothing logic disabled—POR Smoothing logic enabled
Cursor Write Enable	-----4-----	R	W	0 1	Return “0” Cursor parameters write disabled—POR Cursor parameters write enabled
Palette #	-----3210	R	W	%D	Palette number

At POR the Output palette register is set to 0 for digital output.

Table 15 is the look-up table for the color palettes.



## 4 Instruction Set

The processor instruction set consists of 30 basic instructions. It is optimized for high code density and reduced execution time. Single-cycle instruction execution is possible on most instructions.

The format for Op Codes and addressing modes is provided in the following tables but is normally not required. The assembler removes the burden of hand constructing the instruction format, by translating the mnemonics. System designers can access the instruction format when debugging.

### 4.1 Instruction Summary

The DSP instruction set can be broken down into the following types of instructions:

- Accumulator Modification
- Arithmetic
- Bit Manipulation
- Load
- Logical
- Program Control
- Rotate and Shift

Instruction format mnemonics are in Table 51. Table 52 through Table 58 list other instructions.

**Table 51 Instruction Format Mnemonics**

Mnemonic	Description
A	Address
am	Accumulator Modification
b	RAM Bank
cc	Condition Code
const exp	Constant Expression
d	Destination Address
dest	Destination Value
fm	Flag Modification
op	Op Code
rp	Register Pointer



**Table 51 Instruction Format Mnemonics (Continued)**

<b>Mnemonic</b>	<b>Description</b>
s	Source Address
src	Source Value

**Table 52 Accumulator Modification Instructions**

<b>Mnemonic</b>	<b>Operands</b>	<b>Instruction</b>
ABS	<cc>, A	Absolute Value
CP	A, <src>	Comparison
DEC	<cc>, A	Decrement
INC	<cc>, A	Increment
NEG	<cc>, A	Negate

**Table 53 Arithmetic Instructions**

<b>Mnemonic</b>	<b>Operands</b>	<b>Instruction</b>
ADD	<cc>, A	Add
CP	A, <src>	Compare
SUB	A, <src>	Subtract

**Table 54 Bit Manipulation Instructions**

<b>Mnemonic</b>	<b>Operands</b>	<b>Instruction</b>
CCF	None	Clear Carry Flag
CIEF	None	Clear Interrupt Enable Flag
COPF	None	Clear Overflow Protection Flag
SCF	None	Set Carry Flag
SIEF	None	Set Interrupt Enable Flag
SOPF	None	Set Overflow Protection Flag



**Table 55 Load Instructions**

<b>Mnemonic</b>	<b>Operands</b>	<b>Instruction</b>
LD	<dest>, <src>	Load
POP	<dest>	Pop
PUSH	<src>	Push

**Table 56 Logical Instructions**

<b>Mnemonic</b>	<b>Operands</b>	<b>Instruction</b>
AND	A, <src>	Logical AND
OR	A, <src>	Logical OR
XOR	A, <src>	Logical Exclusive OR

**Table 57 Program Control Instructions**

<b>Mnemonic</b>	<b>Operands</b>	<b>Instruction</b>
CALL	A	Call Procedure
JP	A	Jump
RET	None	Return

**Table 58 Rotate and Shift Instructions**

<b>Mnemonic</b>	<b>Operands</b>	<b>Instruction</b>
RL	<cc>, A	Rotate Left
RR	<cc>, A	Rotate Right
SLL	<cc>, A	Shift Left Logical
SRA	<cc>, A	Shift Right Arithmetic



## 4.2 Instruction Operands

To access the operands for the DSP, use the Register Pointers, Data Pointers, Hardware Registers, Direct Addressing, Immediate Data and Memory. There are nine distinct types of instruction operands. Table 59 and Table 60 list instructions.

**Table 59 Instruction Operand Summary**

Symbolic Name	Syntax	Description
<pregs>	Pn:b	Register Pointer
<dregs>	Dn:b	Data Pointer
<hwregs>	X, Y, PC, SR, EXTn, A, BUS	Hardware Registers
<accind>	@A	Accumulator Indirect
<direct>	<const exp>	Direct Address Expression
<limm>	#<const exp>	Long (16-Bit) Immediate
<simm>	#<const exp>	Short (8-Bit) Immediate Value
<regind>	@Pn:b @Pn:b+ @Pn:b+Loop @Pn:b-Loop	Indirect Addressing of RAM
<memind> @Dn:b	@Dn:b @@Pn:b @@Pn:b+ @@Pn:b+Loop @@Pn:b-Loop	Indirect Addressing of ROM

**Table 60 Instruction Mnemonics/Operands**

#	Instruction	Mnemonic/Operand Representation
1	LD P2:0, #%F2	LD <pregs>, <simm>
2	LD X, @A	LD <hwreg>, <accind>
3	LD Y, #%3CF5	LD <hwreg>, <limm>
4	SUB A, @@P2:0	SUB A, <memind>
5	OR A, @D2:0	OR A, <memind>
6	AD D A, %F2	ADD A, <direct>
7	PUSH D1:1	PUSH <dregs>



< **pregs** > The register pointer mode is used for loading the pointer with the appropriate RAM address. This address references the RAM location that stores the requested data. The pointer can also be used to store 8-bit data when used as a temporary register. The pointers are connected to the lower 8 bits of the D-bus. Instruction 1 loads Pointer 2, RAM Bank0 with the value F2H.

< **regind** > The register indirect mode is used for indirect access to RAM. As noted in Instruction 2, the register indirect address method is used to get the operand to multiply it with the accumulator.

< **dregs** > The data-pointer mode is used as an indirect addressing method similar to @P2:0. The data pointers access the lower 16 bits of each RAM bank. Instruction 8 uses indirect addressing to PUSH information onto the stack.

< **memind** > Pointer or data registers can be used to access program memory. Both are commonly used to reference program memory. Instructions 5 and 6 display this addressing method. Either pointer is automatically incremented to assist in transferring sequential data.

< **accind** > Another method of indirect addressing is using the accumulator to store the address. Instruction 3 describes how to use this method.

< **direct** > The absolute RAM address is used in the direct mode. A range between 0 and 511 (000H to 1FFH) is allowed. The accumulator is used in conjunction with this method as a source or destination operand. Instruction 7 displays the accumulator as the destination.

< **limm** > This instruction indicates a long immediate load. A 16-bit word can be copied directly from the operand into the specified register or memory. Instruction 4 uses this method.

< **simm** > This instruction can only be used for immediate transfer of 8-bit data in the operand to the specified RAM pointer.

### 4.3 Instruction Format

The instruction format that specifies to the processor the action to be taken consists of the Op Code, destination, source, and other special bits. The assembler makes this operation transparent by providing mnemonics. Occasionally, the instruction format and development code can assist in debugging. Examples to clarify the various instruction formats and explain how specific bit patterns are developed and evaluated are provided below.

Most instructions require one 16-bit word containing the information necessary for the processor to execute the instruction correctly. This process requires one clock cycle for execution. Immediate addressing, immediate operands, JUMP and CALL instructions



require two 16-bit words (two clock cycles). Each instruction type has a unique Op Code and format to differentiate various instructions. Different operations also have unique formats.

The variables *a*, *op*, *b*, *d*, *s*, *cc*, *am*, *fm*, *rp* are used in the instruction format to depict bits determined by the active instruction.

### ADDITION and INC Formats

The Op Code and format for an instruction differ to allow the processor to differentiate between the instructions. For example, the ASSITION instruction requires that two operands be defined in the instruction.

ADD A, <regind>

15	14	13	12	11	10	9	8	7	6	5	4	3	2	1	0
1	0	0	0	0	0	1	1	0	0	0	0	S	S	S	S
Op Code							RAM Bank	Condition Code				Modification Code			

The INC (increment) instruction requires that a condition and modification code be specified.

INC A

15	14	13	12	11	10	9	8	7	6	5	4	3	2	1	0
1	0	0	1	0	0	0	0	0	1	0	0	1	0	1	0
Op Code							Condition Code				Modification Code				

### INC and SLL Formats

The INC and SLL instructions have the same Op Code with an accumulator modification format. The most recent four bits, the modification code, determine the type of operation the accumulator performs.

INC A

15	14	13	12	11	10	9	8	7	6	5	4	3	2	1	0
1	0	0	1	0	0	0	0	0	0	0	0	0	0	1	0
Op Code							Condition Code				Modification Code				

SLL A



15	14	13	12	11	10	9	8	7	6	5	4	3	2	1	0
1	0	0	1	0	0	0	0	0	0	0	0	0	0	1	1
Op Code							Condition Code					Modification Code			

#### 4.4 Instruction Bit Codes

The values in a series of bits in a register form patterns called bit codes. Types of bit codes include the following:

- Condition Codes
- Accumulator Modification Code
- Flag Modification Codes
- Source/Destination Field Designators
- Register Pointer/Data Pointer

The following tables list the options available and their corresponding instructions.

##### Condition Codes

Table 61 lists the condition codes that are used in accumulator modification, CALL, and JUMP instructions.

**Table 61 Condition Code Bits**

Bit Code	Mnemonic Code Value	Condition Code Value	Condition Code
00000	F		False
00001			Unused
00010	NU0	UI0 is set to 0	Not User Zero
00011	NU1	UI1 is set to 0	Not User One
00100	NC	C is set to 0	No Carry
00101	NZ	Z is set to 0	Not Zero (Not Equal)
00110	NOV	OV is set to 0	No Overflow
00111	PL	N is set to 0	Plus (Not Negative)
01xxx			Unused



**Table 61 Condition Code Bits (Continued)**

Bit Code	Mnemonic Code Value	Condition Code Value	Condition Code
10000	T		True
10001			Unused
10010	U0	UI0 is set to 1	User Zero
10011	U1	UI1 is set to 1	User One
10100	C	C is set to 1	Carry
10101	Z	Z is set to 1	Zero (Equal)
10110	OV	OV is set to 1	Overflow
10111	MI	N is set to 1	Minus (Negative)
11xxx			Unused

### Accumulator Modification Codes

Accumulator modification codes determine the type of modification made to the value in the accumulator. See Table 62. Condition codes are also used with CALL, and JUMP instructions.

**Table 62 Accumulator Modification Bits**

Bit Code	Mnemonic	Operation
0000	RR	Rotate Right
0001	RL	Rotate Left
0010	SR	Shift Right
0011	SL	Shift Left
0100	INC	Increment
0101	DEC	Decrement
0110	NEG	Negate
0111	ABS	Absolute

### Flag Modification Codes

Flag modifications initialize or set/reset bits to accommodate interrupts, overflows, and carries. See Table 63.



**Table 63 Flag Modification Bits**

Bit Code	Mnemonic	Operation	Flag	Value
xx10	CCF	Clear Carry	C	0
xx11	SCF	Set Carry	C	1
x1x0	CIEF	Clear Interrupt Enable	IE	0
x1x1	SIEF	Set Interrupt Enable	IE	1
1xx0	COPF	Clear Overflow Protection	OP	0
1xx1	SOPF	Set Overflow Protection	OP	1

### Source/Destination Field Designators

Register pointers and data pointers provide convenient access to data. The pointers are a source or destination field in instructions. Specific bit codes are listed in Table 64. The register pointer offers optional incrementing or decrementing. This option is specified by the following instruction:

```
LD A, @P2:1+
```

**Table 64 Register Pointer/ Data Pointer Bits**

Bit Code	Mnemonic
00xx	NOP
01xx	+1
10xx	-1/loop
11xx	+1/loop
xx00	P0:0 or P0:1
xx01	P1:0 or P1:1
xx10	P2:0 or P2:1
0011	D0:0 or D0:1
0111	D1:0 or D1:1
1011	D2:0 or D2:1
1111	D3:0 or D3:1



Data pointers are automatically incremented when accessing program memory (for example, LD A, @D0:0) and do not require an incrementing option. Code in xx11 format is designated for a data pointer when source or destination format is used.

Additional source or destination designators include the other hardware registers provided by the processor. To determine if a data pointer, register pointer or a register is used as a source or destination is discussed in the next section.

Table 65 lists the bit codes for mnemonic register names.

**Table 65 Register Bits**

Bit Code	Mnemonic
0000	Bus
0001	X
0010	Y
0011	A
0100	SR
0101	STACK
0110	PC
0111	Reserved
1000	EXT0
1001	EXT1
1010	EXT2
1011	EXT3
1100	EXT4
1101	EXT5
1110	EXT6
1111	EXT7

#### 4.5 Instruction Format Examples

Refer to the following examples indicating how bit codes are used in an instruction format.



**Instruction Format**

15	14	13	12	11	10	9	8	7	6	5	4	3	2	1	0
op op op op op op op							cc cc cc cc cc					am am am am			
Op Code							Condition Code					ACC Modification			

**Accumulator Modification Format**

15	14	13	12	11	10	9	8	7	6	5	4	3	2	1	0
op op op op op op op							cc cc cc cc cc					am am am am			
Op Code							Condition Code					ACC Modification			

**Notes:**

1. The Variables *a*, *op*, *b*, *d*, *s*, *cc*, *am*, *fm*, *rp* are used in the instruction format to depict bits determined by the instruction.
2. The General Instruction Format requires an Op Code, RAM bank bit, destination and source addresses. For example, LD A, @P2:1+

**Load Instruction Format**

15	14	13	12	11	10	9	8	7	6	5	4	3	2	1	0
0 0 0 0 0 0 1							1	0 0 1 1				0 1 1 0			
Op Code							RAM Bank	Destination				Source			

The Op Code (0000001) provides a unique signature for the LD command. The processor uses this signature to determine the instruction format. The RAM bank bit is high (equal to 1) because of the instruction definition  $b=1$  ( $P_n:b$ ). The destination bit code is 0011 which corresponds to the accumulator. The source 0110 corresponds to the +1 option and P2:0 or P2:1. The RAM bank bit indicates that the processor loaded the accumulator with the operand designated by Pointer 2 Bank1 (P2:1).

Source and destination fields can be accessed from the register pointers, data pointers, or registers. The Op Code specifies the type of source and destination. An Op Code of 0000101 specifies that the source is an indirect address to program memory (@@P0.0 or @D0:0) and the destination is a register.

**Instruction Format Listing**

Instruction formats and applicable instructions are listed in Table 66 through Table 72.



**Notes:**

- Several instructions provide various addressing modes to obtain operands; therefore, the same instruction can have several different formats depending on the addressing mode.
- The variables *a*, *op*, *b*, *d*, *s*, *ce*, *am*, *fm*, *rp* are used in the instruction format to depict bits determined by the specific instruction used.

**General Instruction Format**

15	14	13	12	11	10	9	8	7	6	5	4	3	2	1	0
op	op	op	op	op	op	op	b	d	d	d	d	s	s	s	s
Op Code							RAM Bank	Destination				Source			

**Table 66 General Instruction Format**

Mnemonic	Operands	Bit Code	Hex
ADD	A, @P0:0	1000001 0 0000 0000	8200
AND	A, D11	1100110 1 0000 0111	AB07
CP	A,X	0110000 0 0000 0001	6001
LD	A,P	0000000 0 0011 0111	0037
POP	X	0000000 0 0001 0101	0015
PUSH	D0:0	0000001 0 0101 0011	0253
RET		0000000 0 0110 0101	0065
SUB	A,@D1:1	0010101 1 0000 0111	2B07
XOR	A,P2:0	1111001 0 0000 0010	F202

**Accumulator Modification Format**

15	14	13	12	11	10	9	8	7	6	5	4	3	2	1	0
op	op	op	op	op	op	op	cc	cc	cc	cc	cc	am	am	am	am
Op Code							Condition Code					ACC Modification			



**Table 67 Accumulator Modification Format**

Mnemonic	Operands	Bit Code	Hex Representation
ABS	Z, A	1001000 10101 0111	9157
DEC	A	1001000 00000 0101	9005
INC	NZ, A	1001000 00101 0100	9054
NEG	A	1001000 00000 0110	9006
RR	NU0, A	1001000 00010 0000	9020
RL	PL, A	1001000 00111 0001	9071
SLL	C, A	1001000 10100 0011	9143
SRA	U1, A	1001000 10011 0010	9132

**Flag Modification Format**

15	14	13	12	11	10	9	8	7	6	5	4	3	2	1	0
op	op	op	op	op	op	op	cc	cc	cc	cc	cc	fm	fm	fm	fm
Op Code							Condition Code					Flag Modification			

**Table 68 Flag Modification Format**

Mnemonic	Bit Code	Hex Representation
CCF	1001010 00000 0010	9402
CIEF	1001010 00000 0100	9404
COPF	1001010 00000 1000	9408
SCF	1001010 00000 0011	9403
SIEF	1001010 00000 0101	9405
SOPF	1001010 00000 1001	9409

**Direct Internal Addressing Format**

15	14	13	12	11	10	9	8	7	6	5	4	3	2	1	0
op	op	op	op	op	op	op	a	a	a	a	a	a	a	a	a
Op Code							9-Bit Internal Address								



**Table 69 Direct Internal Addressing Format**

Mnemonic	Operands	Bit Code	Hex Representation
ADD	A, %FF	1000011 011111111	86FF
AND	A, 255	1010011 011111111	A6FF
CP	A, 255	0110011 011111111	66FF
LD		0000111 000010010	0E12

**Short Immediate Addressing Format**

15	14	13	12	11	10	9	8	7	6	5	4	3	2	1	0
op	op	op	op	op	rp	rp	rp	a	a	a	a	a	a	a	a
Op Code					Register Pointer			8-Bit Immediate Address/Data							

**Table 70 Short Immediate Addressing Format**

Mnemonic	Operands	Bit Code	Hex Representation
LD	P1:1, #%FA	00011 101 11111010	1DFA

**Long Immediate Addressing Format**

15	14	13	12	11	10	9	8	7	6	5	4	3	2	1	0
op	op	op	op	op	op	op	b	d	d	d	d	s	s	s	s
Op Code							RAM Bank	Destination				Source			
15	14	13	12	11	10	9	8	7	6	5	4	3	2	1	0
a	a	a	a	a	a	a	a	a	a	a	a	a	a	a	a
16-Bit Address/Data															



**Table 71 Long Immediate Addressing Format**

Mnemonic	Operands	Hex Representation
ADD	A, #%1234	8800 1234
AND	A, #% 26A4	A800 26A4
LD	X, #%6FFC	0810 6FFC
PUSH	#%C32C	0850 C32C
SUB	A, #%2444	2800 2444
XOR	A,#%AFC2	E800 AFC2

**JUMP, CALL Format**

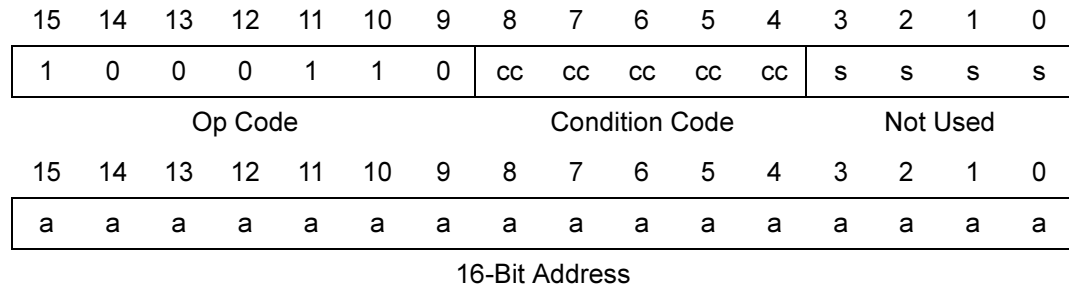

**Table 72 Jump, Call Format**

Mnemonic	Operands	Hex Representation
CALL	END	4800 0004
JP	U1, END	4D30 0004

### 4.6 Instruction Timing

The DSP can be executed with single cycle instruction using the independent data memory and program memory buses offered by the modified Harvard architecture and pipeline instruction. This method provides overlapping of instruction fetch and execution cycles. Figure 27 illustrates the execution sequence. The first instruction takes two clock cycles to execute; subsequent executions occur in a single cycle. All instruction fetch cycles have the same machine timing regardless of whether external or internal memory is used. Because the DSP contains a two-level pipeline, the JUMP and CALL instructions do not disrupt the execution process

In two-byte instructions, the second byte is being fetched while the first byte is executing. Because the processor knows that the instruction is a JUMP or CALL, the second byte is transferred to the program counter and the correct address is fetched into the pipeline. There is no disruption or pipeline flushing. The pipeline flow is affected when the program counter is the destination for a load. Because the load (LD) instruction is a single word instruction, the next instruction is fetched during load execution. To compensate for the instruction in the pipeline, that instruction is executed as a NOP.

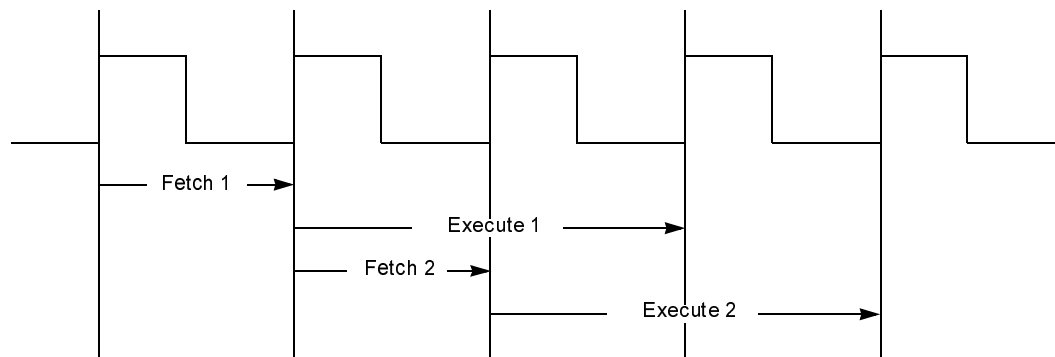

Figure 27 Pipeline Execution

## 4.7 Instruction Op Codes

Table 73 summarizes essential information about the instruction set.

Table 73 Instruction Op Codes

Inst	Description	Op Code	Synopsis	Operands	Words	Cycles	Examples
ABS	Absolute Value	1001000	ABS[<cc>,<src>	<cc>,A	1	1	ABS NC, A
		1001000		A	1	1	ABS A
ADD	Addition	1001001	ADD<dest>,<src>	A,<pregs>	1	1	ADD A, P0:0
		1000001		A,<dregs>	1	1	ADD A, D0:0
		1000100		A,<limm>	2	2	ADD A, #%1234
		1000101		A,<memind>	1	3	ADD A, @@P0:0
		1000011		A,<direct>	1	1	ADD A, %F2
		1000001		A<regind>	1	1	ADD A, @P1:1
		1000000		A,<hwregs>	1	1	ADD A, X



Table 73 Instruction Op Codes (Continued)

Inst	Description	Op Code	Synopsis	Operands	Words	Cycles	Examples
AND	Bitwise AND	1011001	AND <dest>, <src>	A, <pregs>	1	1	AND A, P2:0
		1010001		A, <dregs>	1	1	AND A, D0:1
		1010100		A, <limm>	2	2	AND A, #%1234
		1010101		A, <memind>	1	3	AND A, @@P1:0
		1010001		A, <direct>	1	1	AND A, %2C
		1010001		A, <regind>	1	1	AND A, @1:2+LOOP
		1010000		A, <hwregs>	1	1	AND A, EXT3
CALL	Subroutine Call	0010100	CALL <cc>, <address>	<cc>, <direct>	2	2	CALL sub1
		0010100		<direct>	2	2	CALL Z, sub2
CCF	Clear Carry Flag	1001010	CCF	None	1	1	CCF
CIEF	Clear Carry Flag	1001010	CIEF	None	1	1	CIEF
COPF	Clear OP Flag	1001010	COPF	None	1	1	COPF
CP	Comparison		CP<src1>, <src2>				
		0111001		A, <pregs>	1	1	CP A, P0:0
		0110001		A, <dregs>	1	1	CP A, D3:1
		0110101		A, <memind>	1	3	CP A, @@P0:0
		0110011		A, <direct>	1	1	CP A, %FF
		0110001		A, <regind>	1	1	CP A, @P2:1+
		0110000		A, <hwregs>	1	1	CP A, STACK
		0110100		A, <limm>	2	2	CP A, #%FFCF
DEC	Decrement	1001000	DEC [<cc>.,] <dest>	<cc>, A	1	1	DEC NZ, A
		1001000		A	1	1	DEC A
INC	Increment	1001000	INC [<cc>.,] <dest>	<cc>, A	1	1	INC PL, A
		1001000		A	1	1	INC A
JP	Jump	0100110	JP [<cc>.,] <address>	<cc>, <direct>	2	2	JP NIE, Label
		0100110		<direct>	2	2	JP Label



Table 73 Instruction Op Codes (Continued)

Inst	Description	Op Code	Synopsis	Operands	Words	Cycles	Examples
LD	Load Destination with Source	0000000	LD <dest>, <src>	A, <hwregs>	1	1	LD A, X
		0000001		A, <dregs>	1	1	LD A, D0:0
		0001001		A, <pregs>	1	1	LD A, P0:1
		0000001		A, <regind>	1	1	LD A, @P1:1
		0000101		A, <memind>, <memind>	1	3	LD A, @D0:0
		0000011		A, <direct>	1	1	LD A, 124
		0000111		<direct>, A	1	1	LD 124, A
		0000100		<dregs>, <hwregs>	1	1	LD D0:0, EXT7
		0001100		<pregs>, <simm>	1	1	LD P1:1, #%FA
		0001010		<pregs>, <hwregs>	1	1	LD P1:1, EXT1
		0000110		<regind>, <limm>	1	1	LD @P1:1, #%1234
		0000010		<regind>, <hwregs>	1	1	LD @PM+, X
		0001001		<hwregs>, <pregs>	1	1	LD Y, P0:0
		0000001		<hwregs>, <dregs>	1	1	LD SR, D0:0
		0000100		<hwregs>, <limm>	2	2	LD PC, #%1234
		0100101		<hwregs>, <accind>	1	3	LD X, @A
		0000101		<hwregs>, <memind>	1	3	LD Y, D0:0
		0000001		<hwregs>, <regind>	1	1	LD A, @P0:0-LOOP
		0000000		<hwregs>, <hwregs>	1	1	LD X, EXT6
						When <dest> is <hwregs>, <dest> cannot be P. When <dest> is <hwregs> and <src> is <hwregs>, <dest> cannot be EXTn if <src> is EXTn, <dest> cannot be X if <src> is X, <dest> cannot be SR if <src> is SR. When <src> is <accind> <dest> cannot be A.	



Table 73 Instruction Op Codes (Continued)

Inst	Description	Op Code	Synopsis	Operands	Words	Cycles	Examples
NEG	Negate	1001000	NEG <cc>, A	<cc>, A	1	1	NEG NZ,A
		1001000		A	1	1	NEG A
NOP	No Operation	0000000	NOP	None	1	1	NOP
OR	Bitwise OR		OR <dest>, <src>				
		1101001		A, <pregs>	1	1	OR A, P0:1
		1100001		A, <dregs>	1	1	OR A, D0:1
		1100100		A, <limm>	2	2	OR A, #202
		1100101		A, <memind>	1	3	OR A, @@P2:1+
		1100011		A, <direct>	1	1	OR A, %2C
		1100001		A, <regind>	1	1	OR A, @P1:0-LOOP
		1100000		A, <hwregs>	1	1	OR A, EXT6
POP	Pop a Value from the Stack	0001010	POP <dest>	<pregs>	1	1	POP P0:0
		0000100		<regs>	1	1	POP D0:1
		0000010		<regind>	1	1	POP @P0:0
		0000000		<hwregs>	1	1	POP A
PUSH	Push a Value onto the Stack	0001001	PUSH <src>, <pregs>		1	1	PUSH P0:0
		0000001		<dregs>	1	1	PUSH D0:1
		0000001		<regind>	1	1	PUSH @P0:0
		0000000		<hwregs>	1	1	PUSH BU.S
		0000100		<limm>	2	2	PUSH #2345
		0100101		<accind>	1	3	PUSH @A
		0000101		<memind>	1	3	PUSH @@P0:0
RET	Return from Subroutine	0000000	RET	None	1	2	RET
RL	Rotate Left	1001000	RL <cc>, A	<cc>, A	1	1	RL NZ, A
		1001000		A	1	1	RL A
RR	Rotate Right	1001000	RR <cc>, A	<cc>, A	1	1	RR C, A
		1001000		A	1	1	RR A



Table 73 Instruction Op Codes (Continued)

Inst	Description	Op Code	Synopsis	Operands	Words	Cycles	Examples
SCF	Set C Flag	1001010	SCF	None	1	1	SCF
SIEF	Set IE Flag	1001010	SIEF	None	1	1	SIEF
SLL	Shift Left Logical	1001000	SLL	[<cc>,) A	1	1	SLL NZ, A
		1001000		A	1	1	SLL A
SOPF	Set OP Flag	1001010	SOPF	None	1	1	SOPF
SRA	Shift Right	1001000	SRA <cc>, A	<cc>, A	1	1	SRA NZ, A
	Arithmetic	1001000		A	1	1	SRA A
SUB	Subtract	0011001	SUB <dest>, <src>	A, <pregs>	1	1	SUB A, P1:1
		0010011		A, <dregs>	1	1	SUB A, D0:1
		0010100		A, <limm>	2	2	SUB A, #%2C2C
		0010101		A, <memind>	1	3	SUB A, @D0:1
		0010011		A, <direct>	1	1	SUB A, %15
		0010001		A, <regind>	1	1	SUB A, @P2:0-LOOP
		0010000		A, <hwregs>	1	1	SUB A, STACK
XOR	Bitwise Exclusive OR		XOR <dest>, <src>				
		1111001		A, <pregs>	1	1	XOR A, P2:0
		1110001		A, <dregs>	1	1	XOR A, D0:1
		1110100		A, <limm>	2	2	XOR A, #%3933
		1110001		A, <memind>	1	3	XOR A, @P2:1+
		1110011		A, <direct>	1	1	XOR A, %2F
		1110001		A, <regind>	1	1	XOR A, @P2:0
		1110000		A, <hwregs>	1	1	XOR A, BUS

### Instruction Descriptions

The DSP instruction set consists of 30 basic instructions, optimized for high-code density and reduced execution time. Single-cycle instruction execution is possible because of the pipeline and other architectural features. Table 74 contains a description for each instruction.



**Table 74 Instruction Descriptions**

<b>Mnemonic</b>	<b>Mnemonic Expansion</b>
Instruction Operands	Lists the types of addressing methods for a specific instruction (ABS A or ABS <cc>, A).
Instruction Format	Displays instruction format for register indirect addressing.
Operation	Displays operation sequence.
Affected Flags	Lists flags affected by operation.
Description	Describes the instruction operation.
Examples	A simple example displays the instruction operation and how the registers are affected. The example includes initialization, instruction and result. Also includes cycles and instruction length.

**Note:** Each Assembly Instruction includes an example for each addressing mode available for the specific instruction.

The mnemonics listed in Table 75 are used in the instruction format.

**Table 75 Instruction Format Mnemonics**

<b>Mnemonic</b>	<b>Description</b>	<b>Mnemonic</b>	<b>Description</b>
A	Address	dest	Destination Value
am	Accumulator Modification	fm	Flag Modification
b	RAM Bank	op	Op Code
cc	Condition Code	rp	Register Pointer
const exp	Constant Expression	s	Source Address
d	Destination Address	src	Source Value



**ABS**

**Absolute Value**

**ABS**

**Instruction Word**

15	14	13	12	11	10	9	8	7	6	5	4	3	2	1	0				
1	0	0	1	0	0	0	cc	cc	cc	cc	cc	0	1	1	1				
							Op Code					Condition Code					ACC Modification		

**Syntax**

ABS <cc>, A

ABS A

**Operation**

If ACC < 0 then -(ACC) -> ACC

Flags: N: Set if the accumulator has 800000H (see below).

**Description**

If the contents of the accumulator are determined to be less than 0 (a negative number), the absolute value of the accumulator is calculated (accumulator replaced by its two's complement value). Using the condition code provides an additional method to evaluate a status flag before the absolute value of the accumulator is calculated.

**Note:** If the accumulator contains 800000H, the ABS A instruction stores the value of the two's complement at address 800000H and sets the Overflow and Negative status bits. There is no overflow protection.

**Example**

ABS A

Initialization: Accumulator contains FFEB00H  
SR contains 0000H

Instruction: ABS A

Result: Accumulator contains 001500H  
SR contains 1000H

This example uses one word of memory and executes in one machine cycle. Because the value in the accumulator is less than zero, the two's complement is performed and the result is placed in the accumulator ABS ( FFEBH ) = 001500H. The carry bit is set.



### Example

ABS <CC>, A

Initialization: Accumulator contains 456400H

Instruction: ABS MI, A

Result: Accumulator contains 456400H

This example uses one word of memory and executes in one machine cycle. The condition code (negative bit) is not set because the accumulator value is positive; therefore, the instruction is not executed.





Initialization: Accumulator contains 123456H  
P0:0 contains 4DH  
RAM Bank1: 4DH contains 8746H

Instruction: ADD A, @P0:0

Result: A contains 997A56H  
@P0:0 contains 746H

This example uses one word of memory and executes in one machine cycle. The pointer P0:0 contains the RAM register location (4DH). The contents of RAM register 4DH are added to the accumulator to obtain the sum (874600H + 123456H = 997A56H). The sum is contained in the accumulator and the pointer is left unchanged. The direct addressing equivalent is ADD A, %4D or ADD A, 77 (4DH = 77 decimal).

### Example

ADD A, <memind>

Initialization: Accumulator contains 123400H  
P0:0 contains 21H  
RAM Bank0: 21H contains 247AH  
ROM Address: 247AH contains 0C12H

Instruction: ADD A, @@P0:0

Result: A contains 1E4600H  
P0:0 contains 21H  
RAM Bank0: 21H contains 247BH

This example uses one word of memory and executes in three machine cycles. The pointer P0:0 contains the RAM register location (21H). The contents of this register have a ROM address. This address refers to the ROM data placed in the specified accumulator by an AND instruction  $123400H + 0C1200H = 1E4600H$ . When memory indirect addressing is used, the ROM address is automatically incremented. to provide a convenient method of accessing sequential data. Using ADD A, @@P0:0+ performs the same operation and also increments the P0:0 content to 22H.

### Example

ADD A, <limm>

Initialization: Accumulator contains 123400H

Instruction: ADD A, #%0C12

Result: A contains 1E4600H

This example uses two words of memory and executes in two machine cycles. The immediate operand 0C12H is added to the accumulator to obtain the sum  $123400H + 0C1200H = 1E4600H$ .

### Example

```
ADD A, <hwregs>
```

Initialization: Accumulator contains 23400H  
Register X contains 0C12H

Instruction: ADD A, X

Result: A contains 1E4600H

This example uses one word of memory and executes in one machine cycle. The contents of register X are added to the accumulator to obtain the sum.  $123400H + 0C1200H = 1E4600H$ . All hardware registers can transfer from <hwregs>.

### Example

```
ADD A, <direct>
```

Initialization: Accumulator contains 123400H  
RAM Bank0: F3H contains 0C12H

Instruction: ADD A, %F3

Result: A contains 1E4600H

This example uses one word of memory and executes in one machine cycle. Register F3H is added to the accumulator to obtain the sum.  $123400H + 0C1200H = 1E4600H$ . An equivalent instruction is ADD A, 243 (F3H = 243 decimal).

### Example

```
ADD A, <pregs>
```

Initialization: Accumulator contains 123400H  
P0:0 contains 56H

Instruction: ADD A, P0:0

Result: Accumulator contains 128A00H

This example uses one word of memory and executes in one machine cycle. The contents of the pointer register P0:0 is added to the accumulator.  $123400H + 005600H = 128A00H$ . The Pointer Register is connected to the lower 8 bits of the D-bus. The D-bus is connected to the upper 16-bits of the P-bus. This causes the pointer register operand to become 005600H before being added to the accumulator.



### Example

ADD A, <dregs>

Initialization: Accumulator contains 123400H  
D0: 1 contains 8746H

Instruction: ADDA, D0 : 1

Result: A contains 997A00H  
D0: 1 contains 8746H

This example uses one word of memory and executes in one machine cycle. The contents of the data pointer D0 : 1 are added to the accumulator. The sum is contained in the accumulator and the pointer is left unchanged. The data pointer contains 8746H.



**AND**

**BITWISE AND**

**AND**

**Instruction Word**

15	14	13	12	11	10	9	8	7	6	5	4	3	2	1	0	
1	0	1	1	1	0	0	b	0	0	0	0	s	s	s	s	
							Op Code	RAM Bank	Destination				Source			

**Syntax**

- AND A, <regind>
- AND A, <memind>
- AND A, <limm>
- AND A, <hwregs>
- AND A, <direct>
- AND A, <pregs>
- AND A, <dregs>
- AND A, <simm>

**Operation**

<accumulator>. AND.<source> -> <accumulator>

- Flags: N: Set if accumulator result is less than 0.
- Z: Set if accumulator result is 0.

**Description**

Data is stored in the specified accumulator by an AND instruction. The lower eight bits of the accumulator are cleared when this instruction is executed.

**Example**

AND A, <regind>

Initialization: Accumulator contains 123456H  
 P0A contains 45H  
 RAM Bank1: 45H contains 8746H

Instruction: AND A, @P0:1



Result: Accumulator contains 020400H

This example uses one word of memory and executes in one machine cycle. The data in RAM Bank1, referenced by RAM pointer 0, is stored in the specified accumulator using an AND instruction  $123456H.AND.874600H = 020400H$ .

### Example

```
AND A, <memind>
```

Initialization: Accumulator contains 123400H  
P0:0 contains 45H  
RAM Bank0: 45H contains 047AH  
ROM Address: 047AH contains 8746H

Instruction: AND A, @@P0:0

Result: A contains 020400H  
P0:0 contains 45H  
RAM Bank0: 45H contains 247BH

This example uses one word of memory and executes in three machine cycles. The pointer P0:0 contains the RAM register location (45H). The contents of this register has a ROM address. This address refers to the ROM data that is placed in the specified accumulator by an AND instruction  $123400H.AND.874600H = 020400H$ . With memory-indirect addressing, the ROM address is automatically incremented. This provides a convenient method to access sequential data. Using AND A, @@P0:0+ performs the same operation and also increments the P0:0 content to 46H.

### Example

```
AND A, <limm>
```

Initialization: Accumulator contains 362400H

Instruction: AND A, #1234

Result: Accumulator contains 122400H

This example uses two words of memory and executes in two machine cycles. The immediate operand 1234H and an accumulator address are processed with an AND instruction to produce the result,  $362400H.AND.123400H = 122400H$ .

### Example

```
AND A, <simm>
```

Initialization: Accumulator contains 123456H



Instruction: AND A, #%1F

Result: Accumulator contains 001400H

This example uses one word of memory and executes in one machine cycle. The data in the immediate field and the contents of the accumulator are processed with an AND instruction.  $123456H \cdot AND \cdot 001F00H = 001400H$ .

### Example

AND A, <hwregs>

Initialization: Accumulator contains 123400H  
Register X contains 0C12H

Instruction: AND A, X

Result: A contains 001000H

This example uses one word of memory and executes in one machine cycle. Use an AND instruction to send the contents of Register X to the accumulator to obtain the result  $123400H \cdot AND \cdot 0C1200H = 001000H$ . All hardware registers can transfer from <hwregs>.

### Example

AND A, <direct>

Initialization: Accumulator contains 123400H  
RAM Bank0: F3H contains 0C12H

Instruction: AND A, %F3

Result: A contains 001000H

This example uses one word of memory and executes in one machine cycle. Use an AND instruction to send Register F3H to the accumulator to obtain the result  $123400H \cdot AND \cdot 0C1200H = 001000H$ . An equivalent instruction is AND A, 243 (F3H = 243 decimal).

### Example

AND A, <pregs>

Initialization: Accumulator contains 123400H  
P0:0 contains 56H

Instruction: AND A, P0:0

Result: Accumulator contains 001400H



This example uses one word of memory and executes in one machine cycle. Use an AND instruction to send the contents of the pointer register P0:0 to the accumulator 123400H.  $AND.005600H = 001400H$ . The Pointer Register is connected to the lower 8 bits of the D-bus. The D-bus is connected to the upper 16 bits of the P-bus. This action changes the pointer register operand to 005600H before being added to the accumulator.

### **Example**

AND A, <dregs>

Initialization: Accumulator contains 123400H  
D0:1 contains 2645H

Instruction: AND A, 00:0

Result: Accumulator contains 020400H

This example uses one word of memory and executes in one machine cycle. The data register, D0:0, references the operand 2645H. Use an AND instruction to send this data register to the accumulator to produce the result  $123400H.AND.2645H = 020400H$ .





Result: PC contains F234H  
Stack Level 0 contains 1FFDH  
Stack Level 1 contains 0025H

This example uses two words of memory and executes in two machine cycles. The call to the subroutine FFT2 places PC+2 (1 FFDH) on the stack. All information currently on the stack is pushed up the stack. The subroutine address is then placed in the PC register. The processor executes the next instruction addressed by the PC, the FFT2 subroutine.

### Example

```
CALL <cc>, <direct>
```

Initialization: PC contains 1FFBH  
FFT2 subroutine address contains F234H  
Stack Level 0 contains 0025H  
UO (User Zero Bit) contains 1

Instruction: CALL UO, FFT2

Result: PC = F234H  
Stack Level 0= 1FFDH  
Stack Level 1= 0025H

This example uses two words of memory and executes in two machine cycles. The condition code UO is tested by the processor before executing the CALL instruction. Because the UO bit is enabled, the CALL routine is executed exactly like the example above. The condition code UO is input to the processor that determines if subroutine FFT2 is used. Another CALL instruction can determine if another subroutine, FFT1, is used.

### Example

```
CALL <direct>
```

Initialization: PC contains 1FFBH  
FFT2 subroutine address contains F234H  
Stack Level 0 contains 0025H

Instruction: CALL FFT2

Result: PC contains F234H  
Stack Level 0 contains 1FFDH  
Stack Level 1 contains 0025H

This example uses two words of memory and executes in two machine cycles. The call to the subroutine FFT2 places PC+2 (1 FFDH) on the stack. All information currently on



the stack is pushed up the stack. The subroutine address is then placed in the PC register. The processor executes the next instruction addressed by the PC, the FFT2 subroutine.



**CCF**

**CLEAR CARRY FLAG**

**CCF**

**Instruction Word**

15	14	13	12	11	10	9	8	7	6	5	4	3	2	1	0	
1	0	0	1	0	1	0	0	0	0	0	0	0	0	1	0	
							Op Code					Condition Code			Flag Modification	

**Syntax**

CCF

**Operation**

Zero → Carry Bit

Flags: C: Set to 0.

**Description**

The Clear Carry Flag instruction resets the carry flag with a 0.

**Example**

CCF

Initialization: SR contains 3000H

Instruction: CCF

Result: SR contains 2000H  
C contains 0

This example uses one word of memory and executes in one machine cycle.



**CIEF CLEAR INTERRUPT ENABLE FLAG CIEF**

**Instruction Word**

15	14	13	12	11	10	9	8	7	6	5	4	3	2	1	0		
1	0	0	1	0	1	0	0	0	0	0	0	0	1	0	0		
							Op Code					Condition Code			Flag Modification		

**Syntax**

CIEF

**Operation**

Zero → IE bit

Flags: IE: Set to 0.

**Description**

The Clear Interrupt Enable Flag instruction sets the IE flag to 0.

**Example**

CIEF

Initialization: SR contains 3080H

Instruction: CIEF

Result: SR contains 3000H  
IE contains 0

This example uses one word of memory and executes in one machine cycle.



**COPF CLEAR      OVERFLOW PROTECTION FLAG      COPCLEAR**

**Instruction Word**

15	14	13	12	11	10	9	8	7	6	5	4	3	2	1	0				
1	0	0	1	0	1	0	0	0	0	0	0	1	0	0	0				
							Op Code					Condition Code				Flag Modification			

**Syntax**

COPF

**Operation**

Zero -> OP bit

Flags: P:      Set to 0.

The Clear Overflow Protection Flag instruction resets the OP flag to 0.

**Example**

COPF

Initialization:    SR contains 0100H

Instruction:      COPF

Result:            SR contains 0000H  
                      OP contains 0

This example uses one word of memory and executes in one machine cycle.





### Example

CP A, <regind>

Initialization: A contains 7A2500H  
P2:1 contains A4H  
RAM Bank1: A4H contains 5463H

Instruction: CP A, @P2:1

Result: A contains 7A2500H  
SR contains 1000H

This example uses one word of memory and executes in one machine cycle. The operand referenced by P2:1 is subtracted from the accumulator.  $7A2500H - 546300H = 25C200H$ . Because the comparison does not yield a 0, Bit 0 is not set. The content of the P2:1 register is appended with eight additional 0 bits. For consistent comparisons, the accumulator must contain zeros in the lower eight bits.

**Note:** The accumulator is unaffected by the operation.

### Example

CP A, <memind>

Initialization: A contains 7A2500H  
P2:1 contains A4H  
RAM Bank1: A4H contains 5463H  
ROM Address: 5463H contains 0C12H

Instruction: CP A, @@P2:1

Result: A contains 7A2500H  
P2:1 contains A4H  
RAM Bank1: A4H contains 5464H  
SR contains 1000H

This example uses one word of memory and executes in three machine cycles. The pointer P2:1 contains the RAM register location (A4H). The contents of this register have a ROM address. This address refers to the ROM data compared to the accumulator  $7A2500H - 0C1200H = 6E1300H$ . Because the comparison does not yield a 0, Bit 0 is not set. With memory indirect addressing, the ROM address is automatically incremented. Using CP A, @@P2:1 + performs the same operation and also increments P2:1 content to A5H.

### Example

CP A, <limm>



Initialization: A contains 7A2500H  
Instruction: CP A, #%7A25  
Result: A contains 7A2500H  
SR contains 3000H

This example uses two words of memory and executes in two machine cycles. The immediate operand is compared to the accumulator. Because they are equal, the Zero Flag is set.

### Example

```
CP A, <hwregs>
```

Initialization: A contains 7A2500H  
SR contains 0000H  
BUS contains 7A25H

Instruction: CP A, BUS

Result: A contains 7A2500H  
SR contains 3000H

This example uses one word of memory and executes in one machine cycle. The `<hwreg>` operand is subtracted from the accumulator. Because the two operands are equal, the zero-status bit is set High. `<hwregs>` can be compared from all hardware registers.

### Example

```
CP A, <direct>
```

Initialization: Accumulator contains 7A2500H  
RAM Bank0 F3H contains 5463H

Instruction: CP A, %F3

Result: A contains 7A2500H  
SR contains 1000H

This example uses one word of memory and executes in one machine cycle. Register F3H is compared to the accumulator.  $7A2500H - 546300H = 25C200H$ . An equivalent instruction is CP A, 243 (173H = 243 decimal).

### Example

```
CP A, <pregs>
```



Initialization: Accumulator contains 123400H  
P0:0 contains 56H

Instruction: CP A, P0:0

Result: Accumulator contains 123400H  
SR contains 1000H

This example uses one word of memory and executes in one machine cycle. The contents of the pointer register P0:0 are compared to the accumulator.  $123400H - 005600H = 11DE00H$ . The Pointer Register is connected to the lower 8 bits of the D-bus. The D-bus is connected to the upper 16 bits of the P-bus. This action changes the pointer register operand to 005600H before being compared to the accumulator.

### Example

CP A, <dregs>

Initialization: A contains 7A2500H  
D2:1 contains 5463H

Instruction: CP A, D2:1

Result A contains 7A2500H  
SR contains 1000H

This example uses one word of memory and executes in one machine cycle. The contents of the data pointer D2:1 are compared to the accumulator.  $7A2500H - 546300H = 25C200H$ .



DEC

DECREMENT

DEC

**Instruction Word**

15	14	13	12	11	10	9	8	7	6	5	4	3	2	1	0		
1	0	0	1	0	0	0	cc	cc	cc	cc	cc	0	1	0	1		
							Op Code					Condition Code				ACC Modification	

**Syntax**

```
DEC A
DEC <cc>, A
```

**Operation**

```
ACC - 1 -> ACC
```

- Flags: C: Set if carry is required for operation
- Z: Set if result is 0.
- N: Set if decrement results in a value less than 0.
- OV: Set if upper ( 7FFFFFFH) or lower ( 800000H) limits are exceeded.

**Description**

The accumulator decrements by 1. A condition code can be used to test for a specific condition before decrementing.

**Example**

```
DEC A
Initialization: A contains 7A2500H
Instruction: DEC A
Result: A contains 7A24FFH
```

This example uses one word of memory and executes in one machine cycle. The value in the accumulator decrements by 1.

**Example**

```
DEC <cc>, A
Initialization: A contains 7A2500H
```



Instruction:   DEC MI , A

Result:        A contains 7A2500H

This example uses one word of memory and executes in one machine cycle. Because the accumulator is not negative, the decrement instruction is not executed.





Instruction:    INC A

Result:        A contains 7A2501H

This example uses one word of memory and executes in one machine cycle. The value in the accumulator is incremented by 1.



**JP**

**JUMP**

**JP**

**Instruction Word**

15	14	13	12	11	10	9	8	7	6	5	4	3	2	1	0
1	0	0	0	1	1	0	cc	cc	cc	cc	cc	0	0	0	0
Op Code							Condition Code					Not Used			
15	14	13	12	11	10	9	8	7	6	5	4	3	2	1	0
a	a	a	a	a	a	a	a	a	a	a	a	a	a	a	a

16-Bit Address

**Syntax**

JP            <cc>,            <direct>

JP            <direct>

**Operation**

16-Bit address -> PC

Flags: None

**Description**

The instruction places the address of the referenced ROM location in the Program Counter (PC). Because the processor obtains its next instruction address from the PC, the processor jumps to the appropriate location. A condition code can be used to test for a specific condition for a JUMP to occur.

**Example**

JP <cc>, <direct>

Initialization: Routine 1 address contains 1455H

PC contains 1343H

User 0 input contains 1

Instruction: JP NUO, Routine 1

Result: PC contains 1343H

This example uses two words of memory and executes in two machine cycles. Because the User 0 input is set High, the condition code is not met. Therefore, the JUMP instruction does not execute. The User 0 input is used to control the flow of the software.



### Example

JP <direct>

Initialization: Routine 1 address contains 1455H  
PC contains 1343H

Instruction: JP Routine 1

Result: PC contains 1455H

This example uses two words of memory and executes in two machine cycles. The value in the program counter is replaced by the Routine 1 address (1455H).



LD

LOAD

LD

**Instruction Word**

15	14	13	12	11	10	9	8	7	6	5	4	3	2	1	0
0	0	0	0	0	0	1	b	0	0	1	1	s	s	s	s
Op Code							RAM Bank	Destination				Source			

**Syntax**

LD	A,	<pregs>
LD	<direct> ,	A
LD	<hwregs> ,	<dregs>
LD	A,	<dregs>
LD	<dregs> ,	<hwregs>
LD	<hwregs> ,	<limm>
LD	A,	<memind>
LD	<pregs> ,	<simm>
LD	<hwregs> ,	<accind>
LD	A,	<direct>
LD	<pregs> ,	<hwreg>
LD	<hwregs> ,	<memind>
LD	A,	<regind>
LD	<regind> ,	<limm>
LD	<hwregs> ,	<regind>
LD	A,	<hwregs>
LD	<hwregs> ,	<pregs>
LD	<hwregs> ,	<hwregs>

**Operation**

<source> -> <destination>

Flags: None



## Description

The LOAD command provides the ability to transfer data to several different locations in the processor including hardware registers, accumulator, stack, pointers and memory. All transfers across the various internal buses are transparent to the user.

### Notes:

1. A load using the X or Y register provides an automatic multiply operation. This means the operand can be obtained from any register location.
2. The P register is a read-only register, therefore the destination of the load cannot be the P register.
3. LD EXTN, EXTN is not allowed.
4. A LOAD instruction to the accumulator clears the lower 8 bits of the 24-bit accumulator.

### Example 1

```
LD A, <regind>
```

Initialization: A contains 7A2500H  
P2:1 contains A4H  
RAM Bank1: A4H contains 5463H

Instruction: LD A, @P2:1

Result: A contains 546300H

This example uses one word of memory and executes in one machine cycle. Indirect addressing through the pointer registers provides access to RAM data. The data in RAM Bank 1, register A4 is transferred to the accumulator. The contents of the P2:1 register are appended with eight additional 0 bits. This is added to verify a correct arithmetic comparison.

### Example 2

```
LD A, <memind>
```

Initialization: Accumulator contains 123400H  
P0:0 contains 21H  
RAM Bank0: 21H contains 247AH  
ROM Address: 247AHequals OC1 2H

Instruction: LD A, @@P0:0



Result: A contains 0C1 200H  
P0:0 contains 21H  
RAM Bank0: 21H contains 247BH

This example uses one word of memory and executes in three machine cycles. The pointer P0:0 contains the RAM register location (21H). The contents of this register have a ROM address. This address refers to the ROM data that loads to the accumulator. When memory indirect addressing is used, the ROM address is automatically incremented. Using LD A, @@P0:0+ has the same result, also incrementing the P0:0 content to 22H.

### Example 3

```
LD A, <limm>                               Cycles: 2  
                                              Words: 2
```

Initialization: Accumulator contains 123400H

Instruction: LD A, #2474

Result: A contains 247400H

This example uses two words of memory and executes in two machine cycles. The immediate operand 2474H loads to the accumulator.

### Example 4

```
LD A, <hwregs>
```

Initialization: Accumulator contains 123400H  
Register X contains 0C12H

Instruction: LD A, X

Result: A contains 0C1200H

This example uses one word of memory and executes in one machine cycle. The contents of Register X are loaded to the accumulator. All hardware registers can transfer from <hwregs>.

### Example 5

```
LD A, <direct>
```

Initialization: Accumulator contains 123400H  
RAM Bank0 F3H contains 0C12H

Instruction: LD A, %F3

Result: A contains 0C1200H

This example uses one word of memory and executes in one machine cycle. Register F3H is loaded to the accumulator. An equivalent instruction is LD A, 243 (F3H = 243 decimal).

### Example 6

LD A, <dregs>

Initialization: Accumulator contains 123400H  
D0:1 contains 8746H

Instruction: LD A, D0:1

Result: A contains 874600H  
D0:1 contains 8746H

This example uses one word of memory and executes in one machine cycle. The contents of the data pointer D0:1 load to the accumulator.

### Example 7

LD A, <pregs>

Initialization: Accumulator contains 123400H  
P0:0 contains 56H

Instruction: LD A, P0:0

Result: Accumulator contains 005600H

This example uses one word of memory and executes in one machine cycle. The contents of the pointer register P0:0 are loaded to the accumulator. The Pointer Register is connected to the lower 8 bits of the D-bus. The D-bus is connected to the upper 16 bits of the P-bus. This operation causes the pointer register operand to become 005600H before being loaded into the accumulator.

### Example 8

LD <direct>, A

Initialization: Accumulator contains 123400H  
RAM Bank0: 3CH contains 5678H

Instruction: LD %3C, A

Result: Accumulator contains 123400H  
RAM Bank0: 3CH contains 1234H

This example uses one word of memory and executes in one machine cycle. The current value in the accumulator is loaded to the register addressed by the instruction (3CH). An equivalent instruction is LD 60, A. (3CH = 60 decimal).



### Example 9

```
LD <pregs>, <simm>
```

Initialization: P2:0 contains 2FH  
RAM Bank0: 3FH contains 254645H

Instruction: LD P2:0, %#3F

Result: P2:0 contains 3FH  
RAM Bank0: 3FH contains 254645H

This example uses one word of memory and executes in one machine cycle. The immediate data (3FH) is loaded into the pointer register P2:0. This action provides a convenient method for initializing pointer registers.

### Example 10

```
LD <pregs>, <hwregs>
```

Initialization: P0:1 contains 2FH  
Y contains 2376H

Instruction: LD P0:1, Y

Result: P0:1 contains 76H  
Y contains 2376H

This example uses one word of memory and executes in one machine cycle. The lower 8-bits of the Y register are transferred to the pointer register P0:1. All hardware registers can transfer from <hwregs>.

### Example 11

```
LD <regind>, <limm>
```

Initialization: P0:1 contains 2FH  
RAM Bank0: 2FH contains 2376H

Instruction: LD @P0:1, %#35B8

Result: P0:1 contains 2FH  
RAM Bank1: 2FH contains 35B8H

This example uses two words of memory and executes in two machine cycles. The immediate operand 35B8H is transferred to the Register 2FH of RAM Bank1.

### Example 12

```
LD <hwregs>, <pregs>
```



Initialization: P2:0 contains 2FH  
X Register contains 8B87H

Instruction: LD X, P2:0

Result: P2:0 contains 2FH  
X Register contains 002FH

This example uses one word of memory and executes in one machine cycle. The contents of the P2:0 pointer (2FH) are loaded into the X register. Transfer to <hwreg> is possible to all hardware registers except the read-only P register.

### Example 13

LD <hwregs>, <dregs>

Initialization: D2:0 contains 3C87H  
Accumulator contains 8BB722H

Instruction: LD A, D2:0

Result: D2:0 contains 3C87H  
Accumulator contains 3C8700H

This example uses one word of memory and executes in one machine cycle. The contents of the D2:0 pointer (3C87H) are loaded into the accumulator. Transfer to <hwregs> is possible to all hardware registers except the read-only P register.

### Example 14

LD <hwregs>, <limm>

Initialization: Stack0 contains 8B2FH  
Stack1 contains 0000H

Instruction: LD Stack, #%35B8

Result: Stack0 contains 35B8H  
Stack1 contains 8B2FH

This example uses two words of memory and executes in two machine cycles. The immediate data is pushed onto the stack as previous stack data is pushed up the stack. Transfer to <hwregs> is possible to all hardware registers except the read-only P register.

### Example 15

LD <hwregs>, <accind>



Initialization: EXT7 Register contains 8B87H  
Accumulator contains 77B6H  
ROM 77B6H contains 387DH

Instruction: LD EXT7, @A

Result: EXT7 Register contains 387DH  
Accumulator contains 77B6H

This example uses one word of memory and executes in one machine cycle. The contents of the ROM Register 77B6H (387DH) are loaded into External Register 7. Transfer to `<hwregs>` is possible to all hardware registers except the read-only P register and the accumulator register.

### Example 16

LD `<hwregs>`, `<memind>`

Initialization: Y Register contains 1234H  
P0:0 contains 21H  
RAM Bank0: 21H contains 247AH  
ROM Address: 247AH contains 0C12H

Instruction: LID Y, @@P0:0

Result: Y Register contains 0C12H  
P0:0 contains 21H  
RAM Bank0: 21H contains 247BH

This example uses one word of memory and executes in three machine cycles. The pointer P0:0 contains the RAM register location (21H). The contents of this register have a ROM address that refers to the ROM data that loads to the Y register. Transfer to `<hwregs>` is possible to all hardware registers except the read-only P register. When memory indirect addressing is used the ROM address is automatically incremented. Using LD A, @@P0:0+ performs the same operation and also increments the P0:0 content to 22H.

### Example 17

LD `<hwregs>`, `<regind>`

Initialization: X Register contains 7A25H  
P21 contains A4H  
RAM Bank1: A4H contains 5463H

Instruction: LD X, @P2:1



Result: X Register contains 5463H

This example uses one word of memory and executes in one machine cycle. Indirect addressing through the pointer registers provides access to RAM data. The data in RAM bank 1, register A4 is transferred to the X register. Transfer to `<hwreg>` is possible to all hardware registers except the read-only P register.

### Example 18

```
LD <hwregs>, <hwregs>
```

Initialization: X Register contains 7A25H  
EXT5 Register contains 789AH

Instruction: LD X, EXT5

Result: X Register contains 789AH  
EXT5 Register contains 789AH

This example uses one word of memory and executes in one machine cycle. The EXT5 Register contents are transferred to the X register. Transfer to `<hwregs>` is possible to all hardware registers except the read-only P register.



**NEG**

**NEGATE**

**NEG**

**Instruction Word**

15	14	13	12	11	10	9	8	7	6	5	4	3	2	1	0				
1	0	0	1	0	0	0	cc	cc	cc	cc	cc	0	1	1	0				
							Op Code					Condition Code				ACC Modification			

**Syntax**

NEG A  
NEG <cc>, A

**Operation**

-ACC -> ACC

Flags: N Set if result is a negative number.

Two special cases are:

1. If ACC contains 000000 after execution, then N and OV are cleared, and Z and C are set
2. If ACC contains 800000 after execution, then N and OV are set; and Z and C are cleared.

The accumulator is replaced with a negative of the current value. To achieve this state, the two's complement is performed.

**Example 1**

NEG A

Initialization: A contains 003654H

Instruction: NEG A

Result: A contains FFC9ACH

This example uses one word of memory and executes in one machine cycle.



### Example 2

NEG <CC>, A

Initialization: A contains 000111H  
Carry bit contains 1

Instruction: NEG C, A

Result: A contains FFFEEFH

This example uses one word of memory and executes in one machine cycle.



**NOP**

**NO OPERATION**

**NOP**

**Instruction Word**

15	14	13	12	11	10	9	8	7	6	5	4	3	2	1	0
0	0	0	0	0	0	0	0	0	0	0	0	0	0	0	0

**Syntax**

NOP

**Operation**

PC+ 1 → PC

Flags:           None

**Description**

The NOP instruction causes the processor to continue operation for one cycle without affecting previous registers and I/O.



**OR BITWISE OR OR**

**Instruction Word**

15	14	13	12	11	10	9	8	7	6	5	4	3	2	1	0	
1	1	0	0	0	0	1	b	0	0	0	0	s	s	s	s	
							Op Code	RAM Bank	Destination				Source			

**Syntax**

- OR A, <regind>
- OR A, <memind>
- OR A, <limm>
- OR A, <hwregs>
- OR A, <direct>
- OR A, <pregs>
- OR A, <dregs>
- OR A, <simm>

**Operation**

ACC .OR. source -> ACC

- Flags: N      Set If result in accumulator is negative.
- Z      Set If result is 0.

**Description**

The accumulator performs an OR instruction on the contents of the specified register. The upper 16 bits of the accumulator are used. The result is placed in the accumulator. The OR instruction is frequently used to compare specific bits to assist in program control.

**Note:** The lower eight bits of the accumulator are unchanged after execution of the OR instruction.

**Example**

OR A, <regind>



Initialization: Accumulator contains 3264A0H  
P0:0 contains E2H  
RAM Bank0: E2H contains 1126H

Instruction: OR A, @P0:0

Result: A contains 336600H

This example uses one word of memory and executes in one machine cycle. Use an OR instruction to reference the operand P0:0 with the upper 16 bits of the accumulator. The result is stored in the accumulator. 3264A0H OR. 1126A0H = 3366A0H.

### Example 2

OR A, <memind>

Initialization: A contains 3264A0H  
P2:11 contains A4H  
RAM Bank 1: A4H contains 5463H  
ROM Address: 5463H contains 1126H

Instruction: OR A, @@P2:1

Result A contains 3366A0H  
P2:1 contains A4H  
RAM Bank0: A4H contains 5464H  
SR contains 0000H

This example uses one word of memory and executes in three machine cycles. The pointer P2:1 contains the RAM register location (A4H). The contents of this register have a ROM address. This address refers to the ROM data that is compared to the accumulator. 3264A0H.OR.112600H = 3366A0H. With memory indirect addressing, the ROM address is automatically incremented. Using ORA, @@P0:0+ performs the same operation and also increments the P0:0 content to A5H.

### Example 3

OR A, <limm>

Initialization: A contains 3264A0H

Instruction: OR A, #%1126

Result: A contains 3366A0H  
SR contains 0000H

This example uses two words of memory and executes in two machine cycles. The accumulator performs an OR instruction on the immediate data.



**POP** **POP VALUE FROM STACK** **POP**

**Instruction Word**

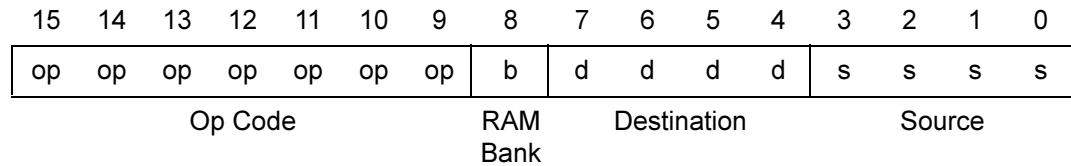

**Syntax**

- POP <pregs>
- POP <dregs>
- POP <regind>
- POP <hwregs>

**Operation**

- STACK 0 -> <destination>
- Stack n -> Stack N-1

Flags: None

**Description**

The current value of the stack is copied to the specified register. Because the stack is a last-in, first-out (LIFO) hard-wired architecture, the copy and shift of data remaining in the stack are all performed in a single cycle.

The POP instruction provides the ability to control information sent to the stack, making it possible to expand the stack using software.

**Example 1**

POP <pregs>

Initialization: Stack 1 contains 0426H  
Stack 0 contains 0C06H  
P0:0 contains 24H

Instruction: POP P0:0

Result Stack 0 contains 0426H  
P0:0 contains 06H



This example uses one word of memory and executes in one machine cycle. The destination of `Stack 0` (item on top of stack) is `P0:0`. The 8-LSBs of the data in `stack 0` are loaded into `P0:0`. At transfer, `Stack 1` is automatically moved to `Stack 0`.

### Example 2

`POP <dregs>`

Initialization: `Stack 1` contains `0426H`  
`Stack 0` contains `0C06H`  
`D0:0` contains `7676H`

Instruction: `POP D0:0`

Result: `Stack 0` contains `0426H`  
`D0:0` contains `0C06H`

This example uses one word of memory and executes in one machine cycle. The destination of the `Stack 0` (item on top of stack) is given by `D0:0`. When transferred, `Stack 1` is automatically moved to `Stack 0`.

### Example 3

`POP <regind>`

Initialization: `Stack 1` contains `0426H`  
`Stack 0` contains `0C06H`  
`P0:0` contains `24H`  
`RAM Bank0: 24H` contains `42A4H`

Instruction: `POP @P0:0`

Result `Stack 0` contains `0426H`  
`RAM Bank0: 24H` contains `0C06H`

This example uses one word of memory and executes in one machine cycle. The destination of the `Stack 0` (item on top of stack) is given by `P0:0`. `24H` is the register location in `RAM Bank0` to which the stack item is transferred. At transfer, `Stack 1` is automatically moved to `Stack 0`.

### Example 4

`POP <hwregs>`



Initialization: Stack 1 contains 0426H  
Stack 0 contains 0C06H  
X Register contains 089CH

Instruction: POP X

Result: Stack 0 contains 0426H  
X Register contains 0C06H

This example uses one word of memory and executes in one machine cycle. The destination of the Stack 0 (item on top of stack) is given by the X Register. At transfer, Stack 1 is automatically moved to Stack 0. Transfer to <hwregs> is possible to all hardware registers except the read-only P register.





Initialization: Stack 0 contains 0C06H  
P1:1 contains A4H  
Instruction: PUSH P1:1  
Result Stack 1 contains 0C06H  
Stack 0 contains 00A4H

This example uses one word of memory and executes in one machine cycle. The pointer P1:1 contains the 8-bit value A4H. The 16-bit value, 00A4H, is pushed onto the stack. At transfer, Stack 0 is automatically moved to Stack 1.

### Example 2

PUSH <dregs>

Initialization: Stack 1 contains 0426H  
Stack 0 contains 0C06H  
D1:1 contains 42A4H  
Instruction: PUSH D1:1  
Result Stack 1 contains 0C06H  
Stack 0 contains 42A4H

This example uses one word of memory and executes in one machine cycle. The pointer D1:1 is pushed onto the stack. At transfer, Stack 0 is automatically moved to Stack 1.

### Example 3

PUSH <memind>

Initialization: Stack 1 contains 0426H  
Stack 0 contains 0C06H  
RAM Bank0: 24H contains 42A4H  
P1:1 contains A4H  
RAM Bank1: A4H contains 5463H  
ROM Address 5463H contains 1126H  
Instruction: PUSH @@P1:1  
Result: Stack 1 contains 0C06H  
Stack 0 contains 1126H  
RAM Bank1: A4H contains 5464H

This example uses one word of memory and executes in three machine cycles. When memory indirect addressing is used, the ROM address is automatically incremented.



Using OR A, @@P0:0+ performs the same operation and also increments the P0:0 content to A5H.

#### Example 4

PUSH <accind>

Initialization: Stack 1 contains 0426H  
Stack 0 contains 0C06H  
Accumulator contains 42A4H  
ROM address 42A4H contains 4C45H

Instruction: PUSH @A

Result Stack 1 contains 0C06H  
Stack 0 contains 4C45H

This example uses one word of memory and executes in one machine cycle. Indirect addressing with the accumulator points to the ROM memory (42A4H) The data in this location is pushed onto the stack. At transfer, Stack 0 is automatically moved to Stack 1.

#### Example 5

PUSH <regind>

Initialization: Stack 1 contains 0426H  
Stack 0 contains 0C06H  
P1:1 contains A4H  
RAM Bank1: A4H contains 42A4H

Instruction: PUSH @P1:1

Result: Stack 1 contains 0C06H  
Stack 0 contains 42A4H  
RAM Bank1: A4H contains 42A4H

This example uses one word of memory and executes in one machine cycle. The pointer P1:1 contains the RAM register location (A4H). The data at this location is pushed onto the stack. At transfer, Stack 0 is automatically moved to Stack 1.

#### Example 6

PUSH <hwregs>

Initialization: Stack 1 contains 0426H  
Stack 0 contains 0C06H  
X Register contains 42A4H



Instruction:    PUSH X  
Result:        Stack 1 contains 0C06H  
               Stack 0 contains 42A4H

This example uses one word of memory and executes in one machine cycle. The data in the X register is pushed onto the stack. At transfer, Stack 0 is automatically moved to Stack 1. Transfer from <hwregs> is possible from all hardware registers.

### Example 7

PUSH <direct>

Initialization: Stack 1 contains 0426H  
                 Stack 0 contains 0C06H  
                 RAM Bank0: 24H contains 42A4H

Instruction:    PUSH %24  
Result:         Stack 1 contains 0C06H  
               Stack 0 contains 42A4H

This example uses one word of memory and executes in one machine cycle. The instruction (24H) provides the direct register address. The value contained in this register is pushed onto the stack (42A4H). At transfer, Stack 0 is automatically moved to Stack 1.

### Example 8

PUSH <limm>

Initialization: Stack 1 contains 0426H  
                 Stack 0 contains 0C06H

Instruction:    PUSH #5757  
Result:         Stack 1 contains 0C06H  
               Stack 0 contains 5757H

This example uses two words of memory and executes in two machine cycles. The immediate operand 5757H is pushed onto the stack. At transfer, Stack 0 is automatically moved to Stack 1.







### Example 2

RL <CC>, A

Initialization: A contains 226A84H  
Carry bit contains 0, Z=0

Instruction: RL Z, A

Result: A contains 226A84H

This example uses one word of memory and executes in one machine cycle. The condition code 0 is not set; therefore, the instruction is not executed.



RR ROTATE RIGHT RR

**Instruction Word**

15	14	13	12	11	10	9	8	7	6	5	4	3	2	1	0				
1	0	0	1	0	0	0	cc	cc	cc	cc	cc	0	0	0	0				
							Op Code					Condition Code				ACC Modification			

**Syntax**

```
RR A
RR <CC>, A
```

**Operation**

C =>23 ---- > 8 = => 7 - -> -- 0 -> discarded

- Flags: N Set if result of accumulator is negative.
- Z Set if result is 0.
- C Set if LSB is set before rotate.

**Description**

The upper 16 bits of ACC are rotated right through the carry bit. The MSB of the lower 8 bits also obtains the data shifted from the LSB of upper 16 bits. The lower 8 bits are shifted right with the LSB being discarded.

**Example 1**

```
RR A
Initialization: A contains 226A84H
                Carry bit contains 0
Instruction:    RR A
Result:        A contains 113542H
```

This example uses one word of memory and executes in one machine cycle. The upper 16 bits (226AH) are shifted right through the carry bit to produce 1135H. The lower 8 bits (84H) are shifted right to provide 42H.

**Example 2**

```
RR <CC>, A
```



Initialization: A contains 226A84H  
Carry bit contains 0, Z=0

Instruction: RR Z, A

Result: A contains 226A84H

This example uses one word of memory and executes in one machine cycle. The condition code 0 is not set; therefore, the instruction is not executed.



SCF

**SET CARRY FLAG**

SCF

**Instruction Word**

15	14	13	12	11	10	9	8	7	6	5	4	3	2	1	0
op	op	op	op	op	op	op	cc	cc	cc	cc	cc	fm	fm	fm	fm
Op Code							Condition Code					Flag Modification			

**Syntax**

SCF

**Operation**

1 → Carry Bit

Flags: C Set to 1.

**Description**

The Set Carry Flag instruction places a one in the carry bit (bit 12 of the Status Register).

**Example**

SCF

Initialization: SR contains 2000H

Instruction: SCF

Result: SR contains 3000H  
C contains 1

This example uses one word of memory and executes in one machine cycle.







Initialization: A contains 226A84H  
Carry bit contains 0

Instruction: SLL MI, A

Result: A contains 226A84H

This example uses one word of memory and executes in one machine cycle. The condition code N is not set, and the instruction is not executed.



**SOPF                      SET OVERFLOW PROTECTION FLAG                      SOPF**

**Instruction Word**

15	14	13	12	11	10	9	8	7	6	5	4	3	2	1	0				
1	0	0	1	0	1	0	0	0	0	0	0	1	0	0	1				
							Op Code					Condition Code				Flag Modification			

**Syntax**

SOPF

**Operation**

1 → OP bit

Flags: None

**Description**

The Set Overflow Protection Flag instruction places a one in bit 8 of the status register. If an ALU operation exceeds the limits of the processor, the overflow protection sets the overflow flag (OV) and holds the limit value in the accumulator.

**Example**

SOPF

Initialization: SR contains 0000H

Instruction: SOPF

Result: SR contains 0100H  
OP contains 1

This example uses one word of memory and executes in one machine cycle.





### Example 2

SRA            <cc>, A

Initialization: A contains 226A84H  
Carry bit contains 0, N=0

Instruction:    SRA A

Result:        A contains 113542H  
Carry bit contains 0

This example uses one word of memory and executes in one machine cycle. The condition code is set; therefore, the instruction is executed. The initialization of the accumulator sets the PL (NN) condition code.



**SUB**

**SUBTRACT**

**SUB**

**Instruction Word**

15	14	13	12	11	10	9	8	7	6	5	4	3	2	1	0	
0	0	1	0	0	0	1	b	0	0	0	0	s	s	s	s	
							Op Code	RAM Bank	Destination				Source			

**Syntax**

- SUB A, <regind>
- SUB A, <memind>
- SUB A, <limm>
- SUB A, <hwregs>
- SUB A, <direct>
- SUB A, <pregs>
- SUB A, <dregs>
- SUB A, <simm>

**Operation**

$$ACC - (Source) \rightarrow ACC$$

- Flags: C     Set if a carry from the most significant bit is performed.
- N     Set if the result in the accumulator is negative.
- Z     Set if the result is 0.
- OV    Set if the addition exceeds the upper (7FFFFFFH) or lower (800000H) limit of the accumulator.

**Description**

The addressed data memory operand is subtracted from the accumulator. The result is loaded into the accumulator.

The lower eight bits of the accumulator are cleared by the execution of the subtract instruction.

**Example 1**

- SUB A, <regind>



Initialization: Accumulator contains 874600H  
P0:1 contains 45H  
RAM Bank1: 45H contains 1234H

Instruction: SUB A, @P0:1

Result: A contains 751200H  
@P0:1 contains 1234H

This example uses one word of memory and executes in one machine cycle. The contents of the register pointed by P0:1 are subtracted from the accumulator. The difference is contained in the accumulator and the pointer is left unchanged. The register pointer contains 45H. Because the pointer references RAM Bank1, the absolute register is 145H (325). Therefore, the contents of register 145H are subtracted from the accumulator.  $874600H - 123400H = 751200H$ . The direct addressing equivalent is SUB A,%145 or SUB A,325.

### Example 2

SUB A, <memind>

Initialization: Accumulator contains 874600H  
P0:0 contains 21H  
RAM Bank0: 21H contains 247AH  
ROM Address: 247AH contains 1234H

Instruction: SUB A, @@P0:0+

Result: A contains 751200H  
P0:0 contains 22H  
RAM Bank0: 21 H contains 247BH

This example uses one word of memory and executes in three machine cycles. The pointer is used for memory indirect addressing. The pointer contains the address of the RAM (address 247AH). The RAM contains the address of the requested ROM data (data 247AH). This operand is subtracted from the accumulator.  $874600H - 123400H = 751200H$ .

### Example 3

SUB A, <limm>

Initialization: Accumulator contains 874600H

Instruction: SUB A, #%1234

Result: Accumulator contains 751200H



This example uses two words of memory and executes in two machine cycles. The immediate operand 8746H is subtracted from the accumulator.  $874600H - 123400H = 751200H$ .

#### Example 4

SUB A, <hwregs>

Initialization: Accumulator contains 874600H  
Register X contains 1234H

Instruction: SUB A, X

Result: A contains 751200H

This example uses one word of memory and executes in one machine cycle. The contents of Register X are subtracted from the accumulator.  $874600H - 123400H = 751200H$ . Transfer from <hwregs> is possible from all hardware registers.

#### Example 5

SUB A, <direct>

Initialization: Accumulator contains 874600H  
RAM Bank0: F3H contains 1234H

Instruction: SUB A, %F3

Result: A contains 751200H

This example uses one word of memory and executes in one machine cycle. The contents of register F3H are subtracted from the accumulator.  $874600H - 123400H = 751200H$ . An equivalent instruction is SUB A, 243 (F3H = 243 decimal).

#### Example 6

SUB A, <dregs>

Initialization: Accumulator contains 874600H  
D0: 1 contains 1234H

Instruction: SUB A, D0:1

Result: A contains 751200H  
D0:1 contains 1234H

This example uses one word of memory and executes in one machine cycle. The contents of the data pointer D0:1 are subtracted from the accumulator. The difference is contained in the accumulator and the pointer is left unchanged.



### Example 7

SUB A, <pregs>

Initialization: Accumulator contains 874600H  
P0:0 contains 56H

Instruction: SUB A, P0:0

Result: Accumulator contains 86F000H

This example uses one word of memory and executes in one machine cycle. The contents of pointer register P0:0 are subtracted from the accumulator.  $874600H - 005600H = 86F000H$ . The Pointer Register is connected to the lower 8 bits of the D-bus. The D-bus is connected to the upper 16 bits of the P-bus. This causes the pointer register operand to become 005600H before it is subtracted from the accumulator.



**XOR**

**BITWISE EXCLUSIVE OR**

**XOR**

**Instruction Word**

15	14	13	12	11	10	9	8	7	6	5	4	3	2	1	0	
1	1	1	0	0	0	1	b	0	0	0	0	s	s	s	s	
							Op Code	RAM Bank	Destination				Source			

**Syntax**

- XOR A, <regind>
- XOR A, <memind>
- XOR A, <limm>
- XOR A, <hwregs>
- XOR A, <direct>
- XOR A, <pregs>
- XOR A, <dregs>
- XOR A, <simm>

**Operation**

A.XOR.<operand> -> A

- Flags: C      Set if carry from the most significant bit is performed.
- N      Set if result in the accumulator is negative.
- Z      Set if result is 0.
- OV     Set if operation exceeds upper (7FFFFFFH) or lower (800000H) limit of accumulator.

**Description**

With the accumulator, perform an XOR instruction on the addressed data memory operand. The result loads into the accumulator.

The lower eight bits of the accumulator are cleared by the XOR instruction.

**Example 1**

XOR A, <regind>



Initialization: Accumulator contains 005600H  
P0:0 contains 00H  
RAM Bank0: 00H contains 1234H

Instruction: XOR A, @P0:0

Result: A contains 126200H

This example uses one word of memory and executes in one machine cycle. The pointer is used for memory indirect addressing. The pointer contains the address of the RAM (address 00H). Location 00H has operand 1234H. With the accumulator, 005600H, perform an XOR instruction to obtain the result 126200H.

### Example 2

XOR A, <memind>

Initialization: A contains 3264A0H  
P21 contains A4H  
RAM Bank1: A4H contains 5463H  
ROM Address: 5463H contains 1126H

Instruction: XOR A, @@P2:1

Result A contains 2342A0H  
P2:1 contains A41H  
RAM Bank1: A4H contains 5464H  
SR contains 0000H

This example uses one word of memory and executes in three machine cycles. The pointer P2:1 contains the RAM register location(A4H). The contents of this register have a ROM address. This address refers to the ROM data compared to the accumulator.

$3264A0H.XOR.112600H = 2342A0H$ . When indirect memory addressing is used, the ROM address is automatically incremented. Using XOR A, @@P2:1+ performs the same operation and also increments the P21 content to A5H.

### Example 3

XOR A, <limm>

Initialization: A contains 3264A0H

Instruction: XOR A, #%1126



Result:       A contains 2342A0H  
              SR contains 0000H

This example uses two words of memory and executes in two machine cycles. Perform an XOR instruction on the immediate data.

#### Example 4

XOR A, <hwreg>

Initialization: A contains 3264A0H  
                  SR contains 0000H  
                  BUS contains 1126H

Instruction:    XOR A, BUS

Result:        A contains 2342A0H  
              SR contains

This example uses one word of memory and executes in one machine cycle. With the accumulator, perform an XOR instruction on the <hwreg> operand.

#### Example 5

XOR A, <direct>

Initialization: Accumulator contains 3264A0H  
                  RAM Bank0: F3H contains 1126H

Instruction:    XOR A, %F3

Result:        A contains 2342A0H  
              SR contains 0000H

This example uses one word of memory and executes in one machine cycle. Register F3H is compared to the accumulator.  $3264A0H.XOR.112600H = 2342A0H$ . An equivalent instruction is XOR A, 243 (F3H = 243 decimal).



## 5 Electrical Characteristics

**Table 76 Absolute Maximum and Minimum Ratings**

Sym	Parameter	Min	Max	Units	Conditions
V <sub>CC</sub>	Power supply voltage	0	7	V	
V <sub>ID</sub>	Input voltage	-0.3	V <sub>CC</sub> +0.3	V	Digital inputs
V <sub>IA</sub>	Input voltage	-0.3	V <sub>CC</sub> +0.3	V	Analog inputs (A/D0–A/D4)
V <sub>O</sub>	Output voltage	-0.3	V <sub>CC</sub> +0.3	V	All push-pull digital outputs
V <sub>O</sub>	Output voltage	-0.3	V <sub>CC</sub> +0.3	V	PWM outputs
I <sub>OH</sub>	Output current high		-10	mA	one pin
I <sub>OH</sub>	Output current high		-100	mA	all pins
I <sub>OL</sub>	Output current low		20	mA	one pin
I <sub>OL</sub>	Output current low		200	mA	all pins
T <sub>A</sub>	Operating temperature	0	70	°C	
T <sub>S</sub>	Storage temperature	-65	150	°C	

**Table 77 DC Characteristics**

Symbol	Parameter	Min	Typ	Max	Units	Conditions
V <sub>CC</sub>	Power supply voltage	4.75	5.00	5.25	V	
V <sub>IL</sub>	Input voltage low	0	0.4	0.2 V <sub>CC</sub>	V	
V <sub>IH</sub>	Input voltage high	0.7V <sub>CC</sub>	3.6	V <sub>CC</sub>	V	
V <sub>IHR</sub>	Input voltage High on Reset pin	0.75 V <sub>CC</sub>	4.2	V <sub>CC</sub>	V	
V <sub>PU</sub>	Maximum pull-up voltage			V <sub>CC</sub>	V	For PWM
V <sub>OL</sub>	Output voltage low		0.16	0.4	V	@ I <sub>OL</sub> = 1 mA
V <sub>OH</sub>	Output voltage high	V <sub>CC</sub> -0.4	4.75		V	@ I <sub>OH</sub> = -0.75 mA
I <sub>OL</sub>	Output current low	7.2	12		mA	@ V <sub>OL</sub> = 0.4v
I <sub>OL1</sub>	Output current low	12	20		mA	@ V <sub>OL</sub> = 0.8v
I <sub>OH</sub>	Output current high	4.0	7.0		mA	@ V <sub>OH</sub> = V <sub>CC</sub> -0.4



Table 77 DC Characteristics (Continued)

Symbol	Parameter	Min	Typ	Max	Units	Conditions
I <sub>OH1</sub>	Output current high	16	20		mA	@ V <sub>OH</sub> = 2.4v
I <sub>OL</sub>	Output current Low	0.35	0.65		mA	@ V <sub>OL</sub> = 0.4v
I <sub>OL1</sub>	Output current Low	0.65	1.1		mA	@ V <sub>OL</sub> = 0.8v
I <sub>OH</sub>	Output current High	0.35	0.65		mA	@ V <sub>OH</sub> = V <sub>CC</sub> -0.4
I <sub>OH1</sub>	Output current High)	1.1	2.5		mA	@ V <sub>OH</sub> = 2.4V
V <sub>XL</sub>	Input voltage XTAL1 low			0.3 V <sub>CC</sub>	V	External clock generator driven
V <sub>XH</sub>	Input voltage XTAL1 high	0.6 V <sub>CC</sub>			V	
I <sub>IR</sub>	Reset input current	40	90	150	μA	V <sub>RL</sub> = 0V
I <sub>IL</sub>	Input leakage	-3.0	0.01	3.0	μA	@ 0V and V <sub>CC</sub>
I <sub>CC</sub>	Supply current		60	100	mA	All ports are inputs, RGB is in digital mode
I <sub>CC</sub>	Supply current		30	50	mA	All ports are inputs, RGB is in analog mode
I <sub>CC1</sub>	Supply current		5	10	mA	Sleep mode @ 32.768 kHz
I <sub>CC2</sub>	Supply current		50	100	μA	Stop mode all PWM outputs are @ V <sub>IN</sub> = 0V

## 5.1 DC Peripherals

Table 78 V1, V2, and V3 (R,G,B) Analog Output

	Output Voltage (30KΩ Load)			Settling Time
	@ V <sub>CC</sub> = 4.75V	@ V <sub>CC</sub> = 5.00V	@ V <sub>CC</sub> = 5.25V	
				70% of DC Level, 10pF Load
data = 00	0.00V-0.65V	0.00V-0.70V	0.00V-0.75V	<50ns
data = 01	1.70V-0.20V	1.80V-0.20V	1.90V-0.20V	
data = 10	2.80V-0.25V	2.90V-0.25V	3.00V-0.25V	
data = 11	3.90V-0.30V	4.00V-0.30V	4.10V-0.30V	



Table 79 ADC0/Small Range\*

Sym	Parameter	Min	Typ	Max	Units
$U_{R-}$	Clamping voltage at ADC0	1.0	1.5	2.0	V
ADC <sub>0</sub>	Input voltage for level 0	$U_{R-} - (U_{R+} + U_{R-})/15$	$U_{R-}$	$U_{R-} + (U_{R+} - U_{R-})/15$	V
ADC <sub>1</sub>	Input voltage for level 1	$U_{R-}$	$U_{R-} + (U_{R+} - U_{R-})/15$	$U_{R-} + 2(U_{R+} - U_{R-})/15$	V
ADC <sub>2</sub>	Input voltage for level 2	$U_{R-} + (U_{R+} - U_{R-})/15$	$U_{R-} + 2(U_{R+} - U_{R-})/15$	$U_{R-} + 3(U_{R+} - U_{R-})/15$	V
ADC <sub>3</sub>	Input voltage for level 3	$U_{R-} + 2(U_{R+} - U_{R-})/15$	$U_{R-} + 3(U_{R+} - U_{R-})/15$	$U_{R-} + 4(U_{R+} - U_{R-})/15$	V
ADC <sub>4</sub>	Input voltage for level 4	$U_{R-} + 3(U_{R+} - U_{R-})/15$	$U_{R-} + 4(U_{R+} - U_{R-})/15$	$U_{R-} + 5(U_{R+} - U_{R-})/15$	V
ADC <sub>5</sub>	Input voltage for level 5	$U_{R-} + 4(U_{R+} - U_{R-})/15$	$U_{R-} + 5(U_{R+} - U_{R-})/15$	$U_{R-} + 6(U_{R+} - U_{R-})/15$	V
ADC <sub>6</sub>	Input voltage for level 6	$U_{R-} + 5(U_{R+} - U_{R-})/15$	$U_{R-} + 6(U_{R+} - U_{R-})/15$	$U_{R-} + 7(U_{R+} - U_{R-})/15$	V
ADC <sub>7</sub>	Input voltage for level 7	$U_{R-} + 6(U_{R+} - U_{R-})/15$	$U_{R-} + 7(U_{R+} - U_{R-})/15$	$U_{R-} + 8(U_{R+} - U_{R-})/15$	V
ADC <sub>8</sub>	Input voltage for level 8	$U_{R-} + 7(U_{R+} - U_{R-})/15$	$U_{R-} + 8(U_{R+} - U_{R-})/15$	$U_{R-} + 9(U_{R+} - U_{R-})/15$	V
ADC <sub>9</sub>	Input voltage for level 9	$U_{R-} + 8(U_{R+} - U_{R-})/15$	$U_{R-} + 9(U_{R+} - U_{R-})/15$	$U_{R-} + 10(U_{R+} - U_{R-})/15$	V
ADC <sub>A</sub>	Input voltage for level A	$U_{R-} + 9(U_{R+} - U_{R-})/15$	$U_{R-} + 10(U_{R+} - U_{R-})/15$	$U_{R-} + 11(U_{R+} - U_{R-})/15$	V
ADC <sub>B</sub>	Input voltage for level B	$U_{R-} + 10(U_{R+} - U_{R-})/15$	$U_{R-} + 11(U_{R+} - U_{R-})/15$	$U_{R-} + 12(U_{R+} - U_{R-})/15$	V
ADC <sub>C</sub>	Input voltage for level C	$U_{R-} + 11(U_{R+} - U_{R-})/15$	$U_{R-} + 12(U_{R+} - U_{R-})/15$	$U_{R-} + 13(U_{R+} - U_{R-})/15$	V
ADC <sub>D</sub>	Input voltage for level D	$U_{R-} + 12(U_{R+} - U_{R-})/15$	$U_{R-} + 13(U_{R+} - U_{R-})/15$	$U_{R-} + 14(U_{R+} - U_{R-})/15$	V
ADC <sub>E</sub>	Input voltage for level E	$U_{R-} + 13(U_{R+} - U_{R-})/15$	$U_{R-} + 14(U_{R+} - U_{R-})/15$	$U_{R-} + 15(U_{R+} - U_{R-})/15$	V
ADC <sub>F</sub>	Input voltage for level F	$U_{R-} + 14(U_{R+} - U_{R-})/15$	$U_{R+}$	$U_{R-} + 16(U_{R+} - U_{R-})/15$	V
$R_{IN}$	Input impedance	1.0			MΩ

Note: 1.5–2.0 V; TA = 0 °C to 70 °C; VCC = 4.75 V to 5.25 V

\*The Input voltage level indicated in the table is a switch point from one ADC level to another. To be in the middle of the level half, LSB  $((U_{R+} - U_{R-})/(15 * 2))$  must be added. The Input voltage must be prorated accordingly if V<sub>CC</sub> is changed.

**Table 80 ADC1-ADC4/Full Range**

Data from ADC	Input voltage (volts)	Data from ADC	Input voltage (volts)	Data from ADC	Input voltage (volts)	Data from ADC	Input voltage (volts)
0000	0.000 ± 0.15	0100	1.250 ± 0.15	1000	2.500 ± 0.15	1100	3.750 ± 0.15
0001	0.312 ± 0.15	0101	1.563 ± 0.15	1001	2.813 ± 0.15	1101	4.063 ± 0.15
0010	0.625 ± 0.15	0110	1.875 ± 0.15	1010	3.125 ± 0.15	1110	4.375 ± 0.15
0011	0.934 ± 0.15	0111	2.188 ± 0.15	1011	3.438 ± 0.15	1111	4.688 ± 0.15
Input impedance	> 1.0 MΩ						
Note: 0–5.0 V, V <sub>CC</sub> = 5.0 V, Temp=0–70 °C							

## 5.2 AC Characteristics

Table 81 lists the AC characteristics.

**Table 81 AC Characteristics**

Sym	Parameter	Min	Typ	Max	Units
T <sub>PC</sub>	Input clock period	16	32	100	μS
T <sub>RC</sub> , T <sub>FC</sub>	Clock input Rise and Fall		12		ns
TD <sub>POR</sub>	Power on reset delay	0.8	1.2		S
TW <sub>RES</sub>	Power on reset minimum width			5 TPC	μS
TD <sub>HS</sub>	HSYNC incoming signal width	1	10	15	μS
TD <sub>VS</sub>	VSYNC incoming signal width	1	200	10000	μS
TD <sub>ES</sub>	Time delay between leading edge of VSYNC and HSYNC in EVEN field	-12	0	+12	μS
TD <sub>OS</sub>	Time delay between leading edge of VSYNC and HSYNC in ODD field	20	32	44	μS
TW <sub>HVS</sub>	HSYNC/VSYNC edge width		0.5	2.0	μS

Note: T<sub>A</sub> = 0 °C to 70 °C; V<sub>CC</sub> = 4.75 V to 5.25 V; F<sub>OSC</sub> = 32,768 Hz)

All timing of the I<sup>2</sup>C bus interface are defined by related specifications of the I<sup>2</sup>C bus interface.

### 5.3 ANALOG RGB

The RGB outputs in analog mode are controlled current sources with an internal load. These outputs display gamma-corrected,  $V_{CC}$  prorated characteristics. See Table 82, Table 83, and Figure 28.

**Table 82 RGB Voltage Specification**

Parameter	Min	Typical	Max	Units
Supply voltage	4.5	5.0	5.5	V
Full scale voltage	1.8V	2.00V (0.40 * $V_{CC}$ )	2.2V	V
2/3 scale voltage	1.5V	1.65V (0.33 * $V_{CC}$ )	1.815V	V
1/3 scale voltage	1.125V	1.25V (0.25 * $V_{CC}$ )	1.375V	V
Zero scale voltage	—	0.00V (0.00 * $V_{CC}$ )	+0.1 V	V

Note: \*Measured with 3.9 k $\Omega$  load.

**Table 83 RGB Time Specification**

Parameter	Min	Typical	Max	Units
Output rise time		50	65	ns
Output fall time		50	65	ns

Note: \*Measured with 3.9 k $\Omega$  resistor in parallel with 30 pF capacitor load.

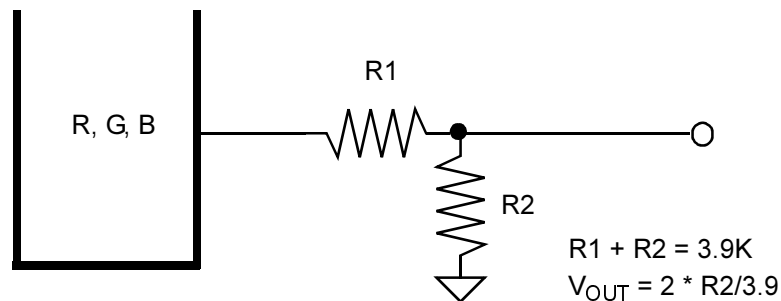

**Figure 28 Recommended Application Schematics**



## **6 System Design Considerations**

The Z90356 provides the ability to

- decode closed-caption transmissions
- display characters on the screen
- manipulate analog and digital control circuits
- monitor keypad and infrared signals directly
- generate OSD if the Z90356 receives vertical and horizontal synchronization signals

In a typical system, normal transmission is received and demodulated. The signals received from the color decoder and deflection unit control the CRT display. To display characters generated by the Z90356 requires a video multiplexor which enables the CRT display's RGB signals and synchronization to be controlled by the video outputs from the processor. When the controller has to display a character on the screen, the multiplexor is switched, and the processor's video signals appear on the display.

The band-limited, A/C-coupled composite video signal is clamped internally to the negative reference voltage (REF-) during the back porch interval. It is then passed to the analog-to-digital converter through a 6:1 multiplexor. The digital signal is then decoded to extract the closed-caption text embedded in the video signal. The characters received are generated as video signals and are then passed to the display.

When a detectable composite video signal is received, the SYNC separator extracts the horizontal and vertical synchronization signals and passes them to the deflection module of the television. The FLYBACK signals from the deflection coils are fed back to the Z90356. The controller uses these signals to align its video signals with those of the normal display. If the composite video signal is not present, video synchronization is provided by the controller. In this case, the SYNC signal pins are set to be outputs. The pins then feed to the deflection unit which controls the display. The SYNC generators can be configured to provide either HSYNC and VSYNC, or H-FLYBACK and V-FLYBACK.

Analog functions such as volume and color controls can be controlled by pulse width modulated outputs from the Z90356. Additional digital controls like channel fine tuning are controlled via the serial I<sup>2</sup>C bus.

An infrared remote control receiver can be directly decoded through the capture register, and keypad input can be scanned by directly controlling I/O pins as keyscan ports.

The processor clock is available by referencing an internal phase locked loop to an external 32.768 KHz crystal oscillator. The oscillator minimizes EMI emissions from the clock circuitry. The internal system clock frequency can be selected as 12.058 MHz in normal operation or 32.768 KHz in low power consumption SLEEP mode (usually used if

there is a general system power failure). The Z90356's STOP mode suspends processor clocking for a power-down.

Program, display, and character graphics memory are on the chip, eliminating the requirement for external memory components. Characters can be displayed as two or three times normal size. Smoothing and fringing circuits enhance display appearance.

Figure 29 diagrams a typical application of the Z90356 Television Controller as an embedded controller in a television.

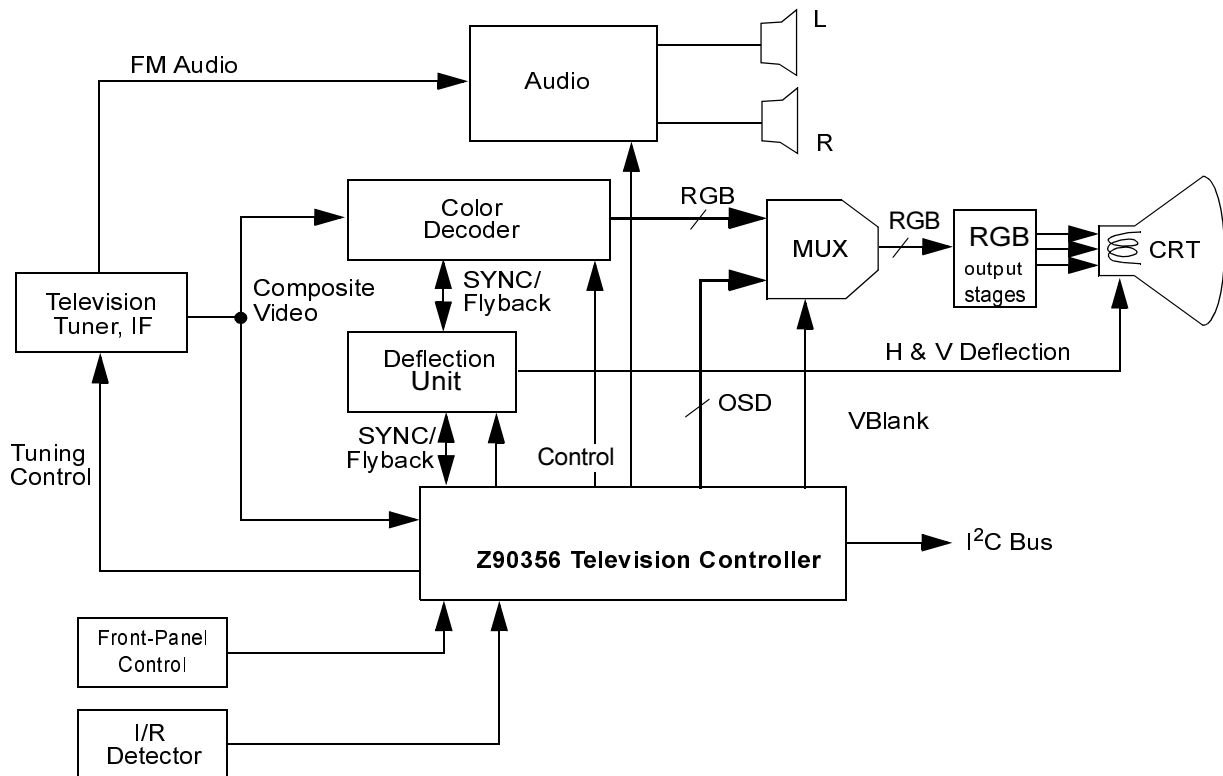

**Figure 29 System Block Diagram**

## 7 Packaging

Figure 30 and Table 84 indicate the controlling dimensions.

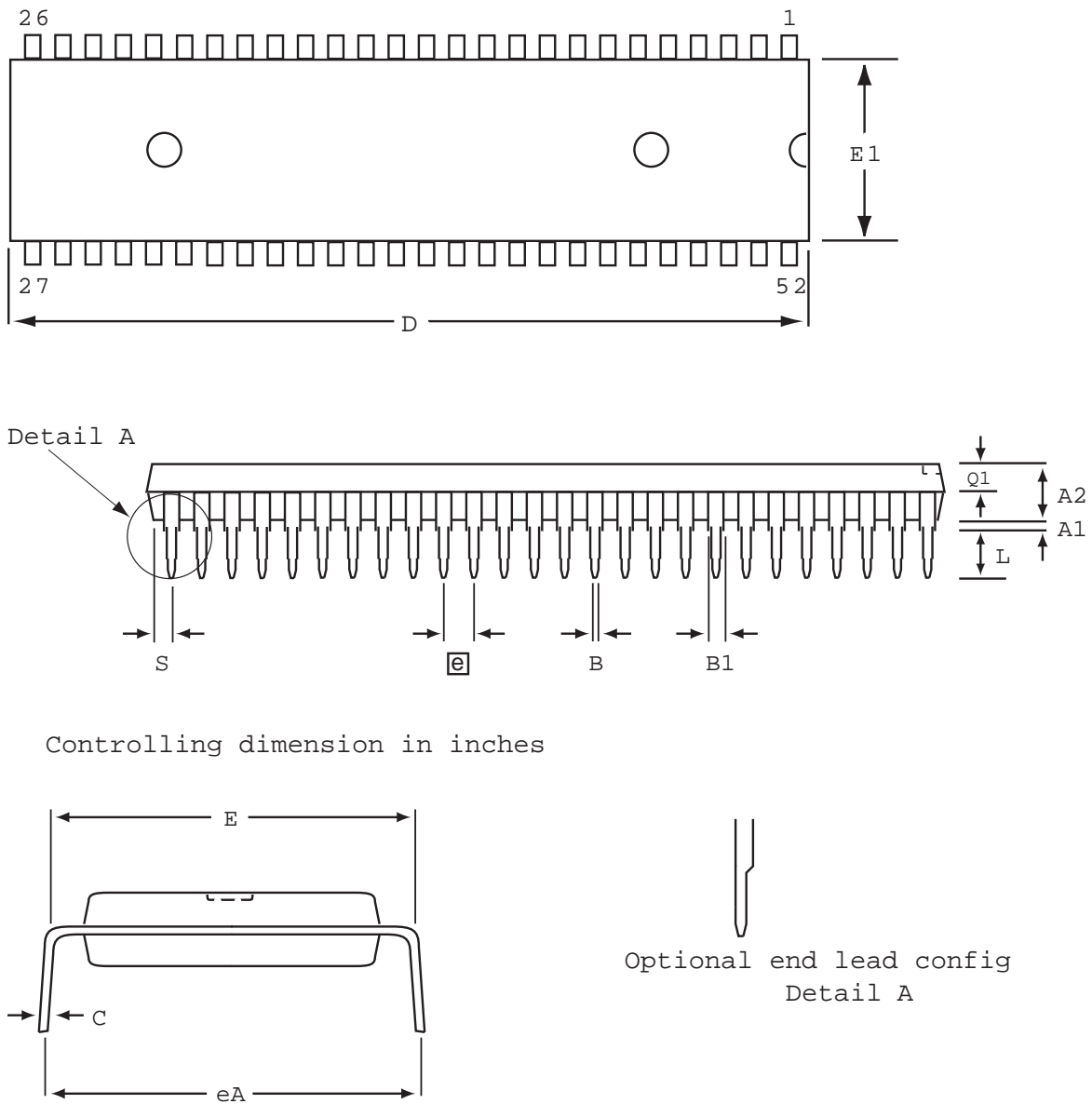

Figure 30 52-Pin SDIP Package Dimensions



Table 84 Controlling Dimensions

Symbol	Millimeter		Inch	
	Min	Max	Min	Max
A1	0.51	—	0.020	—
A2	3.25	3.94	0.128	0.155
B	0.38	0.53	0.015	0.021
B1	0.89	1.14	0.035	0.045
C	0.23	0.38	0.009	0.015
D	—	47.50	—	1.870
E	15.24	15.75	0.600	0.620
E1	13.72	14.10	0.540	0.555
e	1.778 TYP		0.070 TYP	
eA	15.49	16.76	0.610	0.660
L	3.05	3.68	0.120	0.145
Q1	1.52	1.91	0.060	0.075
S	0.64	1.78	0.025	0.070



## **Customer Feedback Form**

### **Z90356 Product Specification**

If there are any problems while operating this product, or any inaccuracies in the specification, please copy and complete this form, then mail or fax it to ZiLOG. Suggestions welcome!

### **Customer Information**

Name	Country
Company	Phone
Address	Fax
City/State/Zip	E-Mail

### **Product Information**

Serial # or Board Fab #/Rev. #
Software Version
Document Number
Host Computer Description/Type

### **Return Information**

ZiLOG  
System Test/Customer Support  
910 E. Hamilton Avenue, Suite 110, MS 4-3  
Campbell, CA 95008  
Fax: (408) 558-8536      Email: tools@zilog.com

### **Problem Description or Suggestion**

Provide a complete description of the problem or suggestion. For specific problems, include all steps leading up to the occurrence of the problem. Attach additional pages as necessary.

---

---

---

---