

FEATURES

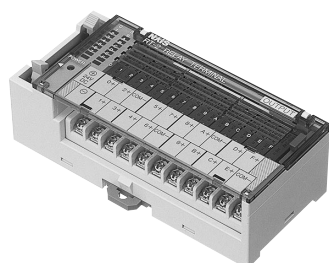

Pressure connector connect type

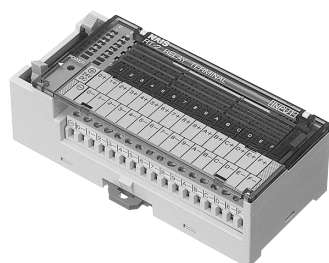

Wire-direct connect type

- Compact, space-saving design:**
 The Relay Terminal with 16 I/O channels measures only (W)116 × (D)52 × (H)37 mm (W)4.57×(D)2.047×(H)1.457 inch. The compact design contributes to equipment downsizing.
- Incorporates PA Relays with high-sensitivity twin contacts and Au-cladding:**
 The Relay Terminal incorporates 5 mm .197 inch wide PA relays. The PA relay features high sensitivity (12 V type = 120 mW, 24 V type = 180 mW) and twin contacts with Au-cladding, which combine to ensure high reliability under low-level loads.
- Available in input and output devices**
- Available in Pressure connector connect type and wire-direct connect type:**
 Pressure connector connect type has a single common for four I/O channels. The Wire-direct connect type has a single common for each I/O channel.
- Incorporates a surge absorber:**
 The RT-2 Series incorporates a surge absorber to protect the programmable controller internal electronics from inductor turn-off surges.

- Equipped with LED indicator lights:**
 LED indicators allow the user to identify the relay status at a glance.
- Comes with AXM connector (long lever version):**
 The RT-2 Series comes with the AXM connector (complying with the MIL standard) for single connections. Cable designed for use with AXM connectors are also available.
- Ease of mounting on DIN rails:**
 The DIN rail mounting hook of relay terminal is provided with a release/retention mechanism to ease mounting and removal.
- Available with a wide variety of cables:**
 A wide variety of assembled cables offers compatibility with our programmable controllers, and wire-pressed terminal cables provide compatibility with other controllers.

ORDERING INFORMATION

Ex. RT2S - M - C - ID - 16 - 12V

Installation type	Termination type	I/O type	No. of I/O channels	Rated voltage
Blank: DIN rail mounting type M: Direct mounting type	Blank: Pressure connector connect type C: Wire-direct connect type	ID: Input device (DC) OD: Output device (DC)	16: 16 channels	12 V: 12 V DC 24 V: 24 V DC

Note: Please consult us regarding minus common types for input.

RT-2

TYPES

1. DIN Rail Mounting Type

1) Pressure connector connect type

I/O type	Rated voltage	Part No.	Packing quantity	
			Inner carton	Outer carton
Input device	12 V DC	RT2S-ID16-12V	1 pc.	10 pcs.
	24 V DC	RT2S-ID16-24V		
Output device	12 V DC	RT2S-OD16-12V		
	24 V DC	RT2S-OD16-24V		

2) Wire-direct connect type

I/O type	Rated voltage	Part No.	Packing quantity	
			Inner carton	Outer carton
Input device	12 V DC	RT2S-C-ID16-12V	1 pc.	10 pcs.
	24 V DC	RT2S-C-ID16-24V		
Output device	12 V DC	RT2S-C-OD16-12V		
	24 V DC	RT2S-C-OD16-24V		

2. Direct Mounting Type

1) Pressure connector connect type

I/O type	Rated voltage	Part No.	Packing quantity	
			Inner carton	Outer carton
Input device	12 V DC	RT2S-M-ID16-12V	1 pc.	10 pcs.
	24 V DC	RT2S-M-ID16-24V		
Output device	12 V DC	RT2S-M-OD16-12V		
	24 V DC	RT2S-M-OD16-24V		

2) Wire-direct connect type

I/O type	Rated voltage	Part No.	Packing quantity	
			Inner carton	Outer carton
Input device	12 V DC	RT2S-MC-ID16-12V	1 pc.	10 pcs.
	24 V DC	RT2S-MC-ID16-24V		
Output device	12 V DC	RT2S-MC-OD16-12V		
	24 V DC	RT2S-MC-OD16-24V		

3. Interface Relay

Type	Rated voltage	Part No.	Packing quantity	
			Inner carton	Outer carton
PA relay	12 V DC	PA1a-12V	25 pcs.	1,000 pcs.
	24 V DC	PA1a-24V		

RATINGS

1. Relay coil specifications (per PA relay)

Rated coil voltage	Pick-up voltage (at 20°C 68°F)	Drop-out voltage (at 20°C 68°F)	Rated exciting current (±10%)	Coil resistance (±10%) (at 20°C 68°F)	Rated power consumption	Max. continuous voltage (at 55°C 131°F) V DC
12 V DC	less than 70% of nominal voltage	more than 5% of nominal voltage	10 mA	1,200 Ω	120 mW	14.4
24 V DC			7.5 mA	3,200 Ω	180 mW	28.8

Note: The LED draws a drive current of approximately 3 mA per channel. When calculating the supply capacity required, include the total current consumed by the LEDs.

2. Contacts (per PA relay)

Specification	Item	Performance
Contact rating	Rated control capacity (resistive load)	2 A 250 V AC, 2 A 30 V DC
	Maximum allowable contact power (resistive load)	500 VA (AC), 60 W (DC)
	Maximum allowable contact voltage	250 V AC, 30 V DC
	Maximum allowable contact current	2 A
	Minimum load (ref. value)	100 mV 100 μA
Expected life (minimum operations)	Electrical (resistive load)	10 ⁵ : 2 A 250V AC 10 ⁵ : 2 A 30V DC 3 × 10 ⁵ : 1 A 250V AC 3 × 10 ⁵ : 1 A 30V DC
	Mechanical (at 180 cpm)	2 × 10 ⁷

PERFORMANCE

Item		Input	Output
Initial Insulation resistance (Min.)	Between connector terminals	100 MΩ (excluding battery at 500 V DC megger)	100 MΩ (excluding battery at 500 V DC megger)
	Between unlike poles on the terminals	100 MΩ (at 500 V DC megger)	100 MΩ (at 500 V DC megger)
	Between like poles on the terminals (for output)	—	100 MΩ (at 500 V DC megger)
Initial breakdown voltage (Min.)	Between connector terminals	2,000 Vrms for 1 min. (excluding battery)	2,000 Vrms for 1 min. (excluding battery)
	Between unlike poles on the terminals	1,500 Vrms for 1 min.	1,500 Vrms for 1 min.
	Between like poles on the terminals (for output)	—	1,000 Vrms for 1 min.
Vibration resistance	Destructive	10 to 55 Hz at double amplitude 1 mm .039 inch	10 to 55 Hz at double amplitude 1 mm .039 inch
	Functional	10 to 55 Hz at double amplitude 1 mm .039 inch	10 to 55 Hz at double amplitude 1 mm .039 inch
Shock resistance	Destructive	Min. 196 m/s ² {20G}	Min. 196 m/s ² {20G}
	Functional	Min. 98 m/s ² {10G}	Min. 98 m/s ² {10G}
Superimposed power noise		Min. 1,000 V*	Min. 1,000 V*
Superimposed I/O noise		Min. 1,000 V*	Min. 1,500 V*
Ambient temperature		0°C to +55°C +32°F to +131°F	0°C to +55°C +32°F to +131°F
Ambient humidity		35% to 85% R.H. (Not condensing)	35% to 85% R.H. (Not condensing)
Storage temperature		-30°C to +80°C -22°F to +176°F (Not freezing and condensing)	-30°C to +80°C -22°F to +176°F (Not freezing and condensing)
Terminal screw fasten torque		0.3 to 0.5 N·m (3 to 5 kgf·cm) for pressure connector connect type; 0.2 to 0.4 N·m (2 to 4 kgf·cm) for wire-direct connect type	
Coil surge absorber		Diode (1 A, 400 V)	Diode (1 A, 400 V)
Cross connection protecting diode		1A, inverse voltage 40 V	1.5 A, inverse voltage 40 V
Weight		Approx. 200 g 7.1 oz	Approx. 200 g 7.1 oz

*According to in-house measurement.

- Notes: 1. The value of breakdown voltage and insulation resistance is the initial one.
 2. Condensing occurs when the unit relay is exposed to sudden temperature change in a high temperature and high humidity atmosphere. This may cause some troubles like insulation failure of the socket or the print circuit board. Take care under this condition
 3. Below 0°C 32°F, condensing water can freeze and cause socket contact failures and other problems. Take care under this condition.

TERMINAL BLOCK

1. Pressure connector connect type

- Applicable electrical wire
0.25 to 1.65 mm² .01 to .065 inch
- Applicable wire-pressed terminals

mm inch

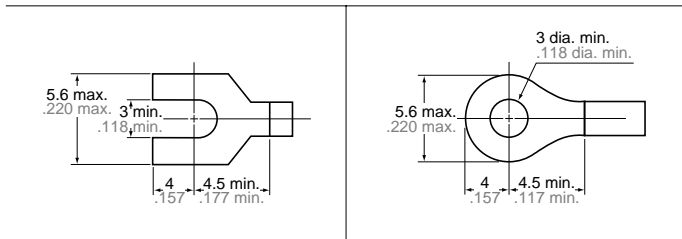

2. Wire-direct connect type

Strip the wire ends as follows:

Stripping length	Recommended wire
8 to 10 mm .315 to .394 inch	0.128 to 1.318 mm .005 to 0.52 inch 0.4 to 1.3 mm dia. .016 to .051 inch

DATA

1. Maximum value for switching capacity per PA relay (output)

2. Life curve per PA relay (output)

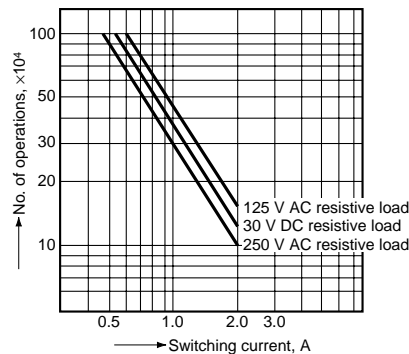
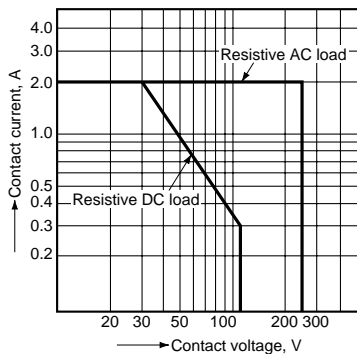

RT-2

DIMENSIONS

mm inch

Dimensions are common to both input and output module.

1. DIN rail mounting

Pressure connector connect type

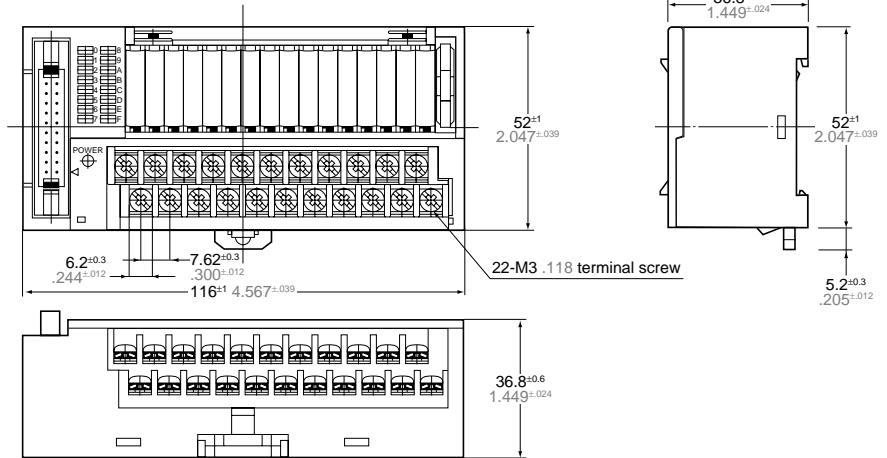
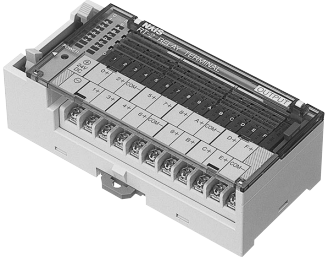

Wire-direct connect type

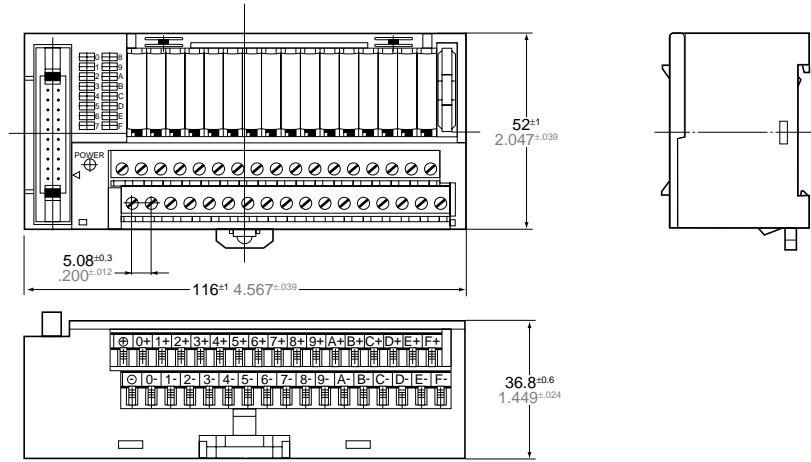
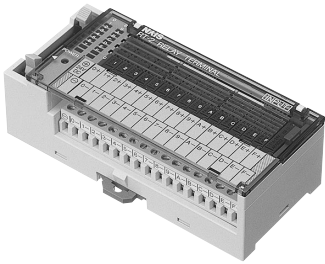

2. Direct mounting

Pressure connector connect type

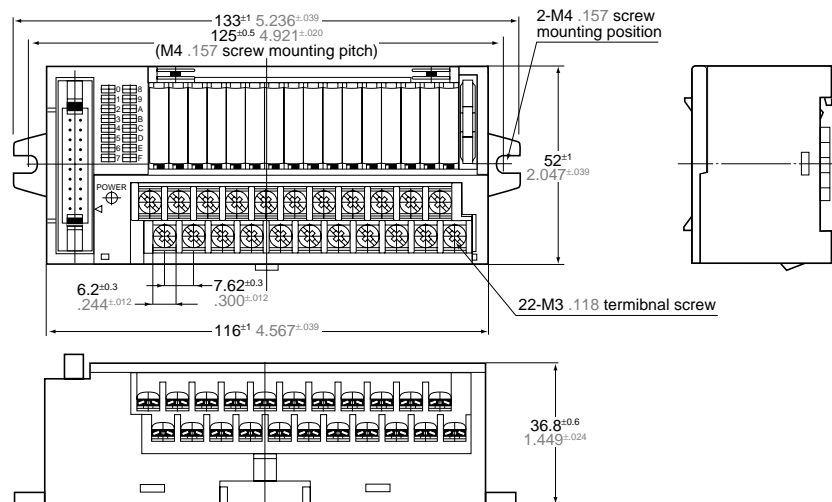
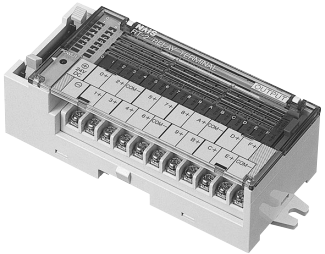

Wire-direct connect type

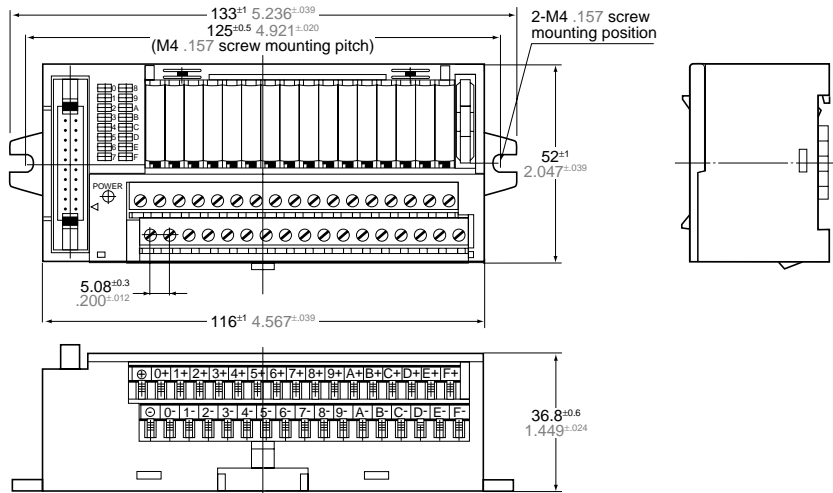
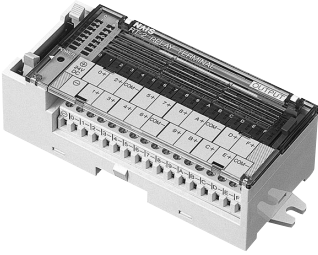

SCHEMATIC (common to both DIN rail mounting and direct mounting)

1. Pressure connector connect type (4 commons)

Input module

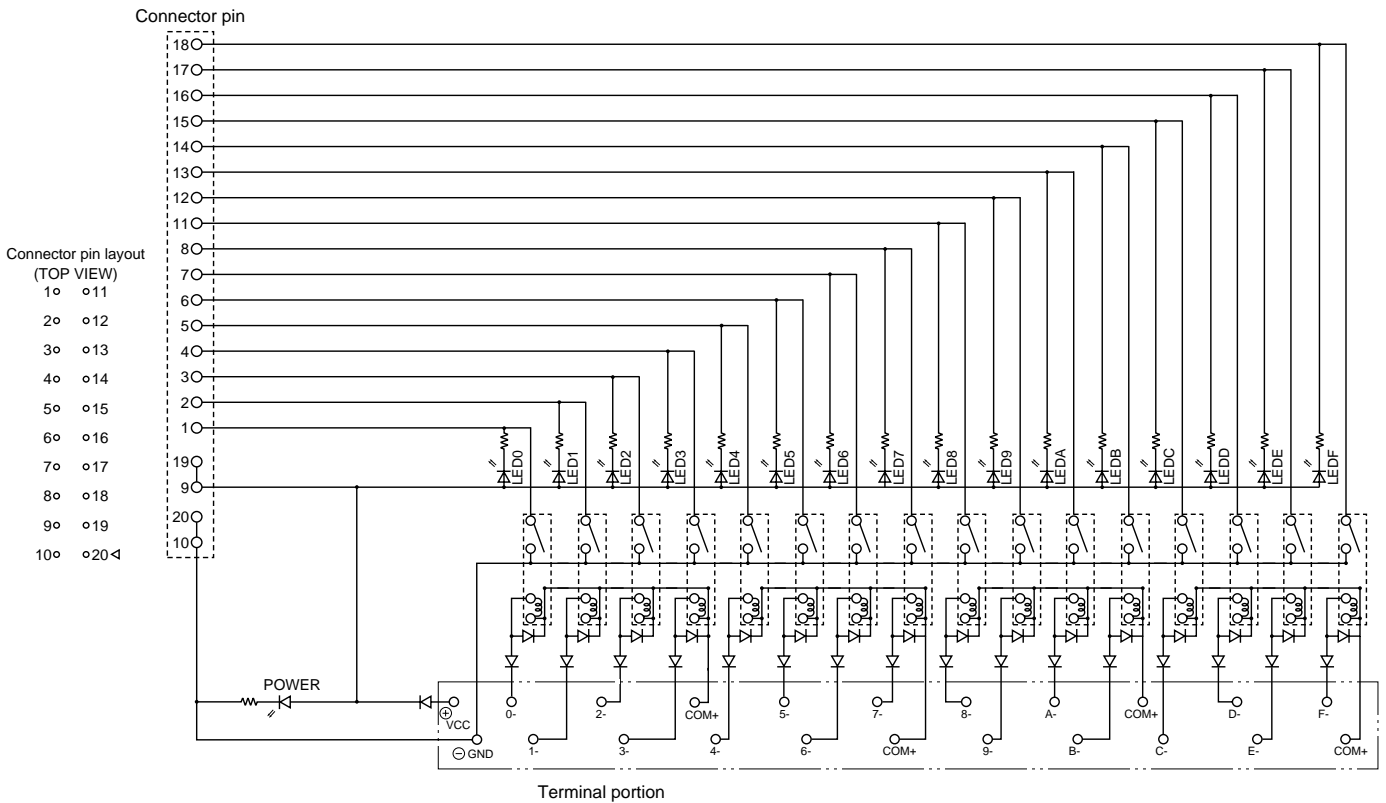

Note: Above terminal number is not marked on the terminal itself. Wiring should be done according to the Δ mark.

RT-2

Output module

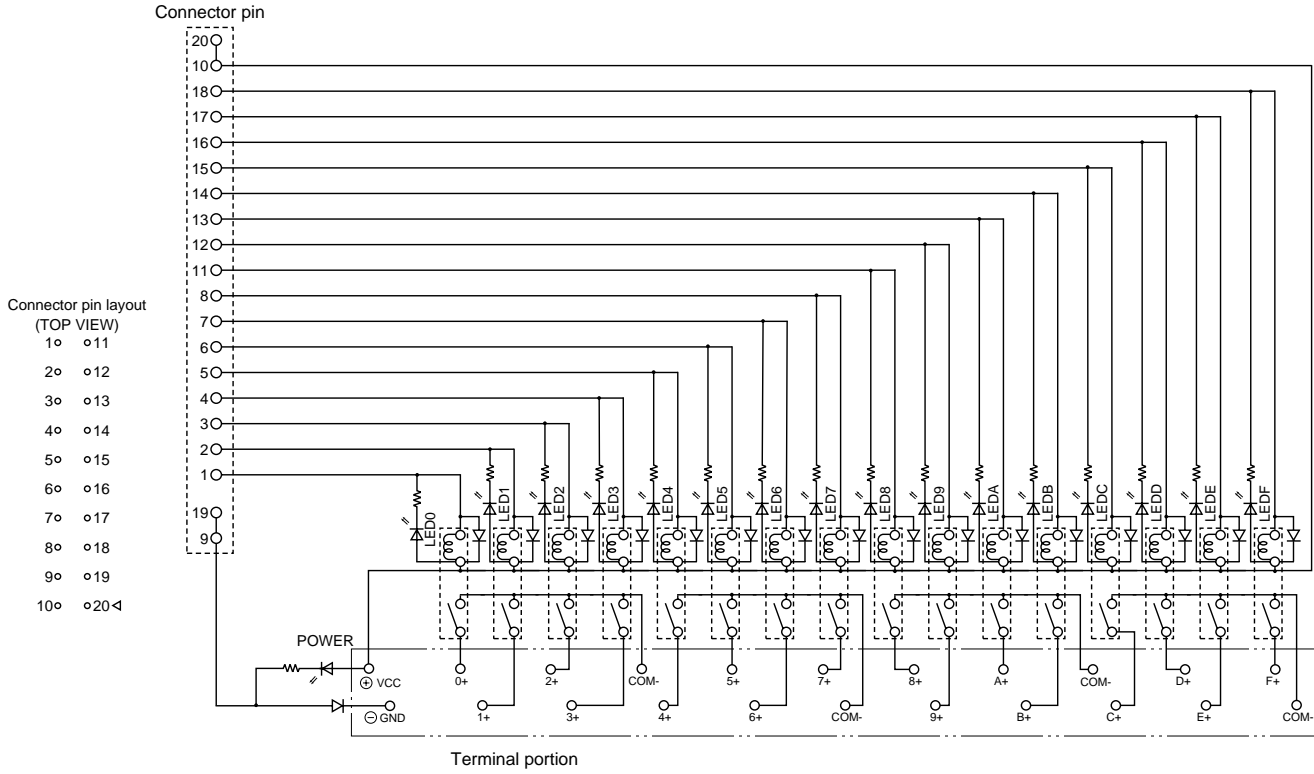

Note: Above terminal number is not marked on the terminal itself.
Wiring should be done according to the Δ mark.

2. Wire-direct connect type (Individual common)

Input module

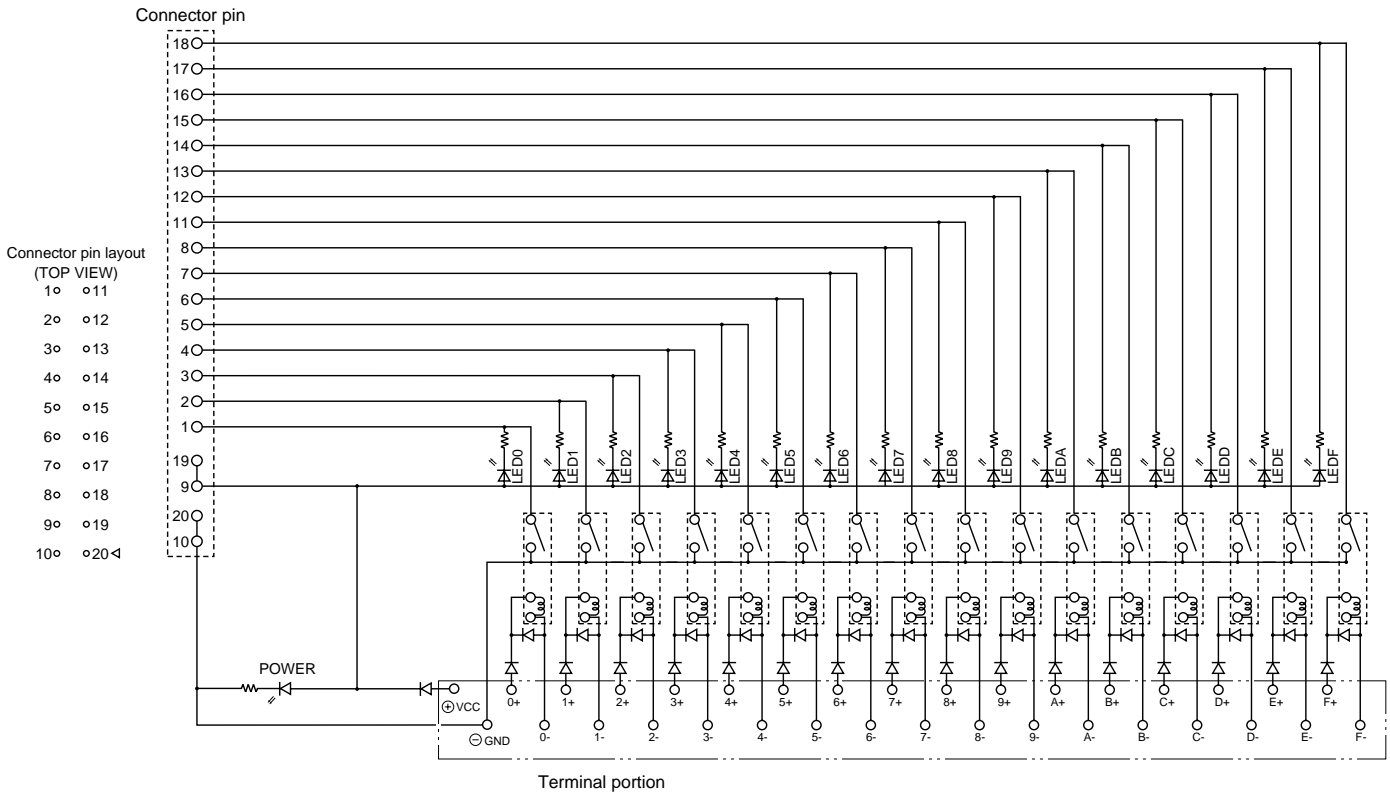

Note: Above terminal number is not marked on the terminal itself.
Wiring should be done according to the Δ mark.

Output module

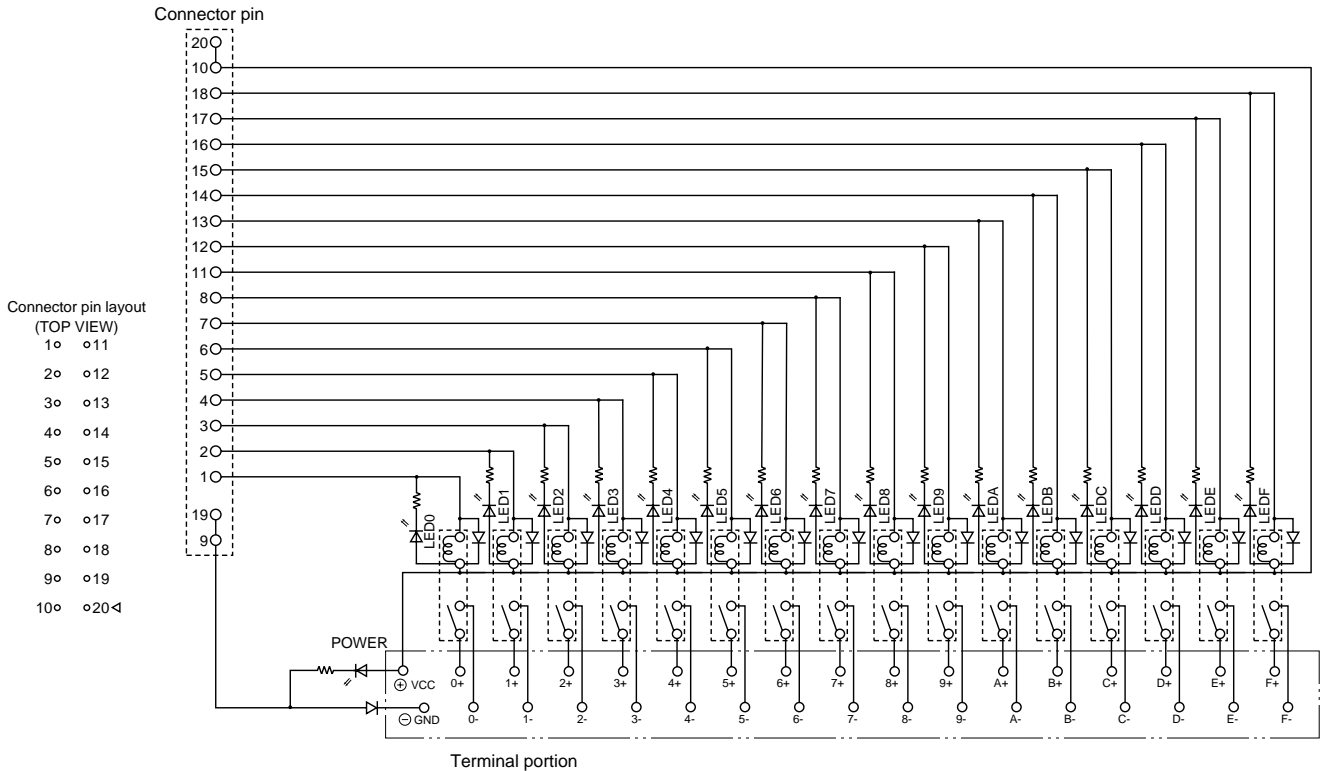

Note: Above terminal number is not marked on the terminal itself.
Wiring should be done according to the Δ mark.

CAUTIONS FOR USE

1. When equipped with Power PhotoMOS relay voltage sensitive type

Since the Power PhotoMOS relay voltage sensitive type does not require the current-controlling resistance on the input side, it can be used together with PA relays on 4-point unit relays (PA relay types) or RT-2 relay terminals.

When connecting Power PhotoMOS relay voltage sensitive types to 4-point relays (PA relay types) or RT-2 relay terminals, it will be necessary to be careful of load currents (since it will be a close connection). Be sure to use within the range given in the load currents and ambient temperature characteristics graphs given below.

• Power PhotoMOS relay (voltage sensitive type) load currents and ambient temperature characteristics

When equipped on 4-point unit relay (PA relay type) or RT-2 relay terminal.

1) DC type, 12 V input

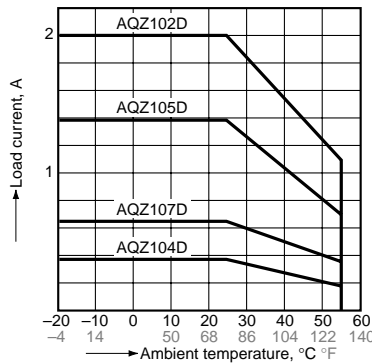

3) AC/DC type, 12 V input

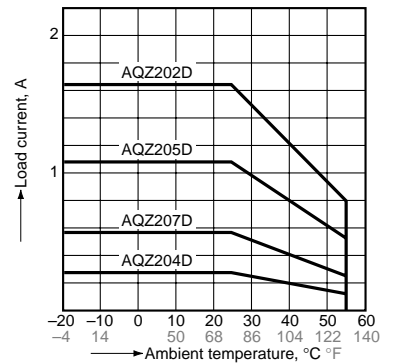

2) DC type, 24 V input

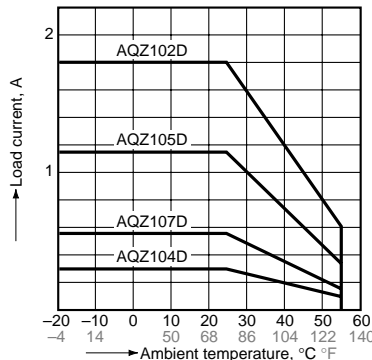

4) AC/DC type, 24 V input

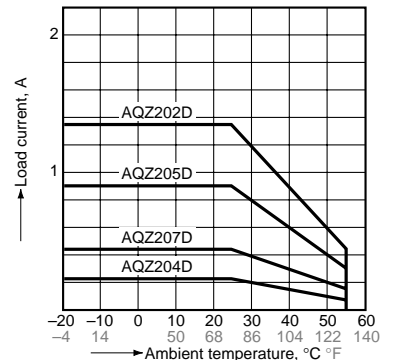

2. Operating environment

1) Use the product at ambient operating temperature between 0°C and 55°C 32°F and 131°F. (When installing in the control panel, take heat release into due consideration. Installing of the product at 90 degrees to the control panel is recommended. When installing the product horizontally or placing it on a heating unit, use a cooling fan.)

2) Keep the supply voltage within the range of 90% V to 110% V of the rated voltage.

3) Keep the product as far as possible from power cables, high tension equipment, power equipment, equipment with transmitting devices such as amateur radios, or equipment which generates a large switching surge.

4) The main unit is made of resin; therefore, do not use it in areas where it may come in contact with (or be exposed to) organic solvents such as benzene, thinner, and alcohol or strong alkaline substances such as ammonia and caustic soda.

5) Do not use the product in areas where it may be exposed to flammable gases, corrosive gases, excessive dust, or moisture, or areas where it may be subjected to strong vibration or shock.

3. Dropping

If a unit is dropped be sure to check its external appearance and characteristics before using it.

4. Installing and removing the module

1) Firmly insert the module into the socket with the terminals going in the direction of the blade receptacles.

2) The module can be easily removed using the removal key.

(1) Insert the removal key into the socket slots.

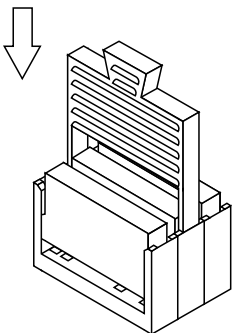

(2) Pull the removal key up to remove the module.

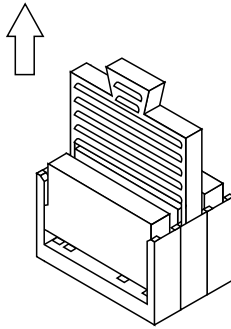

5. Wiring and circuit configuration

1) Make all connections according to the schematic. Polarity should be observed when wiring DC type.

2) Use of wire-pressed terminal is recommended for connections to pressure connector connect type. For the wire-direct connect type, strip wire ends to the specified length.

3) When wiring power lines or power cables, twisted pair treatment (stranded wire treatment) should be done in order to improve noise resistance.

4) When the load output device is an inductive load type, installing a diode and surge absorber to both ends of the load is recommended.

5) In order to improve noise resistance, class 3 grounding of the control panel is recommended.

6) Do not pass the wiring over the surface of the case. (When unavoidable, keep the wire at least 3 cm 1.181 inch away from the surface of the case.)

7) Turn off the power before connecting/disconnecting connector cables.

8) With some types of control devices, leakage current may cause the relay to fail to turn off after the control input is turned off. Make sure that the relay turns off after the control input is turned off.

6. Installation

1) Perform mounting hole cutout according to the panel cutout drawings.

2) When installing the unit on a DIN rail, use the DIN rail locking lever on the side of the unit. Installation is accomplished by simply fitting the unit onto the rail and pressing gently.

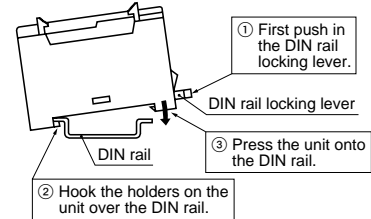

3) To remove the unit from the DIN rail, use a flat head screwdriver to pull out the DIN rail locking lever.

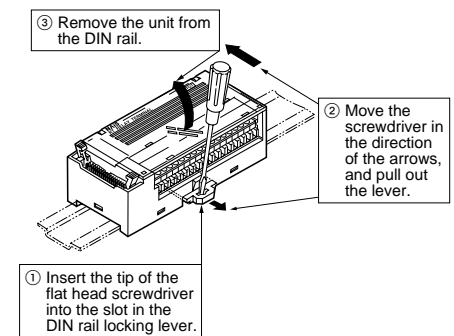

7. Transporting and storage

1) If the product is subjected to extreme vibration while being transported, the relays may become detached, the lead may become bent, and the unit may become damaged. Handle the inner and outer boxes with care.

2) If the product is stored in an extremely adverse environment, visible defects and deterioration of performance characteristics may result. We recommend the following storage conditions.

- Temperature: 5 to 30°C 41 to 86°F
- Humidity: Max. 60% R.H.
- Environment: No hazardous substances such as sulfurous acid gases and little dust.