



**SSM
2030**

VOLTAGE CONTROLLED OSCILLATOR

SSM2030 DESCRIPTION

The SSM2030 is a precision voltage controlled oscillator designed specifically to meet the waveform and accuracy requirements of electronic music systems. It has both exponential and proportional linear sweep inputs which can control frequency over a 1,000,000 to 1 range with the same capacitor. Sweep accuracy is better than 0.25% over a 1,000 to 1 range and 0.1% over 100 to 1. The device has simultaneous sawtooth, triangle and pulse outputs. An internal comparator provides control of pulse output duty cycle from 0 to 100%. Hard and soft sync inputs make possible a rich variety of modulation and harmonic locking effects.

FEATURES

- Simultaneous Exponential and Proportional Linear Sweep Inputs
- High Sweep Accuracy (0.25% 1000 to 1)
- 1,000,000 to 1 Sweep Range
- 200 kHz Max Operating Frequency
- Simultaneous Sawtooth, Triangle and Pulse Outputs
- Pulse Duty Cycle Voltage Control Range (0 to 100%)
- All Outputs Short Circuit Protected
- Hard and Soft Sync Inputs
- Max Supplies $\pm 18V$

APPLICATIONS

- Music Synthesizers
- Electronic Organs
- Electronics Games
- Waveform Generation
- V to F and F to V Conversion
- Modulation Control Circuits
- Wide Range Phase-Locked Loops
- Frequency Multiplication and Division

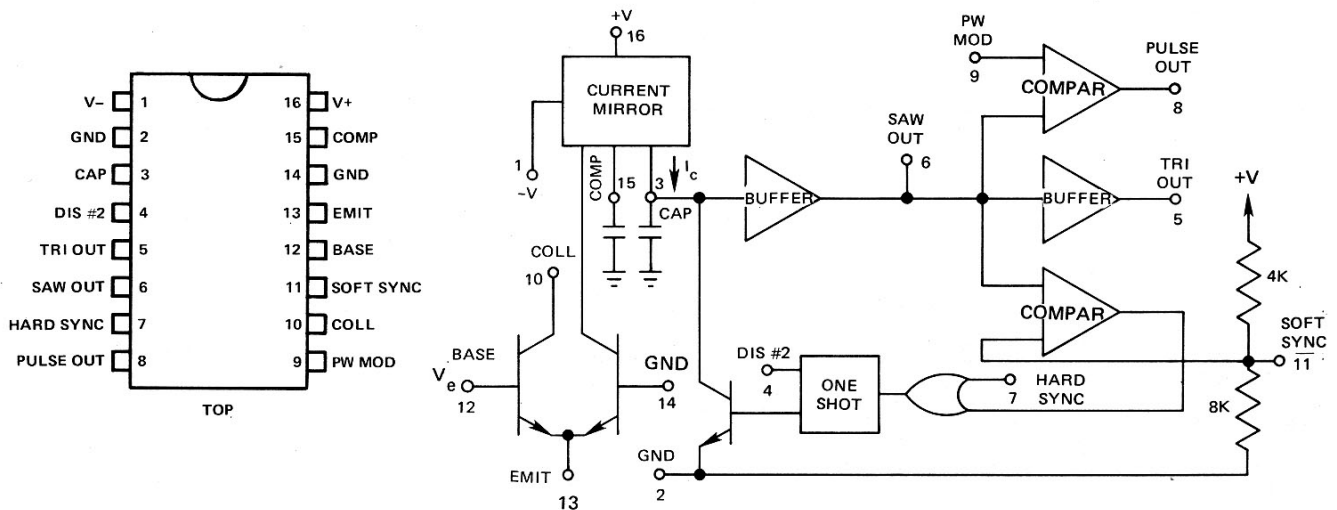

Pin Diagram

Block Diagram

SPECIFICATIONS

$V_s = \pm 15V$ AND $T_A = 25^\circ C$

STORAGE TEMPERATURE

$-55^\circ C$ to $+125^\circ C$

OPERATING TEMPERATURE

$-25^\circ C$ to $+75^\circ C$

PARAMETER	CONDITIONS	MIN	TYP	MAX
V_s		$\pm 9V$	$\pm 15V$	$\pm 18V$
Supply Current	$I_C = 1\text{ mA}$	8 mA	12 mA	16 mA
Buffer Leakage	$I_C = 0$		100 pA	1nA
Sweep Range	$C = 1000\text{ pF}$	$10^6:1$	$10^7:1$	—
Operating Frequency	$C = 1000\text{ pF}$	0.02 Hz	—	200kHz
Sawtooth Amplitude		9.5 Vpp	10 Vpp	10.5 Vpp
Pulse Amplitude		7.0 Vpp	7.5 Vpp	8.0 Vpp
Sawtooth Fall Time		—	500 nsec	—
Buffer Output		—	200 nsec	—
Buffer Input		—	—	—
Pulse Output		—	—	—
Fall Time		—	200 nsec	—
Rise Time		—	200 nsec	—
Exponential Conformity (Trimmed)				
1000:1	20Hz-20kHz, $C = 1000\text{ pF}$	—	0.25%	—
100:1	100Hz-10kHz, $C = 1000\text{ pF}$	—	0.1%	—
1000:1 Oscillator Matching	20Hz-20kHz, $C = 1000\text{ pF}$	—	0.1%	—
Linearity (Trimmed) 1000:1	20Hz-20kHz, $C = 1000\text{ pF}$, $V_e = \text{GND}$	—	0.05%	—
Output Current (before clipping)				
Sawtooth Output		1.8 mA	2.4 mA	3.4 mA
Triangle Output		1.8 mA	2.4 mA	3.4 mA
Pulse Output		3.5 mA	4.6 mA	6.5 mA
Control Circuit V_{os}	$I_e = 100\text{ }\mu\text{A}$	—	1 mV	3 mV
Power Supply Sensitivity		—	0.5%/V	1%/V
Pulse Mod Input Bias		—	1 μA	2.5 μA
Temperature Stability	$V_{PIN\ 12} = \text{GND}$	—	50ppm/ $^\circ\text{C}$	

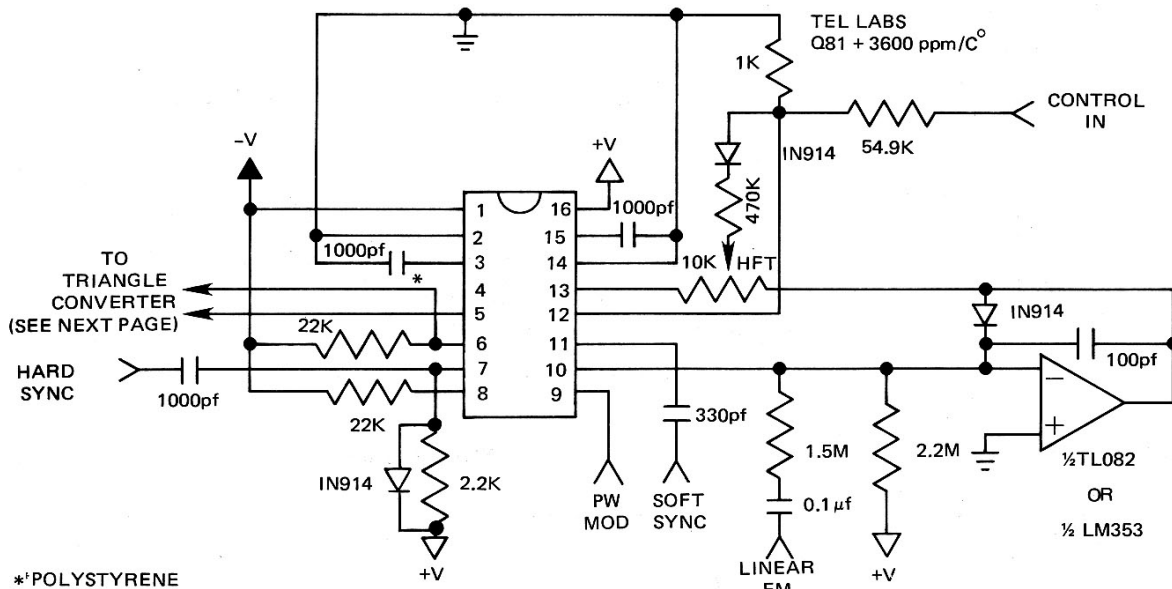

Basic Connection

*POLYSTYRENE

The frequency control circuit shown in the diagram is similar to many modular designs now in use. A low input bias op amp is used to force the current in Q_1 , to be equal to the reference current established by R_1 and the linear FM voltage (if any). The current in the output transistor Q_2 is:

$$I_o = (V_+ / R_1 + V_L / R_2) e^{-V_{be} / K T}$$

As one can see, the term in the exponent is temperature dependent. This problem can be addressed by making V_b temperature dependent.

$$\frac{d}{dT} \frac{K T}{q} = 3300 \text{ ppm}/^\circ\text{C} @ 25^\circ\text{C} \quad V_b = \frac{V_e R_3}{R_3 + R_4} \quad R_3 = 1\text{K} \quad R_4 = 54.9\text{K}$$

Since R_4 is large compared to R_3 one can use a Tel Lab type Q81 resistor (T.C. approximately 3600 ppm/ $^\circ\text{C}$) to give V_b the necessary temperature dependence. Best results are obtained with the Q81 thermally coupled to the package.

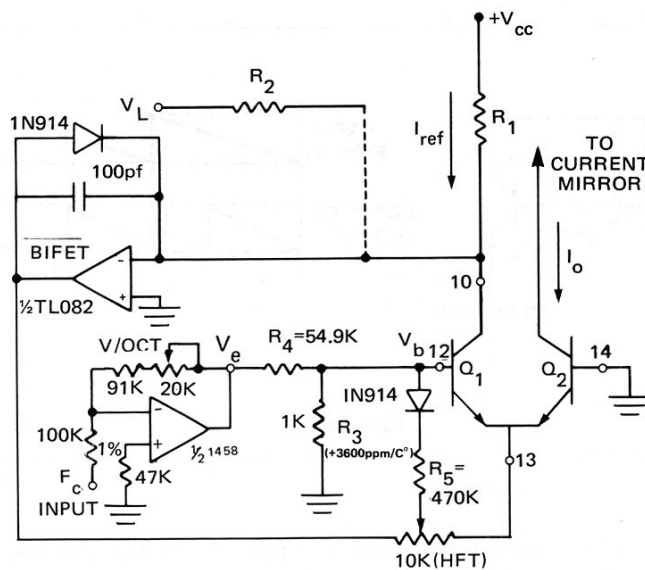

Control Circuit

VCO ADJUSTMENT PROCEDURE

The exponential control sensitivity for a music VCO is usually set for 1V/octave. The 1V/octave trim on the control summer is adjusted to give an exact change from 200Hz to 400Hz for a 1 volt change at the control summer input. The voltage at the input to the control summer is then set to give a 5kHz output frequency. The hi frequency track adjustment is then trimmed to give an exact 10kHz output frequency for a 1V change at the input.

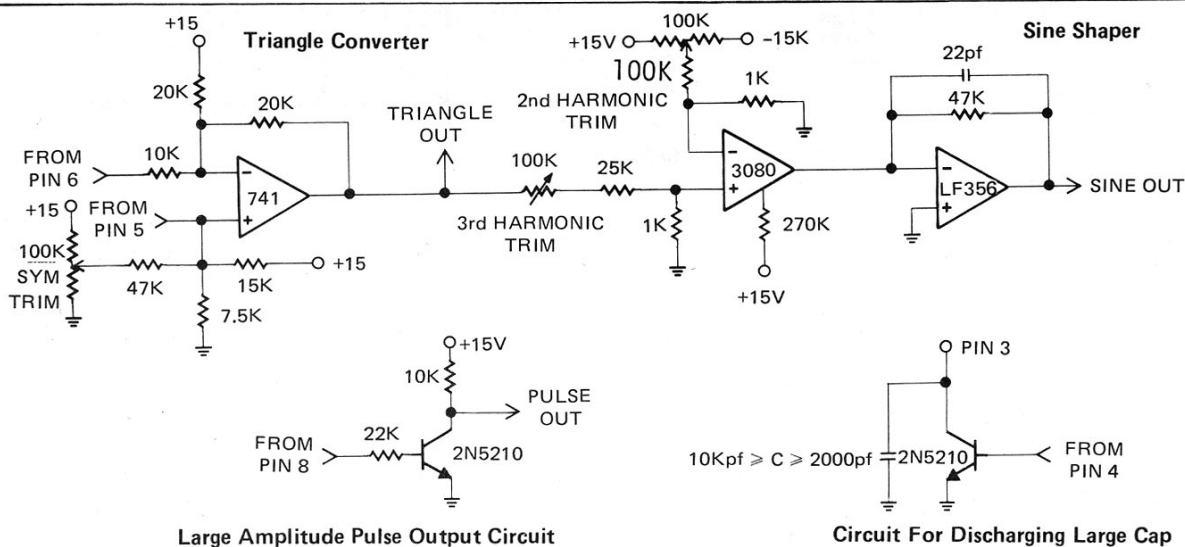

Large Amplitude Pulse Output Circuit

Circuit For Discharging Large Cap

OUTBOARD CIRCUITS

The sawtooth and "triangle" output pins are both emitter followers from the internal sawtooth. The triangle waveshaping circuit (Figure 3) uses the sawtooth output and an emitter follower from the same point which is biased to give half a sawtooth. The subtraction performed by the 1458 of the sawtooth from this waveform results in a triangle output. A true 741 type op amp must be used here, as its lower slew rate ignores the fast negative going discharge ramp which would otherwise cause a glitch at the output. A sine wave can be shaped from the triangle with a CA3080 as shown. The output has about 2% THD when trimmed.

The variable width pulse output is derived by internally comparing the sawtooth to the pulse width input. The PWM pin is thus a voltage input with a fixed 10%/V sensitivity (100% at 0 Volts decreasing to 0% at 10V). The output is -1.4V low and 6.2V high.

HARD SYNC

The hard sync input senses a falling edge, (such as another 2030's sawtooth discharge), and forces an immediate discharge of the synched 2030.

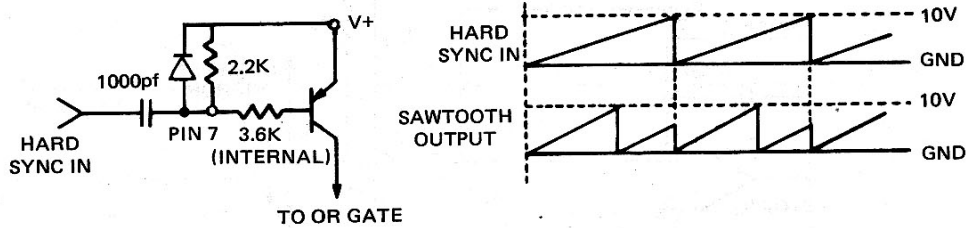

Hard Sync

SOFT SYNC

The soft sync input also accepts a falling edge but it will force discharge only if the synched 2030 is within $[240K/(R_s + 2.4K)]$ % of discharge. This enables one to phase lock two oscillators to frequencies that are exact small integer ratios of one another.

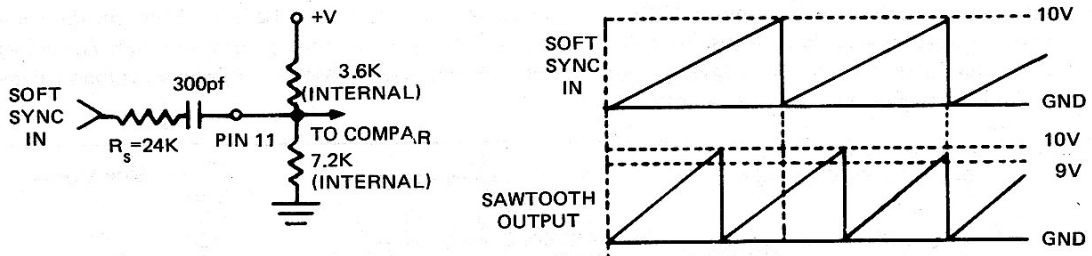

Soft Sync