

CMOS 8-Bit Microcontrollers

TMP90C041N/TMP90C041F

1. Outline and Characteristics

The TMP90C041 is a high-speed advanced 8-bit microcontroller applicable to a variety of equipment.

With its 8-bit CPU, A/D converter, multi-function timer/event counter and general-purpose serial interface integrated into a single CMOS chip, the TMP90C041 allows the expansion of external memories for programs (up to 64K byte) and data (1M byte).

The TMP90C041N is a 64-pin shrink DIP product. (SDIP64-P750)

The TMP90C041F is a 64-pin flat package product. (QFP64-P1420A)

The characteristics of the TMP90C041 include:

- (1) Powerful instructions: 163 basic instructions, including Multiplication, division, 16-bit arithmetic operations, bit manipulation instructions
- (2) Minimum instruction executing time: 320ns (at 12.5MHz oscillation frequency)
- (3) Memory expansion
External program memory: 64K byte
External data memory: 1M byte
- (4) 8-bit A/D converter (6 channels)
- (5) General-purpose serial interface (1 Channel)
Asynchronous mode, I/O interface mode
- (6) Multi-function 16-bit timer/event counter (1 channel)
- (7) 8-bit timers (4 channels)
- (8) Stepping motor control port (2 channels)
- (9) Input/Output ports (28 pins)
- (10) Interrupt function: 10 internal interrupts and 4 external interrupts
- (11) Micro Direct Memory Access (μ DMA) function (11 channels)
- (12) Watchdog timer
- (13) Standby function (4 HALT modes)

The information contained here is subject to change without notice.

The information contained herein is presented only as guide for the applications of our products. No responsibility is assumed by TOSHIBA for any infringements of patents or other rights of the third parties which may result from its use. No license is granted by implication or otherwise under any patent or patent rights of TOSHIBA or others. These TOSHIBA products are intended for usage in general electronic equipments (office equipment, communication equipment, measuring equipment, domestic electrification, etc.) Please make sure that you consult with us before you use these TOSHIBA products in equipments which require high quality and/or reliability, and in equipments which could have major impact to the welfare of human life (atomic energy control, spaceship, traffic signal, combustion control, all types of safety devices, etc.). TOSHIBA cannot accept liability to any damage which may occur in case these TOSHIBA products were used in the mentioned equipments without prior consultation with TOSHIBA.

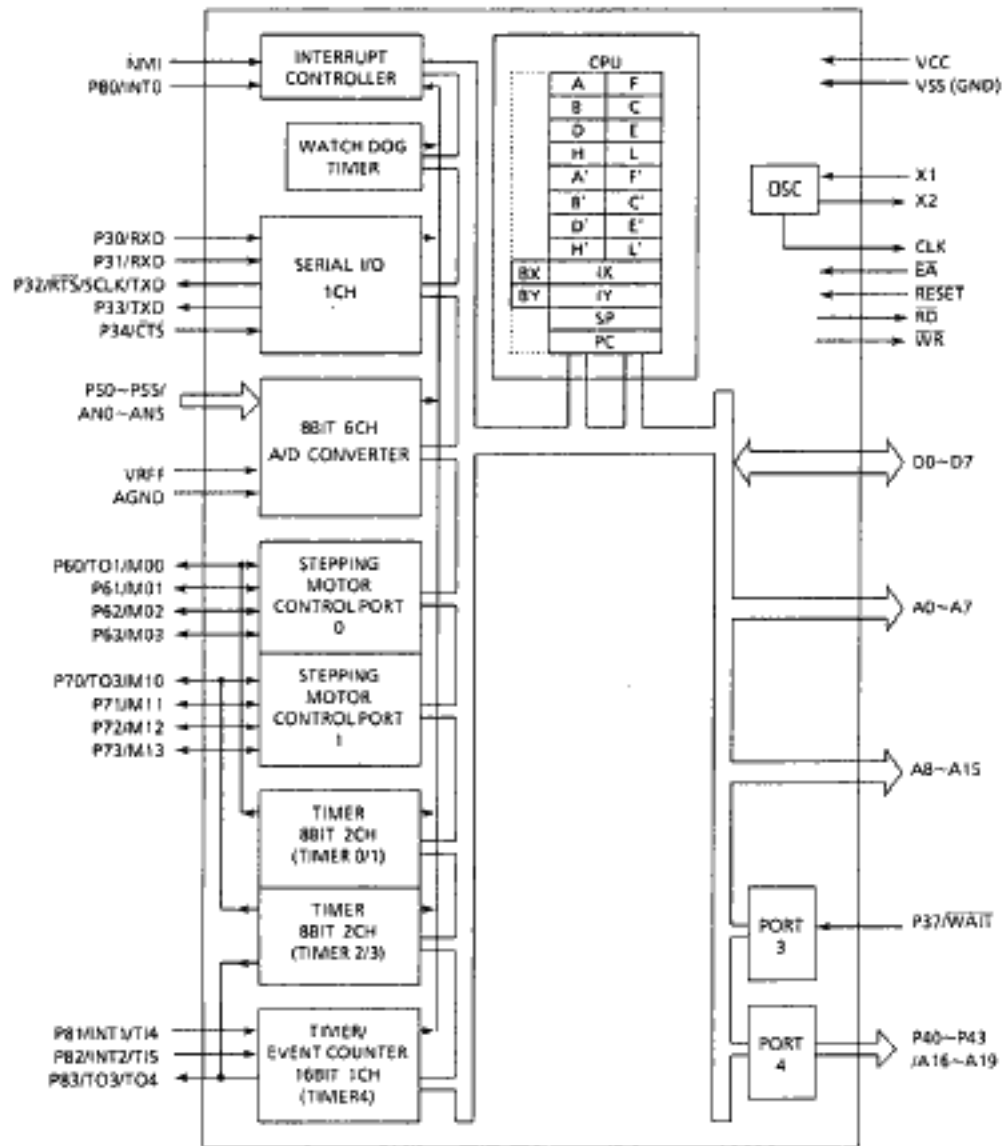

Figure 1. TMP90C041 Block Diagram

2. Pin Assignment and Functions

The assignment of input/output pins, their names and functions are described below.

2.1 Pin Assignment

Figure 2.1 (1) shows pin assignment of the TMP90C041N.

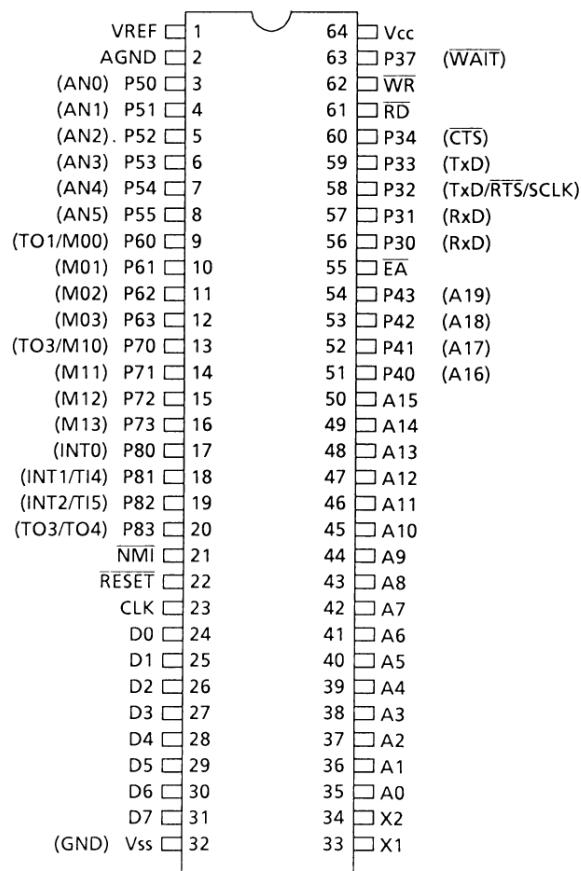

**Figure 2.1-(1). Pin Assignment
(Shrink Dual Inline Package)**

Figure 2.1 (2) shows pin assignment of the TMP90C041F.

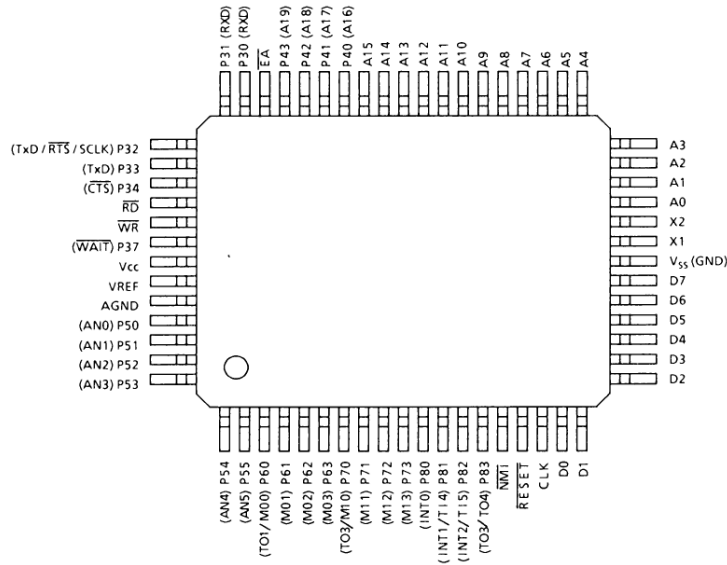

Figure 2.1 (2). Pin Assignment (Flat Package)

2.2 Pin Names and Functions



ized in Table 2.2.

The names of input/output pins and their functions are summa-

Table 2.2 Pin Names and Functions (1/2)

Pin Name	No. of pins	I/O 3 states	Function
D0 ~ D7	8	3 states	Data bus: Also functions as 8-bit bidirectional data bus for external memory
A0 ~ A7	8	Output	Address bus: The lower 8 bits address bus for external memory
A8 ~ A15	8	Output	Address bus: The upper 8 bits address bus for external memory
P30 /RxD	1	Input	Port 30: 1-bit input port Receiver Serial Data
P31 /RxD	1	Input	Port 31: 1-bit input port Receiver Serial Data
P32 /TxD /RTS /SCLK	1	Output	Port 32: 1-bit input port Transmitter Serial Data Request to send Serial Data Serial clock output
P33 /TxD	1	Output	Port 33: 1-bit output port Transmitter Serial Data
P34 /CTS	1	Input	Port 34: 1-bit input port Clear to send Serial Data
\overline{RD}	1	Output	Read: Generates strobe signal for reading external memory
\overline{WR}	1	Output	Write: Generates strobe signal for writing into external memory
P37 /WAIT	1	Input	Port 37: 1-bit input port Wait: Input pin for connecting slow speed memory or peripheral LSI

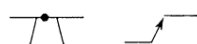
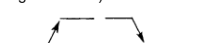
Table 2.2 Pin Names and Functions (2/2)

Pin Name	No. of Pins	I/O 3 states	Function
P40 ~ P43 /A16 ~ A19	4	Output	Port 4: 4-bit output port that allows selection of Port/Address Bus on bit basis Address bus: Also functions as address bus for external memory (4 bits of bank address)
P50 ~ P55 /AN0 ~ AN5	6	Input	Port 5: 6-bit input port Analog input: 6 analog input to A/D converter
VREF	1	–	Input of reference voltage to A/D converter
AGND	1	–	Ground pin for A/D converter
P60 ~ P63 /M00 ~ M03 /T01	4	I/O	Port 6: 4-bit I/O port that allows I/O selection on bit basis
		Output	Stepping motor control port 0
		Output	Timer output 1: Output of Timer 0 or 1
P70 ~ P73 /M10 ~ M13 /T03	4	I/O	Port 7: 4-bit I/O port that allows I/O selection on bit basis
		Output	Stepping motor control port 1
		Output	Timer output 3: Output of Timer 2 or 3
P80 /INT0	1	Input	Port 80: 1-bit input port Interrupt request pin 0: Interrupt request pin (Level/rising edge is programmable) 
P81 /INT1 /T14	1	Input	Port 81: 1-bit input port Interrupt request pin 1: Interrupt request pin (Rising/falling edge is programmable) 
			Timer input 4: Counter/capture trigger signal for Timer 4
P82 /INT2 /T15	1	Input	Port 82: 1-bit input port Interrupt request pin 2: rising edge interrupt request pin Timer input 5: capture trigger signal for Timer 4
P83 /T03/T04	1	Output	Port 83: 1-bit output port Timer output 3/4: Output of Timer 2, 3 or 4
$\overline{\text{NMI}}$	1	Input	Non-maskable interrupt request pin: Falling edge interrupt request pin 
CLK	1	Output	Clock output: Generates clock pulse at 1/4 frequency of clock oscillation. It is Pulled up internally during resetting.
$\overline{\text{EA}}$	1	Input	External access: Connects with GND pin in the TMP90C041 with no internal ROM.
$\overline{\text{RESET}}$	1	Input	Reset: Initializes the TMP90C041. (Built-in pull-up resistor)
X1/X2	2	Input/ Output	Pin for quartz crystal or ceramic resonator
V _{CC}	1	–	Power supply (+5V)
V _{SS} (GND)	1	–	Ground (0V)

3. Operation

The following explains the TMP90C041 functions and basic operations.

The CPU functions and internal I/O functions of the TMP90C041 are the same as the TMP90C840A.

Refer to the "TMP90C840A" section concerning functions which are not explained in the following.

3.1 CPU

The TMP90C041 has an internal high-performance 8-bit CPU.

Refer to the book TLCS Series CPU Core Architecture concerning CPU operation.

3.2 Memory Map

The TMP90C041 supports a program memory of up to 64K bytes and a data memory of maximum 1M bytes.

The program memory may be assigned to the address space from 00000H to 0FFFFH, while the data memory can be allocated to any address from 00000H to FFFFFH.

- (1) Internal I/O

The TMP90C041 provides a 48-byte address space as an internal I/O area, whose addresses range from FFC0H to FFEFH. This I/O area can be accessed by the CPU using a short opcode in the "direct addressing mode".

Figure 3.1 is a memory map indicating the areas accessible by the CPU in the respective addressing

mode.

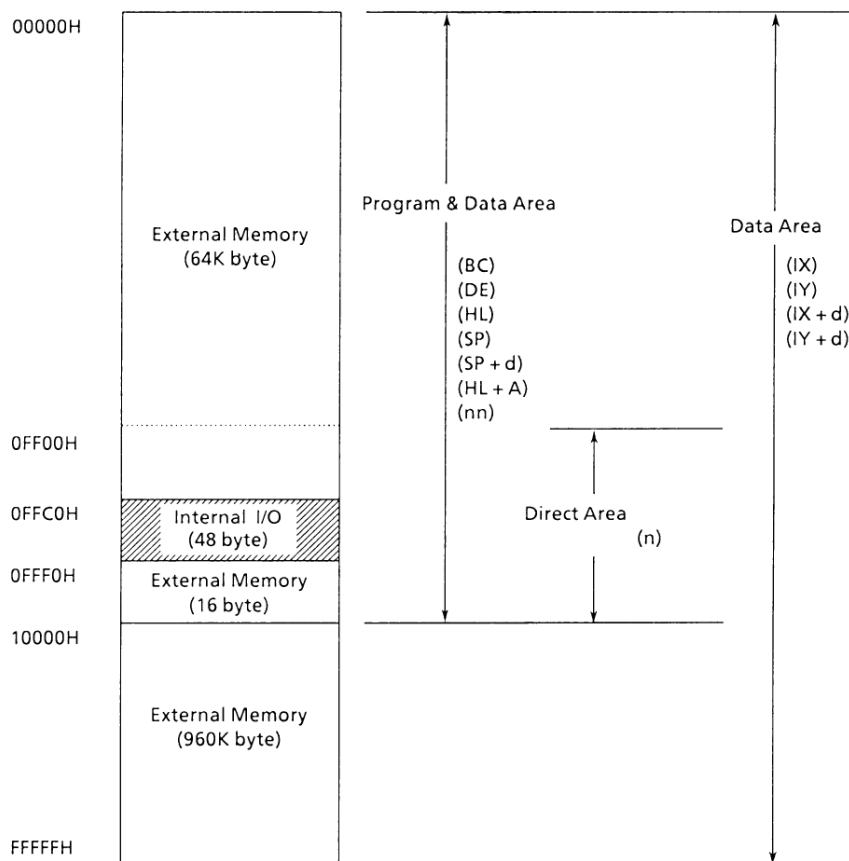

Figure 3.2. Memory Map

4. Electrical Characteristics

TMP90C041N/TMP90C041F

4.1 Absolute Maximum Ratings

Symbol	Parameter	Rating	Unit
V_{CC}	Supply voltage	-0.5 ~ +7	V
V_{IN}	Input voltage	-0.5 ~ $V_{CC} + 0.5$	V
P_D	Power dissipation ($T_a = 70^\circ\text{C}$)	F 500	mW
		N 600	
T_{SOLDER}	Soldering temperature (10s)	260	$^\circ\text{C}$
T_{STG}	Storage temperature	-65 ~ 150	$^\circ\text{C}$
T_{OPR}	Operating temperature	-20 ~ 70	$^\circ\text{C}$

4.2 DC Characteristics

$T_A = -20 \sim 70^\circ\text{C}$ $V_{CC} = 5V \pm 10\%$
Typical Values are for $T_A = 25^\circ\text{C}$ and $V_{CC} = 5V$.

Symbol	Parameter	Min	Max	Unit	Test Conditions
V_{IL}	Input Low Voltage (D0 ~ D7)	-0.3	$0.2V_{CC} - 0.1$	V	–
V_{IL1}	P3, P5, P6, P7, P8	-0.3	$0.3V_{CC}$	V	–
V_{IL2}	$\overline{\text{RESET}}$, INTO, $\overline{\text{NMI}}$	-0.3	$0.25V_{CC}$	V	–
V_{IL4}	X1	-0.3	$0.2V_{CC}$	V	–
V_{IH}	Input High Voltage (D0 ~ D7)	$0.2V_{CC} + 1.1$	$V_{CC} + 0.3$	V	–
V_{IH1}	P3, P5, P6, P7, P8	$0.7V_{CC}$	$V_{CC} + 0.3$	V	–
V_{IH2}	$\overline{\text{RESET}}$, INTO, NMI	$0.75V_{CC}$	$V_{CC} + 0.3$	V	–
V_{IH4}	X1	$0.8V_{CC}$	$V_{CC} + 0.3$	V	–
V_{OL}	Output Low Voltage	–	0.45	V	$I_{OL} = 1.6\text{mA}$
V_{OH} V_{OH1} V_{OH2}	Output High Voltage	2.4 $0.75V_{CC}$ $0.9V_{CC}$	–	V V V	$I_{OH} = -400\mu\text{A}$ $I_{OH} = -100\mu\text{A}$ $I_{OH} = -20\mu\text{A}$
I_{DAR}	Darlington Drive Current (8 I/O pins)	-1.0	-3.5	mA	$V_{EXT} = 1.5V$ $R_{EXT} = 1.1k\Omega$
I_{LI}	Input Leakage Current	0.02 (Typ)	± 5	μA	$0.0 \leq V_{in} \leq V_{CC}$
I_{LO}	Output Leakage Current	0.05 (Typ)	± 10	μA	$0.2 \leq V_{in} \leq V_{CC} - 0.2$
I_{CC}	Operating Current (RUN)	20 (Typ)	40	mA	$t_{osc} = 12.5\text{MHz}$
	Idle 1	1.5 (Typ)	5	mA	
	Idle 2	9 (Typ)	15	mA	
	STOP ($T_A = -20 \sim 70^\circ\text{C}$)	0.2 (Typ)	50	μA	$0.2 \leq V_{in} \leq V_{CC} - 0.2$
	STOP ($T_A = 0 \sim 50^\circ\text{C}$)		10	μA	
R_{RST}	$\overline{\text{RESET}}$ Pull Up Register	50	150	$k\Omega$	–
CIO	Pin Capacitance	–	10	pF	testfreq = 1MHz
V_{TH}	Schmitt width $\overline{\text{RESET}}$, NMI, INTO	0.4	1.0 (Typ)	V	–

Note: I_{DAR} is guaranteed for a total of up to 8 optional ports.

4.3 AC Characteristics

TA = -20 ~ 70°C V_{CC} = 5V ± 10%
CL = 50pF

Symbol	Parameter	Variable		10MHz Clock		12.5MHz Clock		Unit
		Min	Max	Min	Max	Min	Max	
t _{OSC}	OSC. Period = x	80	1000	100	-	80	-	ns
t _{CYC}	CLK Period	4x	4x	400	-	320	-	ns
t _{WL}	CLK Low width	2x - 40	-	160	-	120	-	ns
t _{WH}	CLK High width	2x - 40	-	160	-	120	-	ns
t _{AC}	Address Setup to \overline{RD} , \overline{WR}	x - 45	-	55	-	35	-	ns
t _{RR}	\overline{RD} Low width	2.5x - 40	-	210	-	160	-	ns
t _{CA}	Address Hold Time After \overline{RD} , \overline{WR}	0.5x - 30	-	20	-	10	-	ns
t _{AD}	Address to Valid Data In	-	3.5x - 95	-	255	-	185	ns
t _{RD}	\overline{RD} to Valid Data In	-	2.5x - 80	-	170	-	120	ns
t _{HR}	Input Data Hold After \overline{RD}	0	-	0	-	0	-	ns
t _{WW}	\overline{WR} Low width	2.5x - 40	-	210	-	160	-	ns
t _{DW}	Data Setup to \overline{WR}	2x - 50	-	150	-	110	-	ns
t _{WD}	Data Hold After \overline{WR}	30	90	30	90	30	90	ns
t _{CWA}	\overline{RD} , \overline{WR} to Valid \overline{WAIT}	-	1.5x - 100	-	50	-	20	ns
t _{AWA}	Address to Valid \overline{WAIT}	-	2.5x - 130	-	120	-	70	ns
t _{WAS}	\overline{WAIT} Setup to CLK	70	-	70	-	70	-	ns
t _{WAH}	\overline{WAIT} Hold After CLK	0	-	0	-	0	-	ns
t _{RV}	$\overline{RD}/\overline{WR}$ Recovery Time	1.5x - 35	-	115	-	85	-	ns
t _{CPW}	CLK to Port Data Output	-	x + 200	-	300	-	280	ns
t _{PRC}	Port Data Setup to CLK	200	-	200	-	200	-	ns
t _{CPR}	Port Data Hold After CLK	100	-	100	-	100	-	ns
t _{CHCL}	$\overline{RD}/\overline{WR}$ Hold After CLK	x-60	-	40	-	20	-	ns
t _{CLC}	$\overline{RD}/\overline{WR}$ Setup to CLK	1.5x - 25	-	100	-	70	-	ns
t _{CLHA}	Address Hold After CLK	1.5x - 80	-	70	-	40	-	ns
t _{ACL}	Address Setup to CLK	2.5x - 80	-	170	-	120	-	ns
t _{CLD}	Data Setup to CLK	x - 50	-	50	-	30	-	ns

- AC output level High 2.2V/Low 0.8V
- AC input level High 2.4V/Low 0.45V (D0 – D7)
High 0.8V_{CC}/Low 0.2V_{CC} (excluding D0 – D7)

4.4 A/D Conversion Characteristics

TA = -20 ~ 70°C V_{CC} = 5V ± 10%

Symbol	Parameter	Min	Typ	Max	Unit
V _{REF}	Analog reference voltage	V _{CC} - 1.5	V _{CC}	V _{CC}	V
A _{GN} D	Analog reference voltage	V _{SS}	V _{SS}	V _{SS}	
V _{AIN}	Allowable analog input voltage	V _{SS}	–	V _{CC}	
I _{REF}	Supply current for analog reference voltage	–	0.5	1.0	mA
Error	Total error (TA = 25°C, V _{CC} = V _{REF} = 5.0V)	–	–	1.0	LSB
	Total error	–	–	2.5	

4.5 Zero-Cross Characteristics

TA = -20 ~ 70°C V_{CC} = 5V ± 10%

Symbol	Parameter	Condition	Min	Max	Unit
V _{ZX}	Zero-cross detection input	AC coupling C = 0.1μF	1	1.8	VAC p - p
A _{ZX}	Zero-cross accuracy	50/60Hz sine wave	–	135	mV
F _{ZX}	Zero-cross detection input frequency	–	0.04	1	kHz

4.6 Serial Channel Timing-I/O Interface Mode

TA = -20 ~ 70°C V_{CC} = 5V ± 10%
CL = 50pF

Symbol	Parameter	Variable		10MHz Clock		12.5MHz Clock		Unit
		Min	Max	Min	Max	Min	Max	
t _{SCY}	Serial Port Clock Cycle Time	8x	–	800	–	640	–	ns
t _{OSS}	Output Data Setup SCLK Rising Edge	6x - 150	–	450	–	330	–	ns
t _{OHS}	Output Data Hold After SCLK Rising Edge	2x - 120	–	80	–	40	–	ns
t _{HSR}	Input Data Hold After SCLK Rising Edge	0	–	0	–	0	–	ns
t _{SRD}	SCLK Rising Edge to Input DATA Valid	–	6x - 150	–	450	–	330	ns





4.7 16-bit Event Counter

TA = -20 ~ 70°C V_{CC} = 5V ± 10%

Symbol	Parameter	Variable		10MHz Clock		12.5MHz Clock		Unit
		Min	Max	Min	Max	Min	Max	
t _{VCK}	Tl4 clock cycle	8x + 100	–	900	–	740	–	ns
t _{VCKL}	Tl4 Low clock pulse width	4x + 40	–	440	–	360	–	ns
t _{VCKH}	Tl4 High clock pulse width	4x + 40	–	440	–	360	–	ns

4.8 Interrupt Operation

TA = -20 ~ 70°C V_{CC} = 5V ± 10%

Symbol	Parameter	Variable		10MHz Clock		12.5MHz Clock		Unit
		Min	Max	Min	Max	Min	Max	
t _{INTAL}	NMI, INTO Low level pulse width 	4x	-	400	-	320	-	ns
t _{INTAH}	NMI, INTO High level pulse width 	4x	-	400	-	320	-	ns
t _{INTBL}	INT1, INT2 Low level pulse width 	8x + 100	-	900	-	740	-	ns
t _{INTBH}	INT1, INT2 High level pulse width 	8x + 100	-	900	-	740	-	ns

(Reference) Definition of I_{DAR}

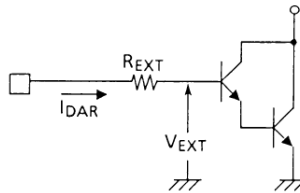

4.9 I/O Interface Mode Timing Chart

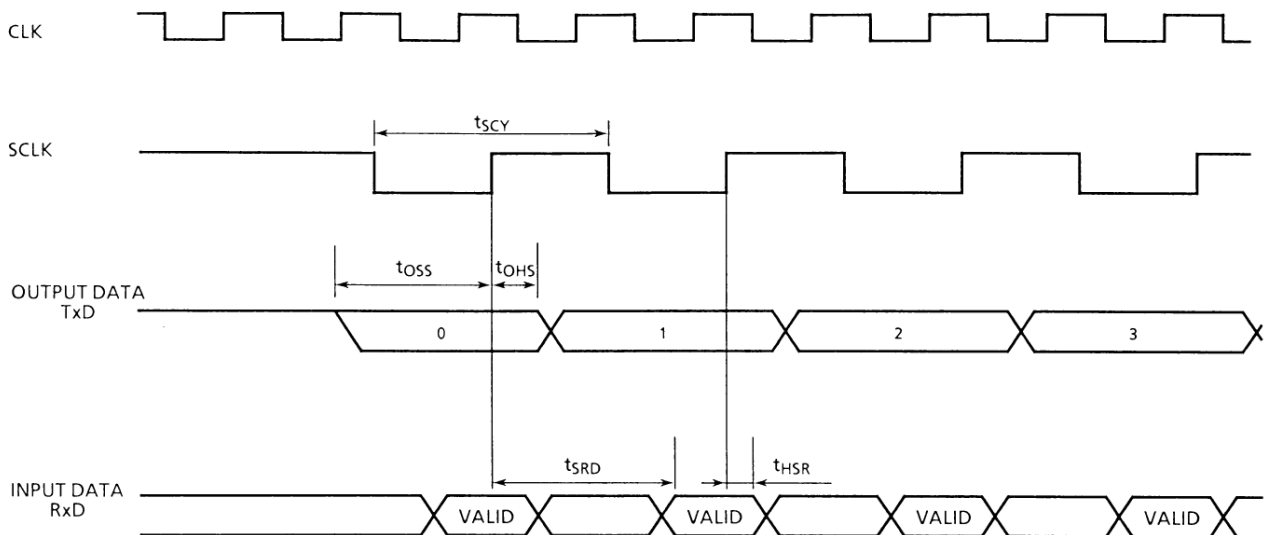

4.10 Timing Chart

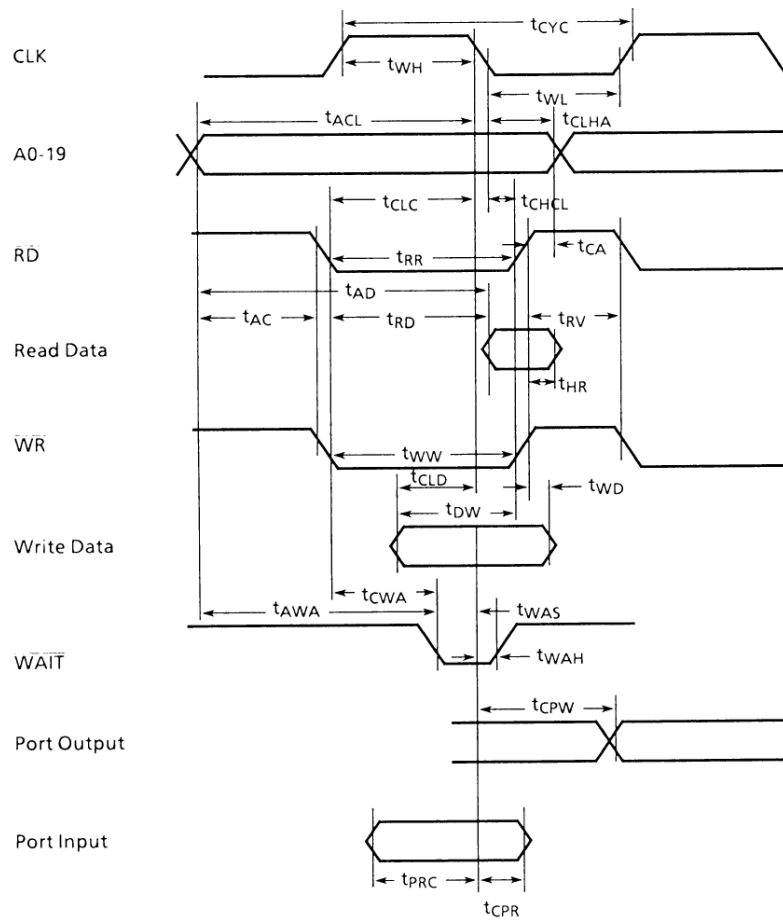

5. Differences Between TMP90C841A and TMP90C041

Specifications of TMP90C841A and TMP90C041 are the same except below.

TMP90C841A system, not using internal RAM and

internal I/O functions as shown below, can be substituted by TMP90C041 system. To substitute the TMP90C841A system using the internal RAM by the TMP90C041 system, it is necessary to attach the external RAM to the address corresponded to the internal address.

Name	TMP90C841A	TMP90C041
RAM	256 bytes of internal RAM are provided. (0FEC0H ~ 0FFBFH)	External memory area.
A0 ~ A15	High-Impedance state during reset	Driving state during reset.
P0 (0FFC1H) P1 (0FFC1H) P2 (0FFC4H)	Provided (same chip as TMP90C840A)	R/W function is not provided.
P01CR (0FFC2H)	Provided	EXT, P1C, P0C is not provided.
P2CR (0FFC5H)	Provided	P2XC register is not provided

* Note: Connect \overline{EA} pin with GND pin.