

Agilent HDMP-0450 Quad Port Bypass Circuit for Fibre Channel Arbitrated Loops Data Sheet

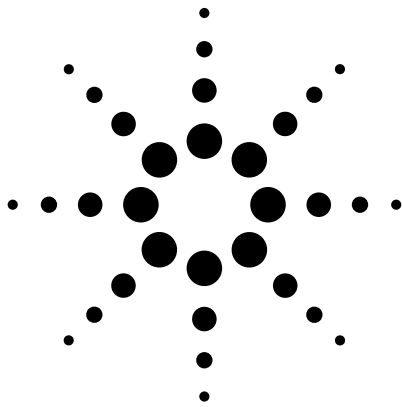

Description

The HDMP-0450 is a Quad Port Bypass Circuit (PBC) which provides a low-cost, low-power physical-layer solution for Fibre Channel Arbitrated Loop (FC-AL) disk array configurations. By using a PBC such as the HDMP-0450, hard disks may be pulled out or swapped while other disks in the array are available to the system.

A PBC consists of multiple 2:1 multiplexers daisy chained together. Each port has two modes of operation: “disk in loop” and “disk bypassed.” When the “disk in loop” mode is selected, the loop goes into and out of the disk drive at that port. For example, data goes from the HDMP-0450’s TO_NODE[n]± differential output pins to the Disk Drive Transceiver IC’s (e.g., an HDMP-1636A) Rx differential input pins. Data from the Disk Drive Transceiver IC’s Tx differential outputs goes to the HDMP-0450’s FM_NODE[n]± differential input

pins. Figure 2 shows connection diagrams for disk drive array applications. When the “disk bypassed” mode is selected, the disk drive is either absent or nonfunctional and the loop bypasses the hard disk.

The “disk bypassed” mode is enabled by pulling the BYPASS[n]- pin low. Leave BYPASS[n]- floating to enable the “disk in loop” mode. HDMP-0450s may be cascaded with other members of the HDMP-04XX/HDMP-05XX family through the appropriate FM_NODE[n]± and TO_NODE[n]± pins to accommodate any number of hard disks (see Figure 3). The unused cells in the HDMP-0450 may be bypassed by using pulldown resistors on the BYPASS[n]- pins for these cells.

An HDMP-0450 may also be configured as five 1:1 buffers, as two 2:1 multiplexers, or as two 1:2 buffers.

Features

- Supports 1.0625 GBd Fibre Channel operation
- Supports 1.25 GBd Gigabit Ethernet (GE) operation
- Quad PBC in one package
- Signal detect on FM_NODE[0] input
- Equalizers on all inputs
- High speed LVPECL I/O
- Buffered Line Logic (BLL) outputs (no external bias resistors required)
- 0.5 W typical power at $V_{CC} = 3.3 V$
- 44 Pin, 10 mm, low-cost plastic QFP package

Applications

- RAID, JBOD, BTS cabinets
- Two 2:1 muxes
- Two 1:2 buffers
- 1 => N gigabit serial buffer
- N => 1 gigabit serial mux

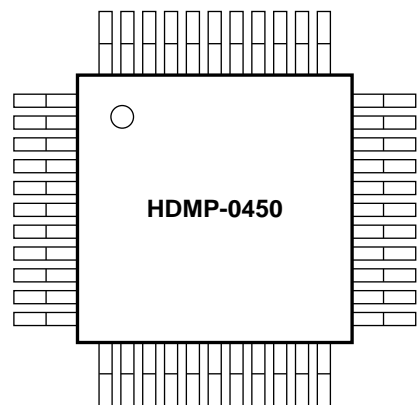

CAUTION: As with all semiconductor ICs, it is advised that normal static precautions be taken in the handling and assembly of this component to prevent damage and/or degradation which may be induced by electrostatic discharge (ESD).



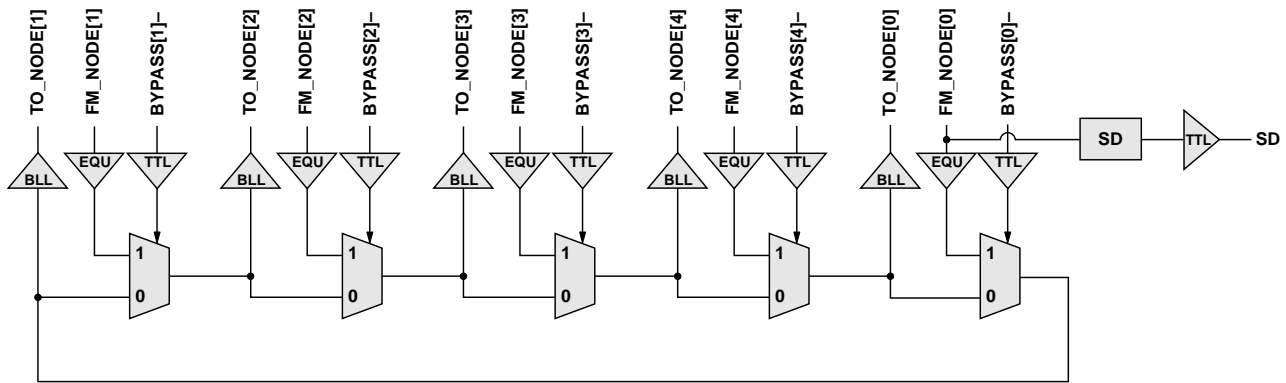

Figure 1. Block diagram of HDMP-0450.

HDMP-0450 Block Diagram

BLL OUTPUT

All TO_NODE[n] \pm high-speed differential outputs are driven by a Buffered Line Logic (BLL) circuit that has on-chip source termination, so no external bias resistors are required. The BLL outputs on the HDMP-0450 are of equal strength and can drive in lengthy FR-4 PCB trace.

Unused outputs should not be left unconnected. Ideally, unused outputs should have their differential pins shorted together with a short PCB trace. If longer traces or transmission lines are connected to the output pins, the lines should be differentially terminated with an appropriate resistor. The value of the termination resistor should match the PCB trace differential impedance.

EQU INPUT

All FM_NODE[n] \pm high-speed differential inputs have an Equalization (EQU) buffer to offset the effects of skin loss and dispersion on PCBs. An external termination resistor is required across all high-speed inputs. The value of the termination resistor should match the PCB trace differential impedance. Alternatively, instead of a single resistor, two resistors in series, with an AC ground between them, can be connected differentially across the FM_NODE[n] \pm inputs. The latter configuration attenuates high-frequency common mode noise.

BYPASS[n]- INPUT

The active low BYPASS[n]- inputs control the data flow through the HDMP-0450. All BYPASS pins are LVTTTL and contain internal pull-up circuitry. To bypass a port,

the appropriate BYPASS[n]- pin should be connected to GND through a 1 k Ω resistor. Otherwise, the BYPASS[n]-inputs should be left to float, as the internal pull-up circuitry will force them high.

SD OUTPUT

The Signal Detect (SD) block detects if the incoming data on FM_NODE[0] \pm is valid by examining the differential amplitude of that input. The incoming data is considered valid, and SD is driven high, as long as the amplitude is greater than 400 mV (differential peak-to-peak). SD is driven low as long as the amplitude of the input signal is less than 100 mV (differential peak-to-peak). When the amplitude of the input signal is between 100-400 mV (differential peak-to-peak), the SD output is undefined.

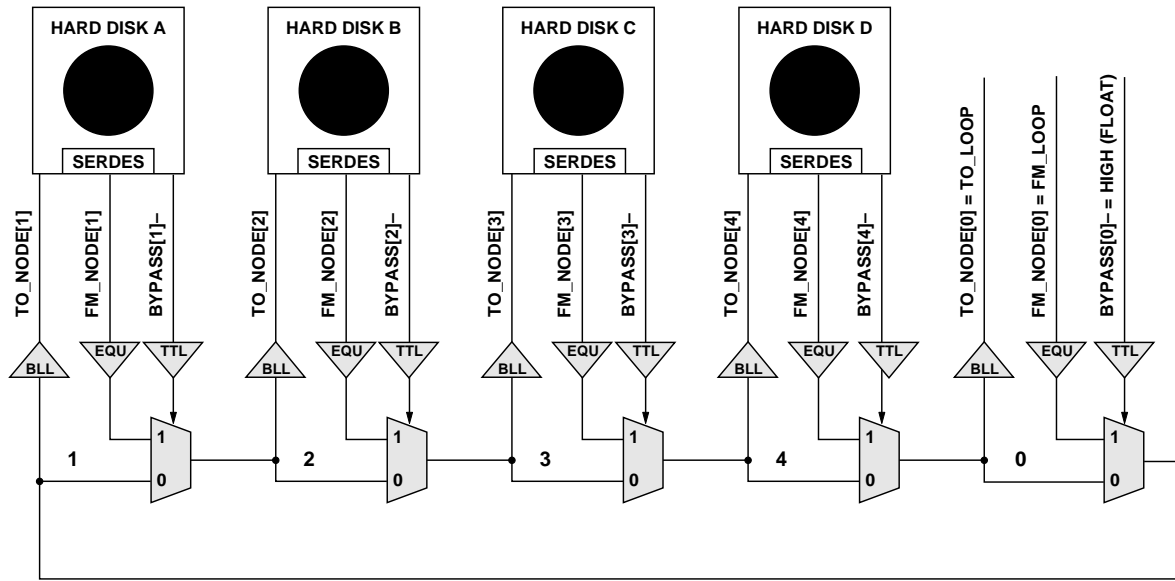

Figure 2. Connection diagram for Disk Array applications.

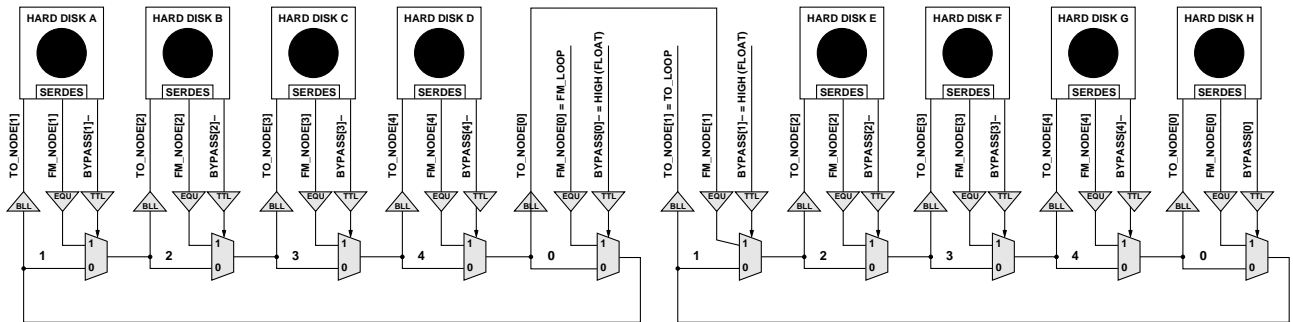

Figure 3. Connection diagram for multiple HDMP-0450s.

I/O Type Definitions

I/O Type	Definition
I-LVTTL	LVTTL Input
O-LVTTL	LVTTL Output
HS_OUT	High Speed Output. LVPECL Compatible
HS_IN	High Speed Input
C	External Circuit Note
S	Power Supply or Ground

Pin Definitions

Pin Name	Pin	Pin Type	Pin Description
TO_NODE[0]+	24	HS_OUT	Serial Data Outputs: High-speed outputs to a hard disk drive or to a cable.
TO_NODE[0]-	25		
TO_NODE[1]+	07		
TO_NODE[1]-	06		
TO_NODE[2]+	44		
TO_NODE[2]-	43		
TO_NODE[3]+	38		
TO_NODE[3]-	37		
TO_NODE[4]+	31		
TO_NODE[4]-	30		
FM_NODE[0]+	10	HS_IN	Serial Data Inputs: High-speed inputs from a hard disk drive or from a cable.
FM_NODE[0]-	09		
FM_NODE[1]+	04		
FM_NODE[1]-	03		
FM_NODE[2]+	41		
FM_NODE[2]-	40		
FM_NODE[3]+	35		
FM_NODE[3]-	34		
FM_NODE[4]+	28		
FM_NODE[4]-	27		
BYPASS[0]-	14	I-LVTTL	Bypass Inputs: For “disk bypassed” mode, connect BYPASS[n]- to GND through a 1 k Ω resistor. For “disk in loop” mode, float HIGH.
BYPASS[1]-	15		
BYPASS[2]-	16		
BYPASS[3]-	17		
BYPASS[4]-	18		
SD	20	O-LVTTL	Signal Detect: Indicates acceptable signal amplitude on the FM_NODE[0] \pm inputs. If (FM_NODE[0]+ – FM_NODE[0]-) \geq 400 mV peak-to-peak, SD = 1 If 400 mV > (FM_NODE[0]+ – FM_NODE[0]-) > 100 mV, SD = undefined If 100 mV \geq (FM_NODE[0]+ – FM_NODE[0]-), SD = 0

Pin Definitions, continued

GND	01 08 11 12 13 19 22 23 33 39	S	Ground: Normally 0 volts. See Figure 9 for Recommended Power Supply Filtering.
VCCHS[0]	26	S	High Speed Supply: Normally 3.3 volts. Used only for high-speed outputs (TO_NODE[n]). See Figure 9 for Recommended Power Supply Filtering.
VCCHS[1]	05	S	
VCCHS[2]	42	S	
VCCHS[3]	36	S	
VCCHS[4]	29	S	
VCC	02 21 32	S	Logic Power Supply: Normally 3.3 volts. Used for internal logic. See Figure 9 for Recommended Power Supply Filtering.

Absolute Maximum Ratings

$T_A = 25^\circ\text{C}$, except as specified. Operation in excess of any of these conditions may result in permanent damage to this device. Continuous operation at these minimum or maximum ratings is not recommended.

Symbol	Parameter	Units	Min.	Max.
V_{CC}	Supply Voltage	V	-0.5	4.0
$V_{IN,LVTTL}$	LVTTL Input Voltage	V	-0.5	$V_{CC} + 0.5^{[1]}$
V_{IN,HS_IN}	HS_IN Input Voltage (Differential)	mV	200	2000
$I_{O,LVTTL}$	LVTTL Output Sink/Source Current	mA		± 13
T_{stg}	Storage Temperature	$^\circ\text{C}$	-65	+150
T_j	Junction Temperature	$^\circ\text{C}$	0	+125

Note:

1. Must remain less than or equal to absolute maximum V_{CC} voltage of 4.0 V.

DC Electrical Specifications

$V_{CC} = 3.15\text{ V to }3.45\text{ V}$

Symbol	Parameter	Units	Min.	Typ.	Max.
$V_{IH,LVTTL}$	LVTTL Input High Voltage Range	V	2.0		
$V_{IL,LVTTL}$	LVTTL Input Low Voltage Range	V			0.8
$V_{OH,LVTTL}$	LVTTL Output High Voltage Range, $I_{OH} = -400\ \mu\text{A}$	V	2.2		V_{CC}
$V_{OL,LVTTL}$	LVTTL Output Low Voltage Level, $I_{OL} = 1\ \text{mA}$	V	0		0.6
$I_{IH,LVTTL}$	Input High Current (Magnitude), $V_{IN} = 2.4\ \text{V}$, $V_{CC} = 3.45\ \text{V}$	μA			40
$I_{IL,LVTTL}$	Input Low Current (Magnitude), $V_{IN} = 0.4\ \text{V}$, $V_{CC} = 3.45\ \text{V}$	μA			-600
I_{CC}	Total Supply Current, $T_A = 25^\circ\text{C}$	mA		150	185

AC Electrical Specifications

V_{CC} = 3.15 V to 3.45 V

Symbol	Parameter	Units	Min.	Typ.	Max.
T _{LOOP_LAT}	Total Loop Latency from FM_NODE[0] to TO_NODE[0]	ns		2.0	
T _{CELL_LAT}	Per Cell Latency from FM_NODE[4] to TO_NODE[0]	ns		0.8	
t _{r,LVTTLin}	Input LVTTL Rise Time Requirement, 0.8 V to 2.0 V	ns		2.0	
t _{f,LVTTLin}	Input LVTTL Fall Time Requirement, 2.0 V to 0.8 V	ns		2.0	
t _{r,LVTTout}	Output TTL Rise Time, 0.8 V to 2.0 V, 10 pF Load	ns		1.7	3.3
t _{f,LVTTout}	Output TTL Fall Time, 2.0 V to 0.8 V, 10 pF Load	ns		1.7	2.4
t _{rs,HS_OUT}	HS_OUT Single-Ended Rise Time, 20%-80%	ps		200	300
t _{fs,HS_OUT}	HS_OUT Single-Ended Fall Time, 20%-80%	ps		200	300
t _{rd,HS_OUT}	HS_OUT Differential Rise Time, 20%-80%	ps		200	300
t _{fd,HS_OUT}	HS_OUT Differential Fall Time, 20%-80%	ps		200	300
V _{IP,HS_IN}	HS_IN Required Peak-to-Peak Differential Input Voltage	mV	200	1200	2000
V _{OP,HS_OUT}	HS_OUT Peak-to-Peak Differential Output Voltage (Z ₀ = 75 Ω, Figure 6)	mV	1100	1400	2000

Guaranteed Operating Rates

V_{CC} = 3.15 V to 3.45 V

FC Serial Clock Rate (MBd)		GE Serial Clock Rate (MBd)	
Min.	Max.	Min.	Max.
1,040	1,080	1,240	1,260

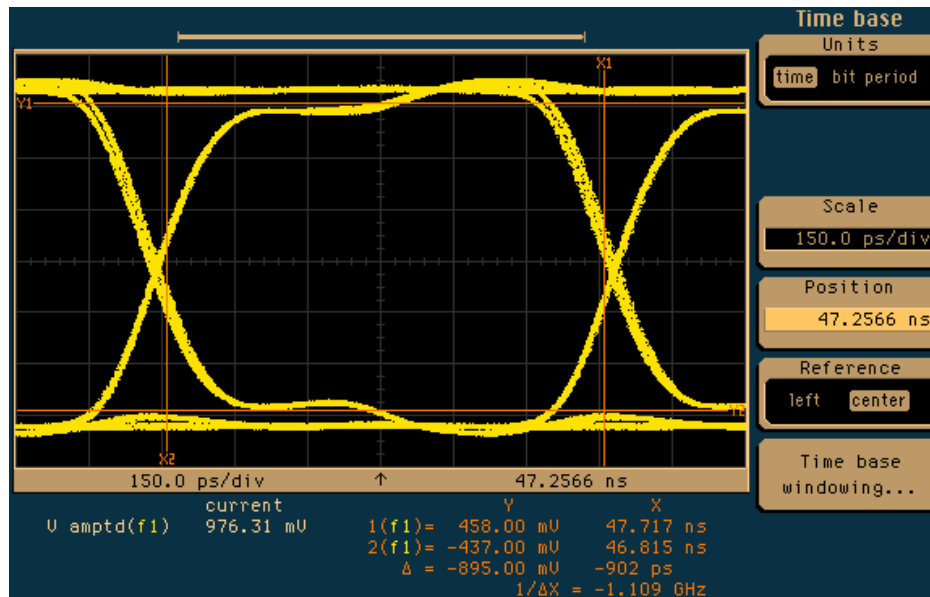

Figure 4. Eye diagram of TO_NODE[1]± high speed differential output (50 Ω termination).

Note: Measurement taken with a 2⁷-1 PRBS input to FM_NODE[1]±.

Simplified I/O Cells

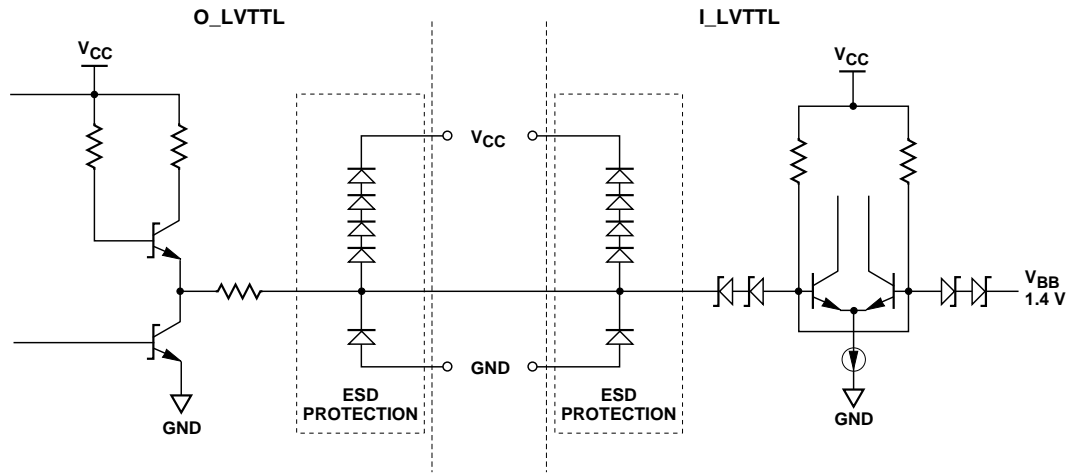
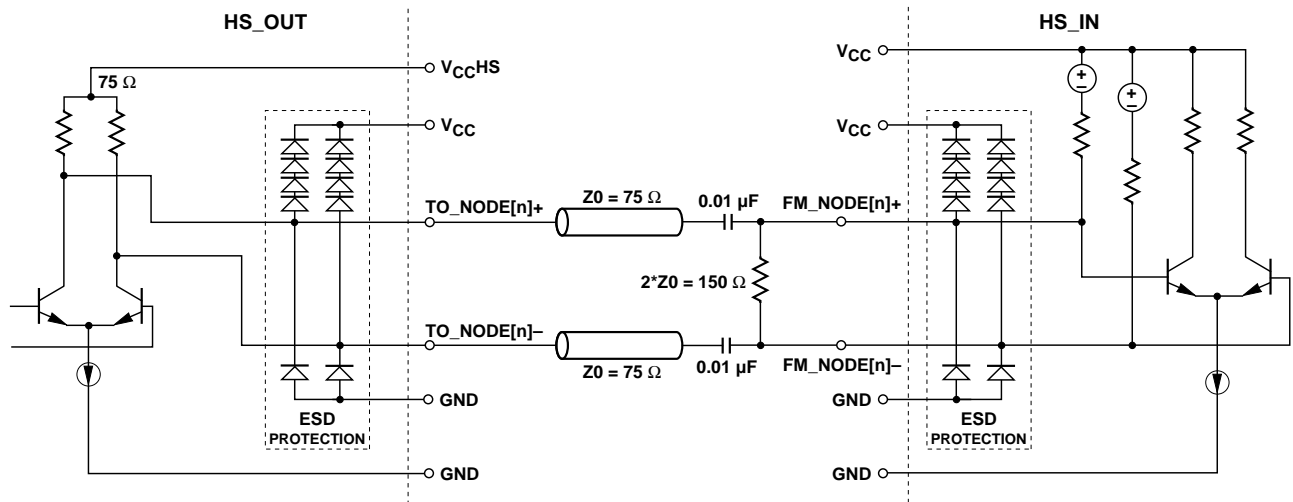

Figure 5. O-LVTTL and I-LVTTL simplified circuit schematic.



NOTE:
FM_NODE[n] INPUTS SHOULD NEVER BE CONNECTED TO GROUND AS PERMANENT DAMAGE TO THE DEVICE MAY RESULT.

Figure 6. HS_OUT and HS_IN simplified circuit schematic.

Package Information

Power Dissipation and Thermal Resistance

$V_{CC} = 3.15 \text{ V to } 3.45 \text{ V}$

Symbol	Parameter	Units	Typ.	Max.
P_D	Power Dissipation	mW	500	640
$\theta_{jc}^{[1]}$	Thermal Resistance, Junction to Case	$^{\circ}\text{C}/\text{W}$	7	

Note:

- Based on independent package testing by Agilent. θ_{ja} for this device is $57^{\circ}\text{C}/\text{W}$. θ_{ja} is measured on a standard 3x3" FR4 PCB in a still air environment. To determine the actual junction temperature in a given application, use the following equation:

$$T_j = T_c + (\theta_{jc} \times P_D), \text{ where } T_c \text{ is the case temperature measured on the top center of the package and } P_D \text{ is the power being dissipated.}$$

Item	Details
Package Material	Plastic
Lead Finish Material	85% Tin, 15% Lead
Lead Finish Thickness	200-800 micro-inches
Lead Skew	0.33 mm max.
Lead Coplanarity (Seating Plane)	0.10 mm max.

Mechanical Dimensions

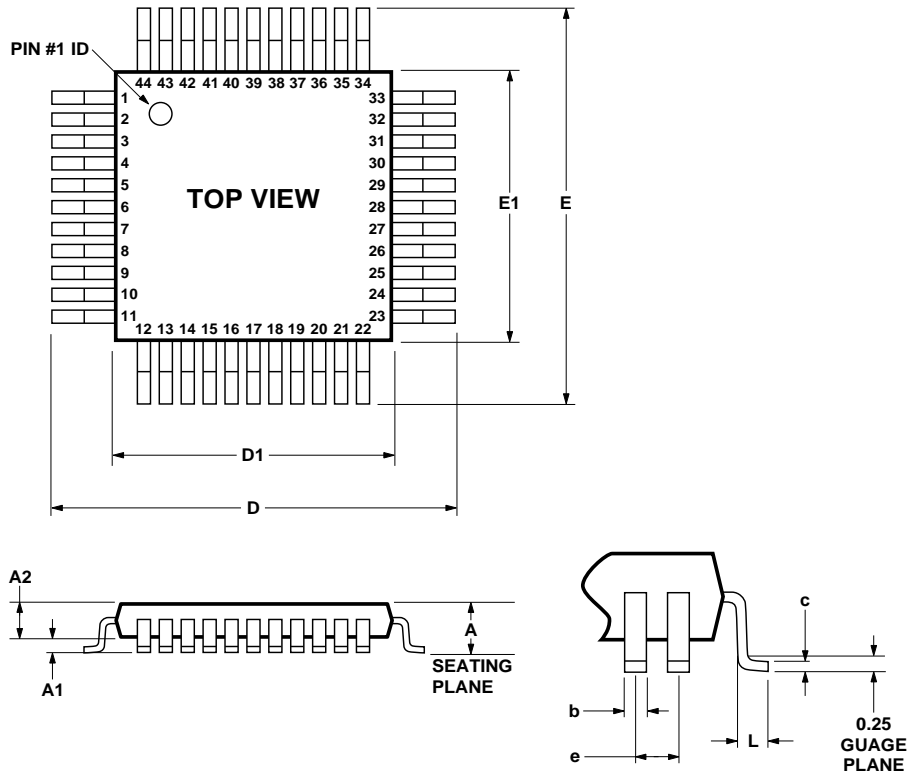

ALL DIMENSIONS ARE IN MILLIMETERS

PART NUMBER	E1/D1	E/D	b	e	L	c	A2	A1	A
HDMP-0450	10.00	13.20	0.35	0.80	0.88	0.23	2.00	0.25	2.45
TOLERANCE	± 0.10	± 0.20	± 0.05	BASIC	$+0.15/-0.10$	MAX.	$+0.10/-0.05$	± 0.25	MAX.

Figure 7. HDMP-0450 package drawing.

Pin Diagram and Recommended Supply Filtering

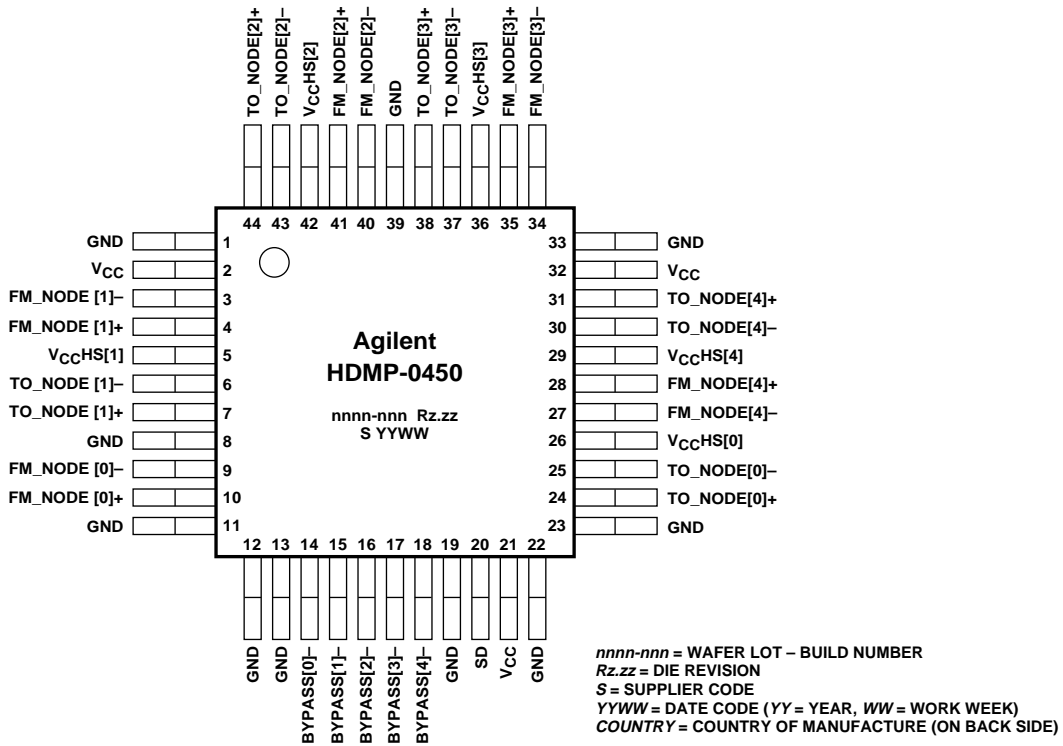

Figure 8. HDMP-0450 package layout and marking, top view.

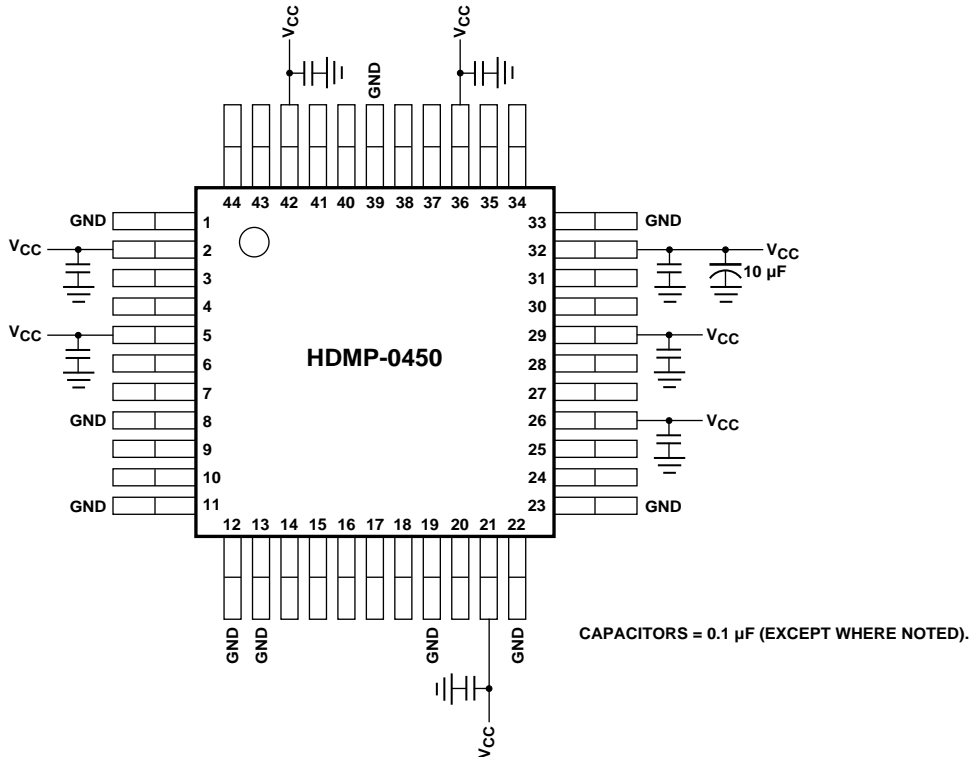

Figure 9. Recommended power supply filtering.

www.agilent.com/semiconductors

For product information and a complete list of distributors, please go to our web site.

For technical assistance call:

Americas/Canada: +1 (800) 235-0312 or
(408) 654-8675

Europe: +49 (0) 6441 92460

China: 10800 650 0017

Hong Kong: (+65) 6271 2451

India, Australia, New Zealand: (+65) 6271 2394

Japan: (+81 3) 3335-8152(Domestic/International), or 0120-61-1280(Domestic Only)

Korea: (+65) 6271 2194

Malaysia, Singapore: (+65) 6271 2054

Taiwan: (+65) 6271 2654

Data subject to change.

Copyright © 2002 Agilent Technologies, Inc.

August 26, 2002

5988-7490EN



Agilent Technologies