



## GENERAL DESCRIPTION

SM5212E is a RF remote control encoder paired with SM5212D. It utilizes CMOS technology. The chip has 12 bits of 2-state address pins that provides 2<sup>12</sup> codes. SM5212E/SM5212D pair is suitable for use on remote controller.

## FEATURES

- \* CMOS technology
- \* Low power consumption
- \* Wide range operating voltage, V<sub>cc</sub> = 2.4~12V
- \* Up to four data bits
- \* High noise immunity

## APPLICATION

- \* Car Security
- \* Garage Door
- \* Ceiling Fan
- \* Home Security/Automatic
- \* Toys
- \* Wireless doorbell

## PIN ASSIGNMENTS (TOP VIEW)

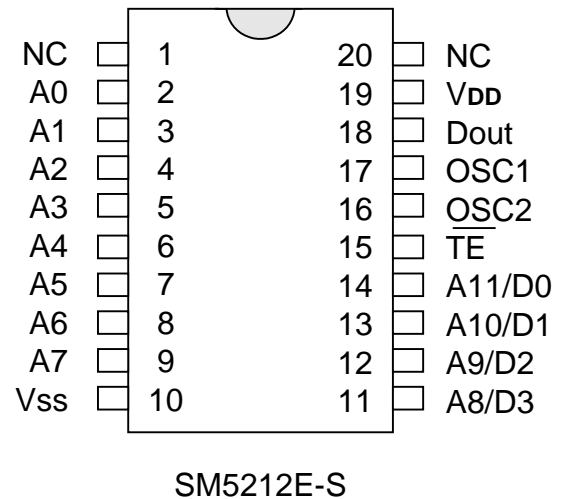
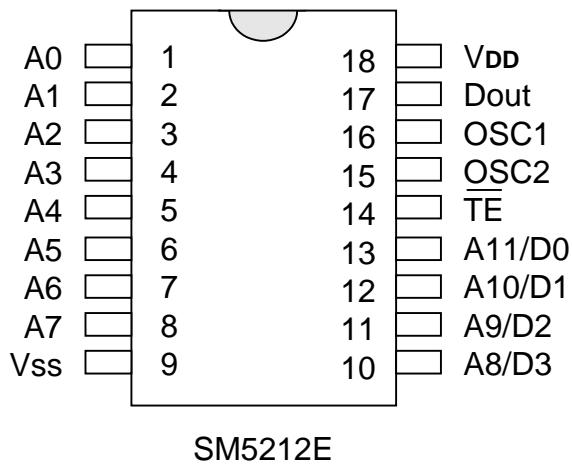



## BLOCK DIAGRAM

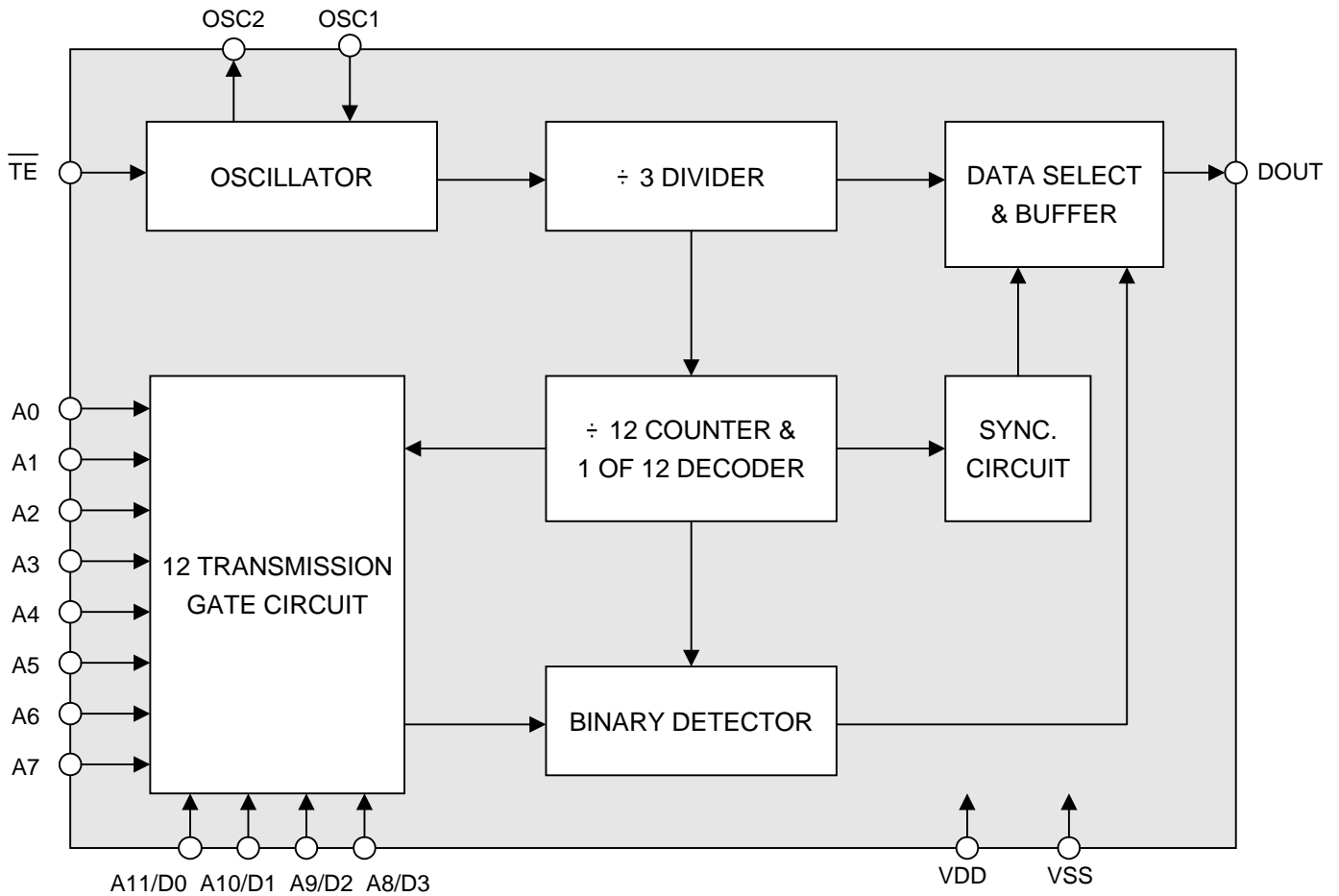



## PIN DESCRIPTION

NO.	PIN NAME	I / O	FUNCTION
1	A0	I	Address input , each pin can be set to "0" , "1".
2	A1	I	
3	A2	I	
4	A3	I	
5	A4	I	
6	A5	I	
7	A6	I	
8	A7	I	
9	Vss	POWER	Negative power supply.
10	A8/D3	I	Address/data input.
11	A9/D2	I	
12	A10/D1	I	
13	A11/D0	I	
14	$\overline{\text{TE}}$	I	Enables transmission.
15	OSC2	O	Resistor connected between these two pins determine the system clock.
16	OSC1	I	
17	Dout	O	Serial output of encoded signals.
18	VDD	POWER	Positive power supply.



## FUNCTION DESCRIPTION

An information word consists of 4 periods as illustrated below.

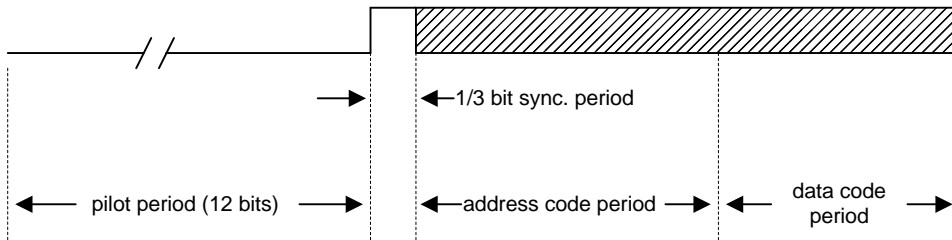

Composition of information

### Address/Data waveform

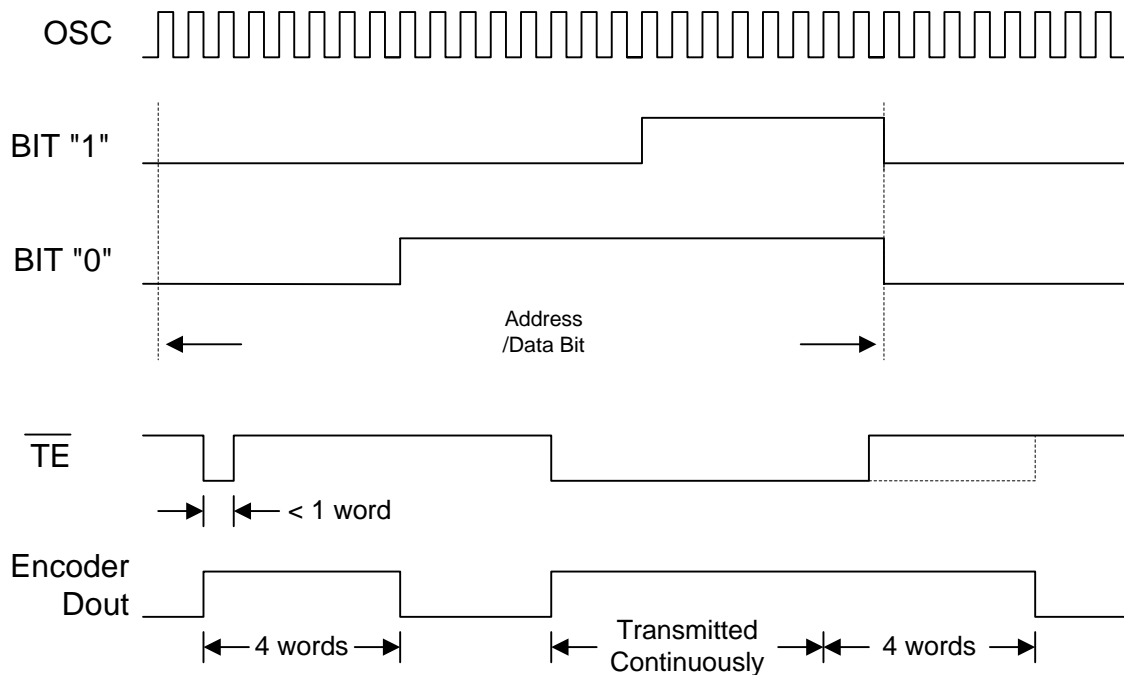

SM5212E begin a 4-word transmission cycle upon receipt of a transmission enable (TE active low). This cycle will repeat itself as long as the transmission enable (TE is held low). Once the transmission enable returns high the encoder output completes its final cycle and then stops as shown below.



## 2. OSC Frequency

SM5212E's oscillator can be constructed by connecting a resistor between OSC1 and OSC2 pin.

Encoder OSC Frequency

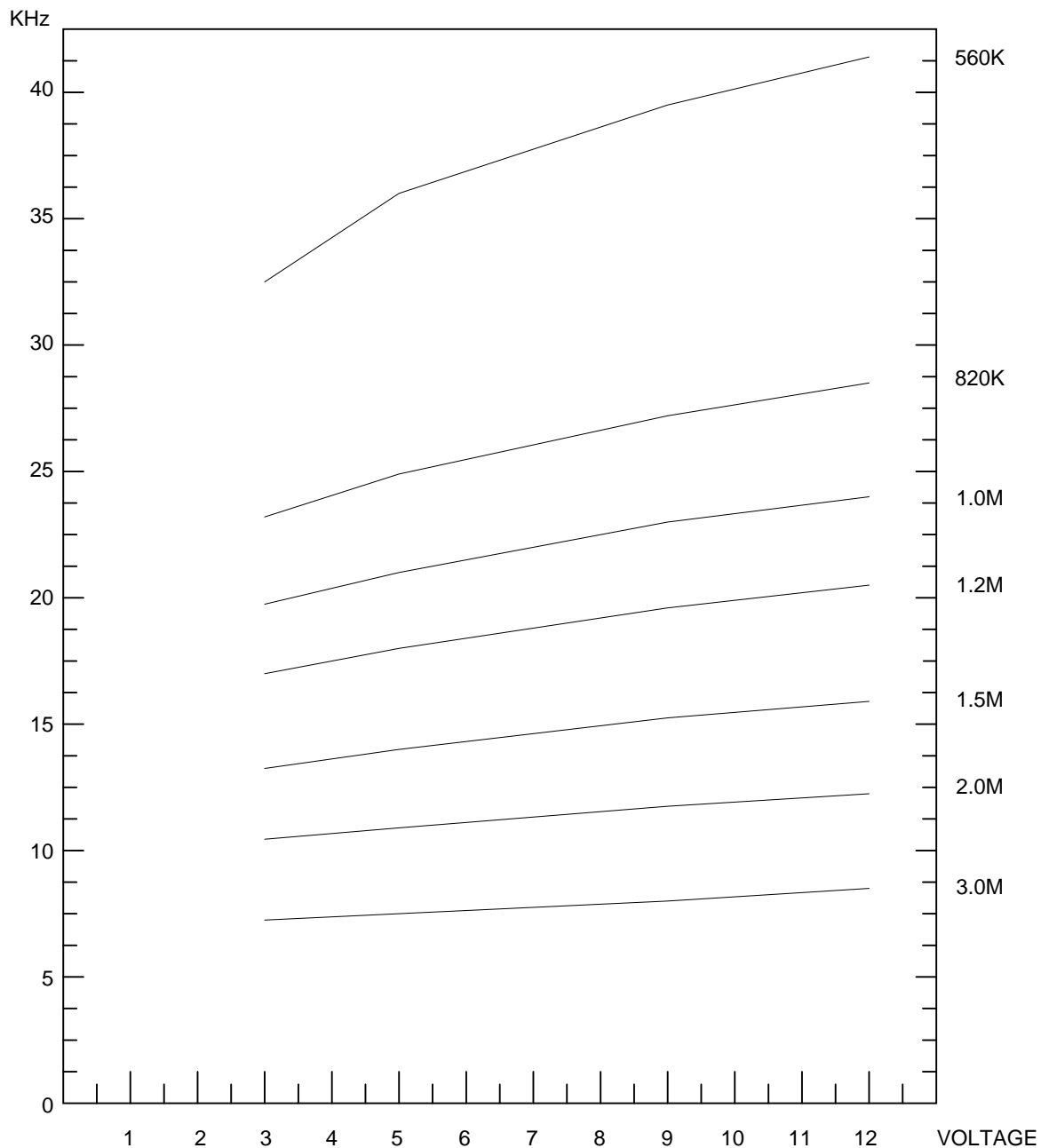

The recommended oscillator frequency is  $F_{OSC D}$  (SM5212D decoder) = 8 - 10  $F_{OSC D}$  (SM5212E encoder)



## ABSOLUTE MAXIMUM RATINGS

Parameter	Symbol	Conditions	Ratings	Unit
Supply Voltage	V <sub>DD</sub> - V <sub>SS</sub>		-0.3~13	V
Input Voltage	V <sub>I</sub> - V <sub>SS</sub>		V <sub>SS</sub> -0.3~V <sub>DD</sub> +0.3	V
Output Voltage	V <sub>O</sub> - V <sub>SS</sub>		V <sub>SS</sub> -0.3~V <sub>DD</sub> +0.3	V
Maximum power dissipation	P <sub>a</sub>	V <sub>DD</sub> - V <sub>SS</sub> = 12V	500	mW
Operating Temperature	T <sub>opr</sub>		-20~70	°C
Storage Temperature	T <sub>stg</sub>		-40~125	°C

## DC ELECTRICAL CHARACTERISTICS

Parameter	Symbol	Test Condition		Limits			Unit
		V <sub>DD</sub>	Conditions	Min.	Typ.	Max.	
Operating Voltage	V <sub>DD</sub>		—	2.4	5	12	V
Operating Current	I <sub>DD</sub>	3V	No load	-	10	20	μA
		12V	F <sub>osc</sub> = 24KHZ	-	150	300	
Standby Current	I <sub>STB</sub>	3V	Oscillator stops	-	0.1	1	μA
		12V		-	-	1	
Output Drive Current	I <sub>DOUT</sub>	5V	V <sub>DH</sub> = 0.9V <sub>DD</sub> (SOURCE)	-1	- 1.6	-	mA
			V <sub>OL</sub> = 0.1V <sub>DD</sub> (Sink)	1	1.6	-	
"H" Input Voltage	V <sub>IH</sub>	—	—	0.8V <sub>DD</sub>		V <sub>DD</sub>	V
"L" Input Voltage	V <sub>IL</sub>	—	—	0		0.2V <sub>DD</sub>	V
Oscillator Frequency	F <sub>OSC</sub>	5V	R <sub>OSC</sub> = 1M	—	24	—	kHz
$\overline{TE}$ Pull-High Resistance	R $\overline{TE}$	5V	V $\overline{TE}$ = 0V	—	400	—	K

(T<sub>a</sub>=25°C)



## APPLICATION CIRCUIT

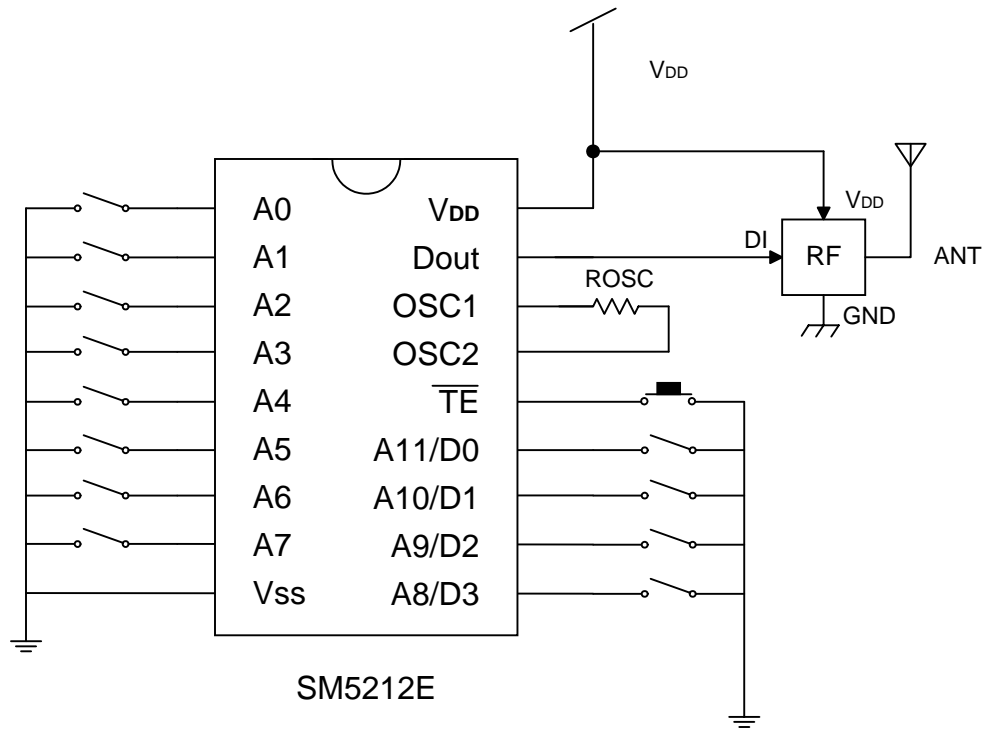



**ORDERING INFORMATION**

Part NO.	Package
SM5212E	18Pin DIP

Part NO.	Package
SM5212E-S	20Pin SOP

