

High-Voltage, High-Current Darlington Transistor Arrays

GENERAL DESCRIPTION

The XR-2001/2002/2003/2004 are high-voltage, high-current Darlington transistor arrays consisting of seven silicon NPN Darlington pairs on a common monolithic substrate. All units feature open collector outputs and integral protection diodes for driving inductive loads. Peak inrush currents of up to 600 mA are allowed, which makes the arrays ideal for driving tungsten filament lamps. The outputs may be paralleled to achieve high load current capability although each driver has a maximum continuous collector current rating of 500 mA. The arrays are directly price competitive with discrete transistor alternatives.

FEATURES

- Peak Inrush Current Capability of 600 mA.
- Internal Protection Diodes for Driving Inductive Loads
- Excellent Noise Immunity
- Direct Compatibility with Most Logic Families
- Opposing Pin Configuration Eases Circuit Board Layout

APPLICATIONS

- Relay Drivers
- High Current Logic Drivers
- Solenoid Driver

ABSOLUTE MAXIMUM RATINGS $T_A = 25^\circ\text{C}$

Output Voltage, V_{CE}	50V
Input Voltage, V_{IN}	30V
Continuous Collector Current, I_C (Each Driver)	500mA
Continuous Base Current, I_B (Each Driver)	25mA
Power Dissipation, P_D (Each Driver)	1.0W
(Total Package)	See graph
Derate Above 25°C	16 mW/ $^\circ\text{C}$
Storage Temperature Range	-55°C to $+150^\circ\text{C}$

FUNCTIONAL BLOCK DIAGRAM

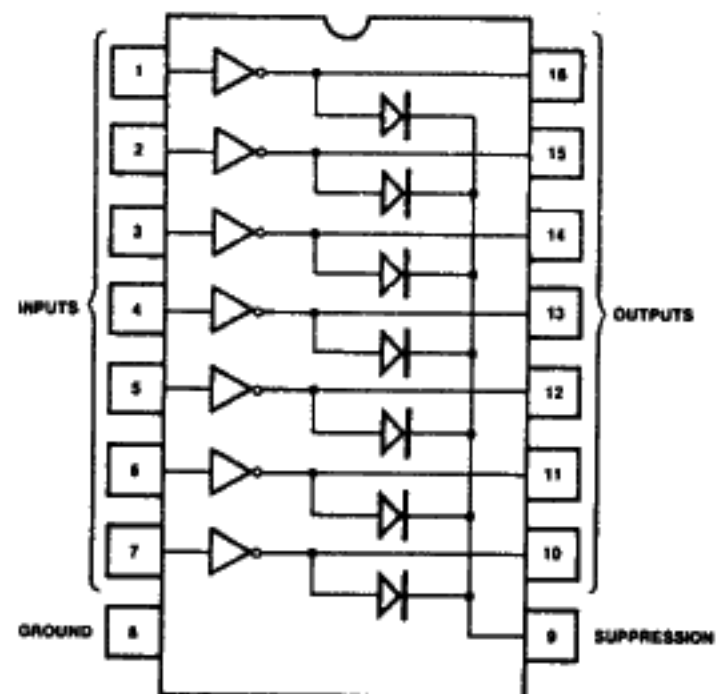

ORDERING INFORMATION

Part Number	Package	Operating Temperature
XR-2001CN	Ceramic	0°C to $+70^\circ\text{C}$
XR-2002CN	Ceramic	0°C to $+70^\circ\text{C}$
XR-2003CN	Ceramic	0°C to $+70^\circ\text{C}$
XR-2004CN	Ceramic	0°C to $+70^\circ\text{C}$

SYSTEM DESCRIPTION

The XR-2001 interfaces with bipolar digital logic (with external current limiting), or with CMOS or PMOS directly.

The XR-2002 was specifically designed to interface with 14V to 25V PMOS devices.

The XR-2003 permits operation directly with CMOS or TTL operating at a supply voltage of 5 volts. Interface requirements beyond the scope of standard logic buffers are easily handled by the XR-2003.

The XR-2004 requires less input current than the XR-2003 and the input voltage is less than that required by the XR-2002. The XR-2004 operates directly from PMOS or CMOS outputs using supply voltages of 6 to 15 volts.

XR-2001/2/3/4

ELECTRICAL CHARACTERISTICS

Test Conditions: T_A 25°C, unless otherwise specified.

SYMBOL	PARAMETERS	LIMITS			UNITS	CONDITIONS
		MIN	TYP	MAX		
I_{CEX}	Output Leakage Current XR-2002 XR-2004			100	μA	$V_{CE} = 50 V, T_A = 70^\circ C$
				500	μA	$V_{CE} = 50 V, T_A = 70^\circ C, V_{IN} = 6V$
				500	μA	$V_{CE} = 50 V, T_A = 70^\circ C, V_{IN} = 1V$
V_{CE}	Collector-Emitter Saturation Voltage		1.25	1.6	V	$I_C = 350mA, I_B = 500\mu A$
			1.1	1.3	V	$I_C = 200mA, I_B = 350\mu A$
			0.9	1.1	V	$I_C = 100mA, I_B = 250\mu A$
I_{IN}	Input Current (on) XR-2002 XR-2003 XR-2004		0.85	1.25	mA	$V_{IN} = 17V$
			0.93	1.35	mA	$V_{IN} = 3.85V$
			0.35	0.5	mA	$V_{IN} = 5V$
			1.0	1.45	mA	$V_{IN} = 12V$
I_{IN}	Input Current (off)	50	65		μA	$I_C = 500\mu A, T_A = 70^\circ C$
V_{IN}	Input Voltage XR-2002 XR-2003 XR-2004			13	V	$V_{CE} = 2 V, I_C = 300mA$
				2.4	V	$V_{CE} = 2 V, I_C = 200mA$
				2.7	V	$V_{CE} = 2 V, I_C = 250mA$
				3.0	V	$V_{CE} = 2 V, I_C = 300mA$
				5.0	V	$V_{CE} = 2 V, I_C = 125mA$
				6.0	V	$V_{CE} = 2 V, I_C = 200mA$
				7.0	V	$V_{CE} = 2 V, I_C = 275mA$
				8.0	V	$V_{CE} = 2 V, I_C = 350mA$
h_{FE}	D-C Forward Current Transfer Ratio XR-2001	1000				$V_{CE} = 2 V, I_C = 350mA$
C_{IN}	Input Capacitance		15	30	pF	
I_R	Clamp Diode Leakage Current			50	μA	$V_R = 50V$
V_F	Clamp Diode Forward Voltage		1.7	2.0	V	$I_F = 350mA$
t_{PLH}	Turn-On Delay		0.25	1.0	μS	0.5 E_{IN} to 0.5 E_{OUT}
t_{PHL}	Turn-Off Delay		0.25	1.0	μS	0.5 E_{IN} to 0.5 E_{OUT}

SCHEMATIC DIAGRAMS (One of 7 Identical Drivers is shown for each device.)

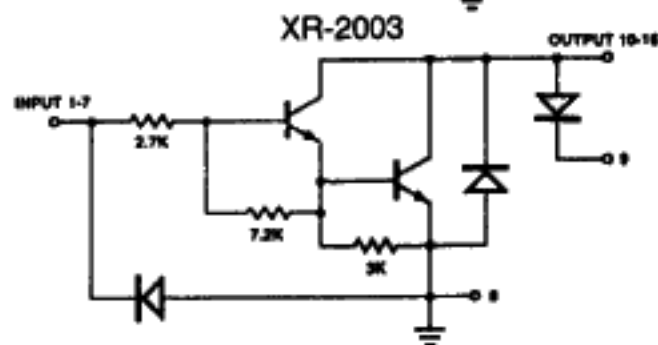
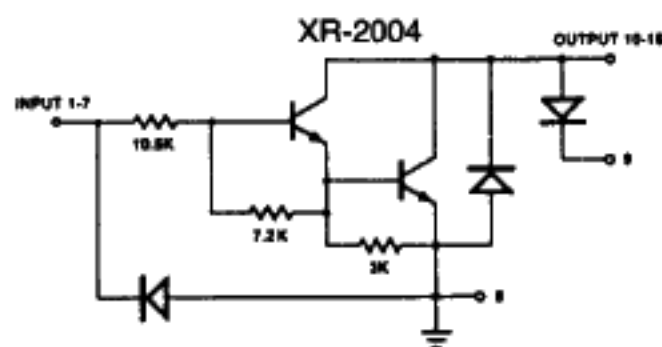
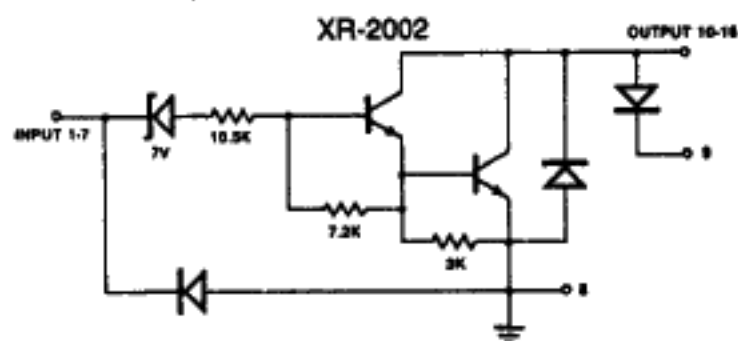
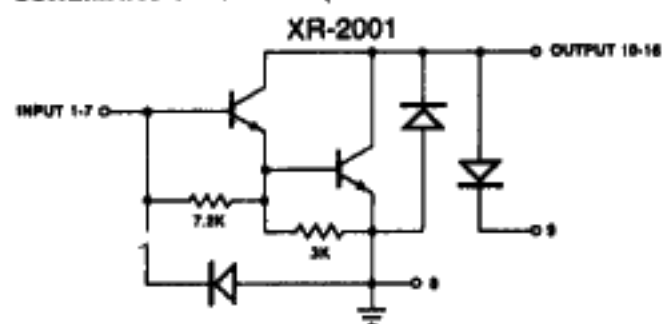

XR-2001/2/3/4

CHARACTERISTIC CURVES

(a) XR-2002

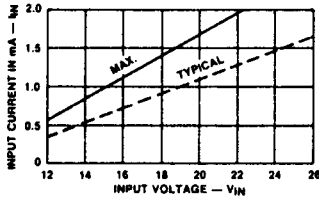

(b) XR-2004

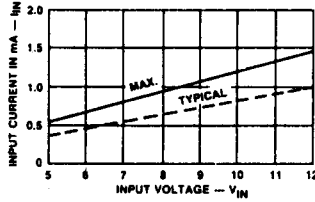

(c) XR-2003

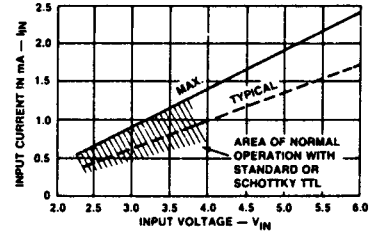

Figure 1. Input Current as a Function of Input Voltages

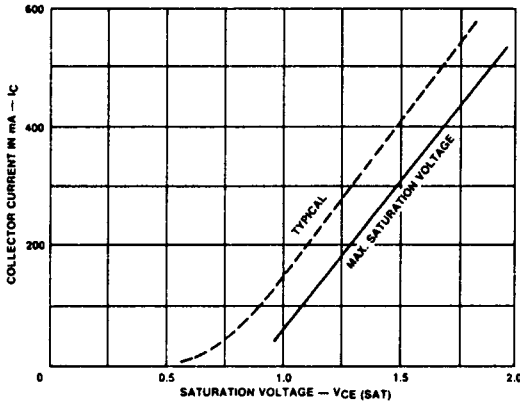

Figure 2. Collector Current as a Function of Saturation Voltage.

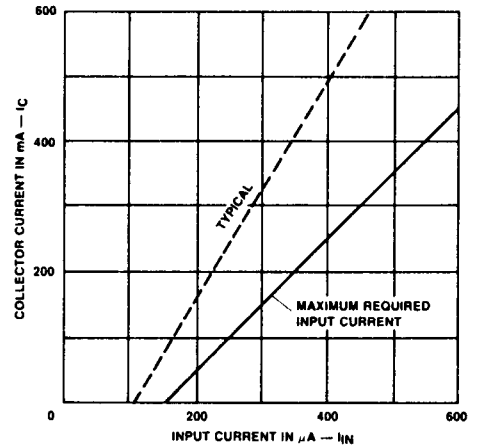

Figure 3. Collector Current as a Function of Input Current

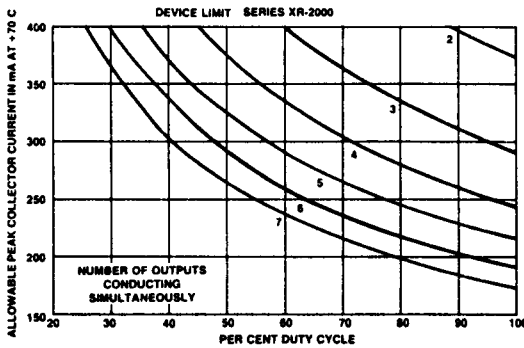

Figure 4. Peak Collector Current as a Function of Duty Cycle and Number of Outputs

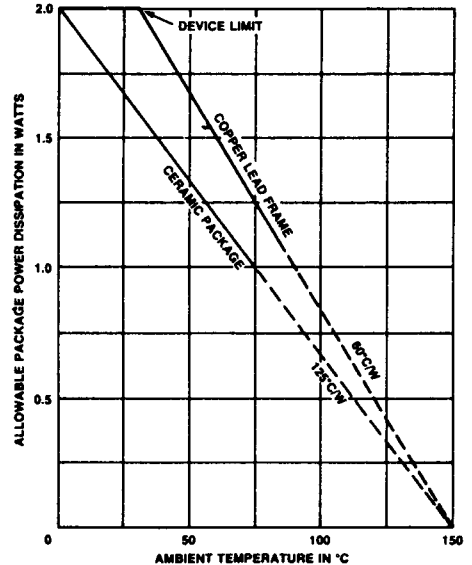

Figure 5. Allowable Average Power Dissipation as a Function of Ambient Temperature

XR-2001/2/3/4

TYPICAL APPLICATIONS

XR-2002

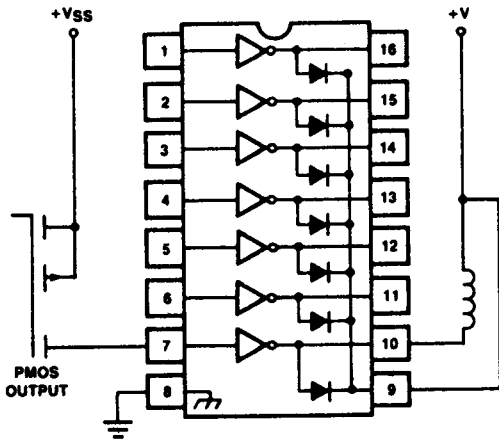

Figure 6. PMOS to Load

XR-2003

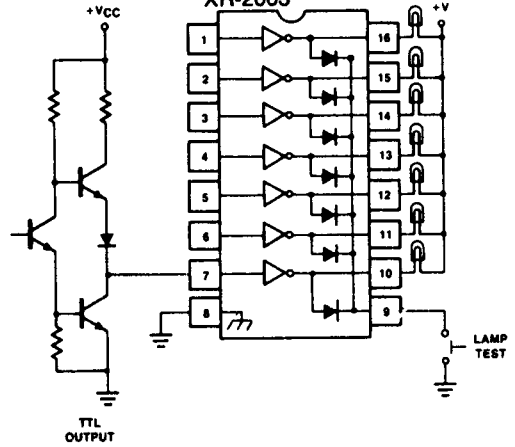

Figure 7. TTL to Load

XR-2004

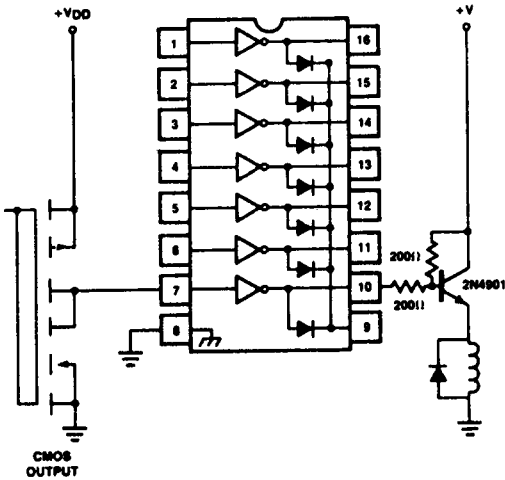

Figure 8. Buffer for Higher Current Loads

XR-2003

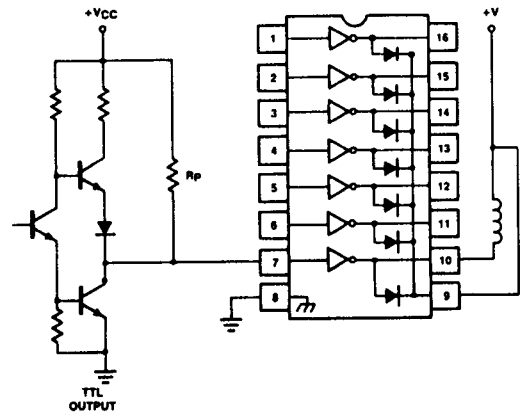

Figure 9. Use of Pull-up Resistors to Increase Drive Current

7

3422618 EXAR CORP

EXAR

91D 04225

D7-75-45-05

XR-1488/1489A

Quad Line Driver/Receiver

GENERAL DESCRIPTION

The XR-1488 is a monolithic quad line driver designed to interface data terminal equipment with data communications equipment in conformance with the specifications of EIA Standard No. RS232C. This extremely versatile integrated circuit can be used to perform a wide range of applications. Features such as output current limiting, independent positive and negative power supply driving elements, and compatibility with all DTL and TTL logic families greatly enhance the versatility of the circuit.

The XR-1489A is a monolithic quad line receiver designed to interface data terminal equipment with data communications equipment. The XR-1489A quad receiver along with its companion circuit, the XR-1488 quad driver, provide a complete interface system between DTL or TTL logic levels and the RS232C defined voltage and impedance levels.

ABSOLUTE MAXIMUM RATINGS

Power Supply		
XR-1488		± 15 Vdc
XR-1489A		+ 10 Vdc
Power Dissipation		
Ceramic Package		1000 mW
Derate above +25°C		6.7 mW/°C
Plastic Package		650 mW/°C
Derate above +25°C		5 mW/°C

ORDERING INFORMATION

Part Number	Package	Operating Temperature
XR-1488N	Ceramic	0°C to +70°C
XR-1488P	Plastic	0°C to +70°C
XR-1489AN	Ceramic	0°C to +70°C
XR-1489AP	Plastic	0°C to +70°C

FUNCTIONAL BLOCK DIAGRAMS

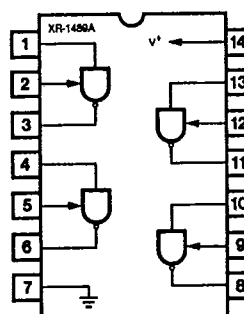
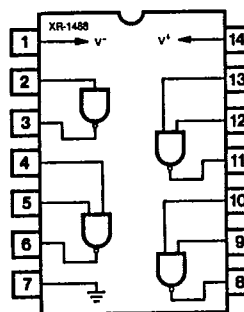

SYSTEM DESCRIPTION

The XR-1488 and XR-1489A are a matched set of quad line drivers and line receivers designed for interfacing between TTL/DTL and RS232C data communication lines.

The XR-1488 contains four independent split supply line drivers, each with a ± 10 mA current limited output. For RS232C applications, the slew rate can be reduced to the 30 V/ μ S limit by shunting the output to ground with a 410 pF capacitor. The XR-1489A contains four independent line receivers, designed for interfacing RS232C to TTL/DTL. Each receiver features independently programmable switching thresholds with hysteresis, and input protection to ± 30 V. The output can typically source 3 mA and sink 20 mA.

3422618 EXAR CORP
XR-494

91D 04470 D

T-58-11-31

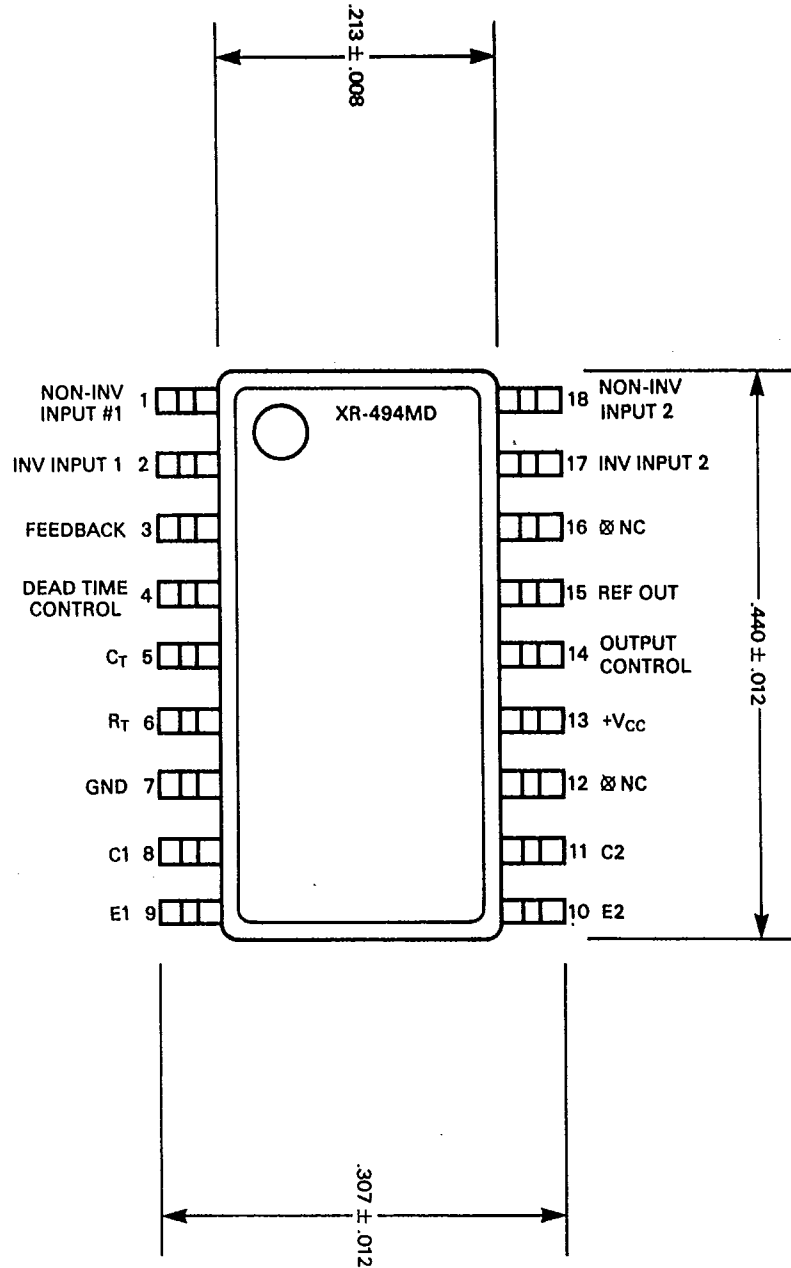

3422618 EXAR CORP

91D 04475 DT-58-11-03

XR-1468/1568

Dual-Polarity Tracking Voltage Regulator

GENERAL DESCRIPTION

The XR-1468/1568 is a dual polarity tracking voltage regulator, internally trimmed for symmetrical positive and negative 15V outputs. Current output capability is 100 mA, and may be increased by adding external pass transistors. The device is intended for local "on-card" regulation, which eliminates the distribution problems associated with single point regulation.

The XR-1468CN and XR-1568N are guaranteed over the 0°C to 70°C commercial temperature range. The XR-1568M is rated over the full military temperature range of -55°C to +125°C.

FEATURES

- Internally Set for $\pm 15V$ Outputs
- ± 100 mA Peak Output Current
- Output Voltages Balanced Within 1% (XR-1568)
- 0.06% Line and Load Regulation
- Low Stand-By Current
- Output Externally Adjustable from ± 8 to ± 20 Volts
- Externally Adjustable Current Limiting
- Remote Sensing

APPLICATIONS

- Main Regulation in Small Instruments
- On-Card Regulation in Analog and Digital Systems
- Point-of-Load Precision Regulation

ABSOLUTE MAXIMUM RATINGS

Power Supply	± 30 Volts
Minimum Short-Circuit Resistance	4.0 Ohms
Load Current, Peak	± 100 mA
Power Dissipation	
Ceramic (N) Package	1.0 Watt
Derate Above +25°C	6.7 mW/°C
Operating Temperature	
XR-1568M	-55°C to +125°C
XR-1568/XR-1468C	0°C to +70°C
Storage Temperature	-65°C to +150°C

FUNCTIONAL BLOCK DIAGRAM

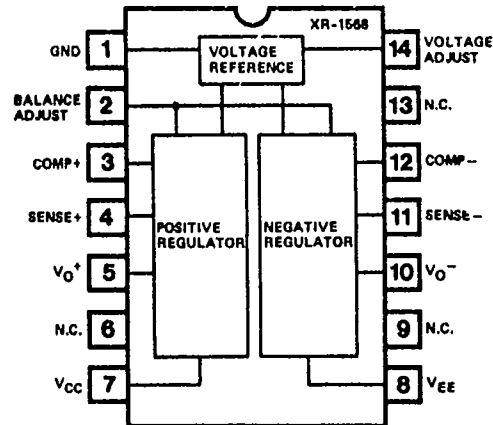

5

ORDERING INFORMATION

Part Number	Temperature	Output Offset	Package
XR-1568M	-55°C to +125°C	± 150 mV max	Ceramic
XR-1568N	0°C to +70°C	± 150 mV max	Ceramic
XR-1468CN	0°C to +70°C	± 300 mV max	Ceramic

SYSTEM DESCRIPTION

The XR-1468/1568 is a dual polarity tracking voltage regulator combining two separate regulators with a common reference element in a single monolithic circuit, thus providing a very close balance between the positive and negative output voltages. Outputs are internally set to ± 15 Volts but can be externally adjusted between ± 8.0 to ± 20 Volts with a single control. The circuit features ± 100 mA output current, with externally adjustable current limiting, and provision for remote voltage sensing.