

VRS550 - 8kB Flash, 256B RAM, 25MHz, 8-Bit MCU
VRS560 - 16kB Flash, 256B RAM, 25MHz, 8-Bit MCU
Datasheet Rev 1.1



Overview

The VRS550 and the VRS560 are both low cost 8-bit microcontrollers based on the standard 80C51 microcontroller family architecture. They are pin-to-pin compatible and drop-in replacements for most 8051 MCUs. The VRS550 and VRS560 have 8kB and 16kB, respectively of Flash memory. Both devices have 256 bytes of RAM memory.

The hardware features of these devices and their re-programmability make them suitable for a wide range of applications.

These VRS550 and VRS560 are both available in PLCC-44 and QFP-44 packages in the Industrial temperature range. The Flash memory can be programmed using programmers available from Goal Semiconductor or other 3rd party commercial programmers.

Feature Set

- General 80C51/80C52 pin compatible
- 12 clock periods per machine cycle
- 8k / 16k on-chip Flash memory
- 256 Bytes on-chip data RAM
- 32 I/O lines on four 8-bit ports
- Full duplex serial port (UART)
- 3, 16-bit Timers/Counters
- Watch Dog Timer
- 8-bit Unsigned Division / Multiply
- BCD arithmetic
- Direct and Indirect Addressing
- Two levels of interrupt priority and nested interrupts
- Power saving modes
- Code protection function
- Operates at a clock frequency of up to 25MHz
- Low EMI (inhibit ALE)
- Programming voltage: 12V
- Industrial Temperature range (-40°C to +85°C)
- 5V and 3V versions available (see Ordering information.)

FIGURE 1: VRS550 / VRS560 FUNCTIONAL DIAGRAM

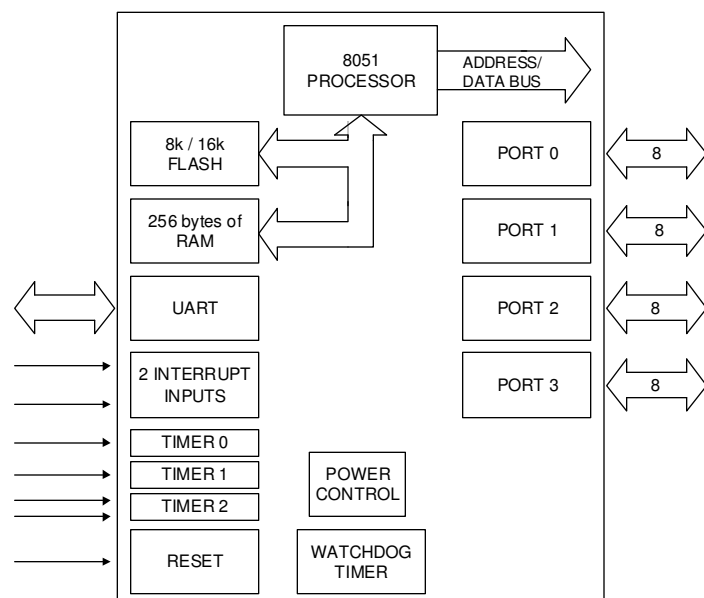
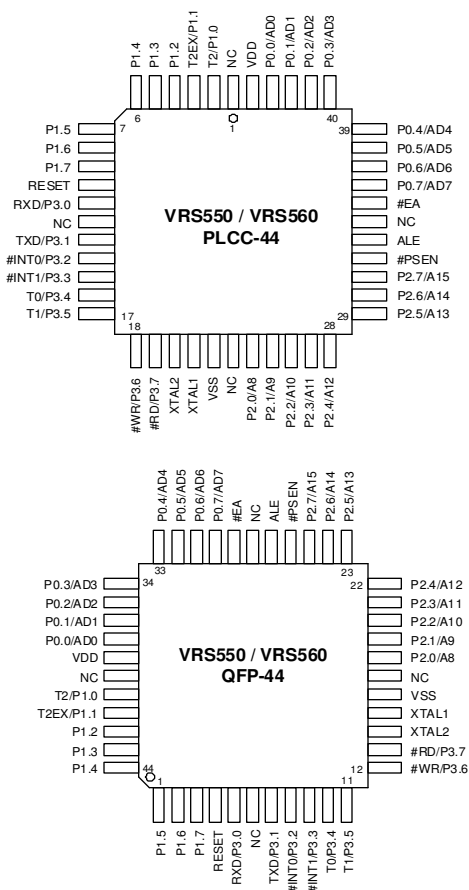

FIGURE 2: VRS550 / VRS560 PLCC AND QFP PINOUT DIAGRAMS



Pin Descriptions for QFP-44

TABLE 1: PIN DESCRIPTIONS FOR QFP-44/

| QFP - 44 | Name | I/O | Function |
|----------|-------|-----|-----------------------------------|
| 1 | P1.5 | I/O | Bit 5 of Port 1 |
| 2 | P1.6 | I/O | Bit 6 of Port 1 |
| 3 | P1.7 | I/O | Bit 7 of Port 1 |
| 4 | RES | I | Reset |
| 5 | RXD | I | Receive Data |
| | P3.0 | I/O | Bit 0 of Port 3 |
| 6 | NC | - | No Connect |
| 7 | TXD | O | Transmit Data & |
| | P3.1 | I/O | Bit 1 of Port 3 |
| 8 | #INT0 | I | External Interrupt 0 |
| | P3.2 | I/O | Bit 2 of Port 3 |
| 9 | #INT1 | I | External Interrupt 1 |
| | P3.3 | I/O | Bit 3 of Port 3 |
| 10 | T0 | I | Timer 0 |
| | P3.4 | I/O | Bit 4 of Port 3 |
| 11 | T1 | I | Timer 1 & 3 |
| | P3.5 | I/O | Bit 5 of Port 3 |
| 12 | #WR | O | Ext. Memory Write |
| | P3.6 | I/O | Bit 6 of Port 3 |
| 13 | #RD | O | Ext. Memory Read |
| | P3.7 | I/O | Bit 7 of Port 3 |
| 14 | XTAL2 | O | Oscillator/Crystal Output |
| 15 | XTAL1 | I | Oscillator/Crystal In |
| 16 | VSS | - | Ground |
| 17 | NC | - | No Connect |
| 18 | P2.0 | I/O | Bit 0 of Port 2 |
| | A8 | O | Bit 8 of External Memory Address |
| 19 | P2.1 | I/O | Bit 1 of Port 2 |
| | A9 | O | Bit 9 of External Memory Address |
| 20 | P2.2 | I/O | Bit 2 of Port 2 |
| | A10 | O | Bit 10 of External Memory Address |
| 21 | P2.3 | I/O | Bit 3 of Port 2 & |
| | A11 | O | Bit 11 of External Memory Address |
| 22 | P2.4 | I/O | Bit 4 of Port 2 |
| | A12 | O | Bit 12 of External Memory Address |
| 23 | P2.5 | I/O | Bit 5 of Port 2 |
| | A13 | O | Bit 13 of External Memory Address |

| QFP - 44 | Name | I/O | Function |
|----------|-------|-----|---------------------------------------|
| 24 | P2.6 | I/O | Bit 6 of Port 2 |
| | A14 | O | Bit 14 of External Memory Address |
| 25 | P2.7 | I/O | Bit 7 of Port 2 |
| | A15 | O | Bit 15 of External Memory Address |
| 26 | #PSEN | O | Program Store Enable |
| 27 | ALE | O | Address Latch Enable |
| 28 | NC | - | No Connect |
| 29 | #EA | I | External Access |
| 30 | P0.7 | I/O | Bit 7 Of Port 0 |
| | AD7 | I/O | Data/Address Bit 7 of External Memory |
| 31 | P0.6 | I/O | Bit 6 of Port 0 |
| | AD6 | I/O | Data/Address Bit 6 of External Memory |
| 32 | P0.5 | I/O | Bit 5 of Port 0 |
| | AD5 | I/O | Data/Address Bit 5 of External Memory |
| 33 | P0.4 | I/O | Bit 4 of Port 0 |
| | AD4 | I/O | Data/Address Bit 4 of External Memory |
| 34 | P0.3 | I/O | Bit 3 Of Port 0 |
| | AD3 | I/O | Data/Address Bit 3 of External Memory |
| 35 | P0.2 | I/O | Bit 2 of Port 0 |
| | AD2 | I/O | Data/Address Bit 2 of External Memory |
| 36 | P0.1 | I/O | Bit 1 of Port 0 & Data |
| | AD1 | I/O | Address Bit 1 of External Memory |
| 37 | P0.0 | I/O | Bit 0 Of Port 0 & Data |
| | AD0 | I/O | Address Bit 0 of External Memory |
| 38 | VDD | - | VCC |
| 39 | NC | - | No Connect |
| 40 | T2 | I | Timer 2 Clock Out |
| | P1.0 | I/O | Bit 0 of Port 1 |
| 41 | T2EX | I | Timer 2 Control |
| | P1.1 | I/O | Bit 1 of Port 1 |
| 42 | P1.2 | I/O | Bit 2 of Port 1 |
| 43 | P1.3 | I/O | Bit 3 of Port 1 |
| 44 | P1.4 | I/O | Bit 4 of Port 1 |

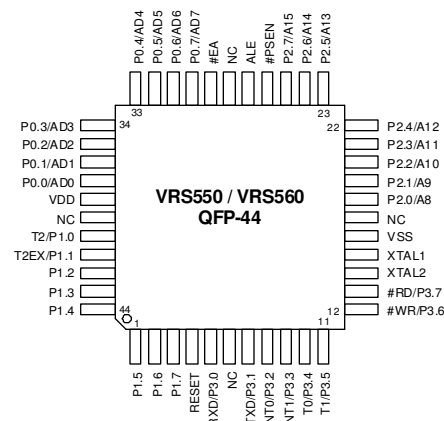

Pin Descriptions for PLCC-44

TABLE 2: PIN DESCRIPTIONS FOR PLCC-44

| PLCC - 44 | Name | I/O | Function |
|-----------|-------|-----|---------------------------|
| 1 | NC | - | No Connect |
| 2 | T2 | I | Timer 2 Clock Out |
| | P1.0 | I/O | Bit 0 of Port 1 |
| 3 | T2EX | I | Timer 2 Control |
| | P1.1 | I/O | Bit 1 of Port 1 |
| 4 | P1.2 | I/O | Bit 2 of Port 1 |
| 5 | P1.3 | I/O | Bit 3 of Port 1 |
| 6 | P1.4 | I/O | Bit 4 of Port 1 |
| 7 | P1.5 | I/O | Bit 5 of Port 1 |
| 8 | P1.6 | I/O | Bit 6 of Port 1 |
| 9 | P1.7 | I/O | Bit 7 of Port 1 |
| 10 | RES | I | Reset |
| 11 | RXD | I | Receive Data |
| | P3.0 | I/O | Bit 0 of Port 3 |
| 12 | NC | - | No Connect |
| 13 | TXD | O | Transmit Data & |
| | P3.1 | I/O | Bit 1 of Port 3 |
| 14 | #INT0 | I | External Interrupt 0 |
| | P3.2 | I/O | Bit 2 of Port 3 |
| 15 | #INT1 | I | External Interrupt 1 |
| | P3.3 | I/O | Bit 3 of Port 3 |
| 16 | T0 | I | Timer 0 |
| | P3.4 | I/O | Bit 4 of Port 3 |
| 17 | T1 | I | Timer 1 & 3 |
| | P3.5 | I/O | Bit 5 of Port |
| 18 | #WR | O | Ext. Memory Write |
| | P3.6 | I/O | Bit 6 of Port 3 |
| 19 | #RD | O | Ext. Memory Read |
| | P3.7 | I/O | Bit 7 of Port 3 |
| 20 | XTAL2 | O | Oscillator/Crystal Output |
| 21 | XTAL1 | I | Oscillator/Crystal In |
| 22 | VSS | - | Ground |
| 23 | NC | - | No Connect |

| PLCC - 44 | Name | I/O | Function |
|-----------|-------|-----|---------------------------------------|
| 24 | P2.0 | I/O | Bit 0 of Port 2 |
| | A8 | O | Bit 8 of External Memory Address |
| 25 | P2.1 | I/O | Bit 1 of Port 2 |
| | A9 | O | Bit 9 of External Memory Address |
| 26 | P2.2 | I/O | Bit 2 of Port 2 |
| | A10 | O | Bit 10 of External Memory Address |
| 27 | P2.3 | I/O | Bit 3 of Port 2 & |
| | A11 | O | Bit 11 of External Memory Address |
| 28 | P2.4 | I/O | Bit 4 of Port 2 |
| | A12 | O | Bit 12 of External Memory Address |
| 29 | P2.5 | I/O | Bit 5 of Port 2 |
| | A13 | O | Bit 13 of External Memory Address |
| 30 | P2.6 | I/O | Bit 6 of Port 2 |
| | A14 | O | Bit 14 of External Memory Address |
| 31 | P2.7 | I/O | Bit 7 of Port 2 |
| | A15 | O | Bit 15 of External Memory Address |
| 32 | #PSEN | O | Program Store Enable |
| 33 | ALE | O | Address Latch Enable |
| 34 | NC | - | No Connect |
| 35 | #EA | I | External Access |
| | P0.7 | I/O | Bit 7 Of Port 0 |
| 36 | AD7 | I/O | Data/Address Bit 7 of External Memory |
| | P0.6 | I/O | Bit 6 of Port 0 |
| 37 | AD6 | I/O | Data/Address Bit 6 of External Memory |
| | P0.5 | I/O | Bit 5 of Port 0 |
| 38 | AD5 | I/O | Data/Address Bit 5 of External Memory |
| | P0.4 | I/O | Bit 4 of Port 0 |
| 39 | AD4 | I/O | Data/Address Bit 4 of External Memory |
| | P0.3 | I/O | Bit 3 Of Port 0 |
| 40 | AD3 | I/O | Data/Address Bit 3 of External Memory |
| | P0.2 | I/O | Bit 2 of Port 0 |
| 41 | AD2 | I/O | Data/Address Bit 2 of External Memory |
| | P0.1 | I/O | Bit 1 of Port 0 & Data |
| 42 | AD1 | I/O | Address Bit 1 of External Memory |
| | P0.0 | I/O | Bit 0 Of Port 0 & Data |
| 43 | AD0 | I/O | Address Bit 0 of External Memory |
| | VDD | - | VCC |

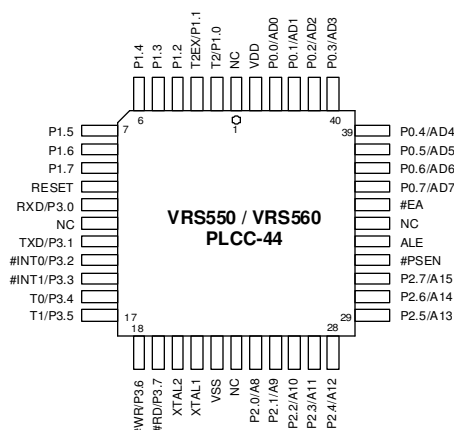

Instruction Set

The following two tables describe the instruction set of the VRS550 and VRS560 devices. The instructions are binary code compatible and perform the same functions as the industry standard 8051 ones.

TABLE 3: LEGEND FOR INSTRUCTION SET TABLE

| Symbol | Function |
|----------|--|
| A | Accumulator |
| Rn | Register R0-R7 |
| Direct | Internal register address |
| @Ri | Internal register pointed to by R0 or R1 (except MOVX) |
| rel | Two's complement offset byte |
| bit | Direct bit address |
| #data | 8-bit constant |
| #data 16 | 16-bit constant |
| addr 16 | 16-bit destination address |
| addr 11 | 11-bit destination address |

TABLE 4: VRS550/VRS560 INSTRUCTION SET

| Mnemonic | Description | Size (bytes) | Instr. Cycles |
|--------------------------------|---|--------------|---------------|
| Arithmetic instructions | | | |
| ADD A, Rn | Add register to A | 1 | 1 |
| ADD A, direct | Add direct byte to A | 2 | 1 |
| ADD A, @Ri | Add data memory to A | 1 | 1 |
| ADD A, #data | Add immediate to A | 2 | 1 |
| ADDC A, Rn | Add register to A with carry | 1 | 1 |
| ADDC A, direct | Add direct byte to A with carry | 2 | 1 |
| ADDC A, @Ri | Add data memory to A with carry | 1 | 1 |
| ADDC A, #data | Add immediate to A with carry | 2 | 1 |
| SUBB A, Rn | Subtract register from A with borrow | 1 | 1 |
| SUBB A, direct | Subtract direct byte from A with borrow | 2 | 1 |
| SUBB A, @Ri | Subtract data mem from A with borrow | 1 | 1 |
| SUBB A, #data | Subtract immediate from A with borrow | 2 | 1 |
| INC A | Increment A | 1 | 1 |
| INC Rn | Increment register | 1 | 1 |
| INC direct | Increment direct byte | 2 | 1 |
| INC @Ri | Increment data memory | 1 | 1 |
| DEC A | Decrement A | 1 | 1 |
| DEC Rn | Decrement register | 1 | 1 |
| DEC direct | Decrement direct byte | 2 | 1 |
| DEC @Ri | Decrement data memory | 1 | 1 |
| INC DPTR | Increment data pointer | 1 | 2 |
| MUL AB | Multiply A by B | 1 | 4 |
| DIV AB | Divide A by B | 1 | 4 |
| DA A | Decimal adjust A | 1 | 1 |
| Logical Instructions | | | |
| ANL A, Rn | AND register to A | 1 | 1 |
| ANL A, direct | AND direct byte to A | 2 | 1 |
| ANL A, @Ri | AND data memory to A | 1 | 1 |
| ANL A, #data | AND immediate to A | 2 | 1 |
| ANL direct, A | AND A to direct byte | 2 | 1 |
| ANL direct, #data | AND immediate data to direct byte | 3 | 2 |
| ORL A, Rn | OR register to A | 1 | 1 |
| ORL A, direct | OR direct byte to A | 2 | 1 |
| ORL A, @Ri | OR data memory to A | 1 | 1 |
| ORL A, #data | OR immediate to A | 2 | 1 |
| ORL direct, A | OR A to direct byte | 2 | 1 |
| ORL direct, #data | OR immediate data to direct byte | 3 | 2 |
| XRL A, Rn | Exclusive-OR register to A | 1 | 1 |
| XRL A, direct | Exclusive-OR direct byte to A | 2 | 1 |
| XRL A, @Ri | Exclusive-OR data memory to A | 1 | 1 |
| XRL A, #data | Exclusive-OR immediate to A | 2 | 1 |
| XRL direct, A | Exclusive-OR A to direct byte | 2 | 1 |
| XRL direct, #data | Exclusive-OR immediate to direct byte | 3 | 2 |
| CLR A | Clear A | 1 | 1 |
| CPL A | Compliment A | 1 | 1 |
| SWAP A | Sw ap nibbles of A | 1 | 1 |
| RL A | Rotate A left | 1 | 1 |
| RLC A | Rotate A left through carry | 1 | 1 |
| RR A | Rotate A right | 1 | 1 |
| RRC A | Rotate A right through carry | 1 | 1 |

| Mnemonic | Description | Size (bytes) | Instr. Cycles |
|-----------------------------------|---------------------------------------|--------------|---------------|
| Boolean Instruction | | | |
| CLR C | Clear Carry bit | 1 | 1 |
| CLR bit | Clear bit | 2 | 1 |
| SETB C | Set Carry bit to 1 | 1 | 1 |
| SETB bit | Set bit to 1 | 2 | 1 |
| CPL C | Complement Carry bit | 1 | 1 |
| CPL bit | Complement bit | 2 | 1 |
| ANL C,bit | Logical AND between Carry and bit | 2 | 2 |
| ANL C,#bit | Logical AND between Carry and not bit | 2 | 2 |
| ORL C,bit | Logical ORL between Carry and bit | 2 | 2 |
| ORL C,#bit | Logical ORL between Carry and not bit | 2 | 2 |
| MOV C,bit | Copy bit value into Carry | 2 | 1 |
| MOV bit,C | Copy Carry value into Bit | 2 | 2 |
| Data Transfer Instructions | | | |
| MOV A, Rn | Move register to A | 1 | 1 |
| MOV A, direct | Move direct byte to A | 2 | 1 |
| MOV A, @Ri | Move data memory to A | 1 | 1 |
| MOV A, #data | Move immediate to A | 2 | 1 |
| MOV Rn, A | Move A to register | 1 | 1 |
| MOV Rn, direct | Move direct byte to register | 2 | 2 |
| MOV Rn, #data | Move immediate to register | 2 | 1 |
| MOV direct, A | Move A to direct byte | 2 | 1 |
| MOV direct, Rn | Move register to direct byte | 2 | 2 |
| MOV direct, direct | Move direct byte to direct byte | 3 | 2 |
| MOV direct, @Ri | Move data memory to direct byte | 2 | 2 |
| MOV direct, #data | Move immediate to direct byte | 3 | 2 |
| MOV @Ri, A | Move A to data memory | 1 | 1 |
| MOV @Ri, direct | Move direct byte to data memory | 2 | 2 |
| MOV @Ri, #data | Move immediate to data memory | 2 | 1 |
| MOV DPTR, #data | Move immediate to data pointer | 3 | 2 |
| MOVC A, @A+DPTR | Move code byte relative DPTR to A | 1 | 2 |
| MOVC A, @A+PC | Move code byte relative PC to A | 1 | 2 |
| MOVX A, @Ri | Move external data (A8) to A | 1 | 2 |
| MOVX A, @DPTR | Move external data (A16) to A | 1 | 2 |
| MOVX @Ri, A | Move A to external data (A8) | 1 | 2 |
| MOVX @DPTR, A | Move A to external data (A16) | 1 | 2 |
| PUSH direct | Push direct byte onto stack | 2 | 2 |
| POP direct | Pop direct byte from stack | 2 | 2 |
| XCH A, Rn | Exchange A and register | 1 | 1 |
| XCH A, direct | Exchange A and direct byte | 2 | 1 |
| XCH A, @Ri | Exchange A and data memory | 1 | 1 |
| XCHD A, @Ri | Exchange A and data memory nibble | 1 | 1 |
| Branching Instructions | | | |
| ACALL addr 11 | Absolute call to subroutine | 2 | 2 |
| LCALL addr 16 | Long call to subroutine | 3 | 2 |
| RET | Return from subroutine | 1 | 2 |
| RETI | Return from interrupt | 1 | 2 |
| AJMP addr 11 | Absolute jump unconditional | 2 | 2 |
| LJMP addr 16 | Long jump unconditional | 3 | 2 |
| SJMP rel | Short jump (relative address) | 2 | 2 |
| JC rel | Jump on carry = 1 | 2 | 2 |
| JNC rel | Jump on carry = 0 | 2 | 2 |
| JB bit, rel | Jump on direct bit = 1 | 3 | 2 |
| JNB bit, rel | Jump on direct bit = 0 | 3 | 2 |
| JBC bit, rel | Jump on direct bit = 1 and clear | 3 | 2 |
| JMP @A+DPTR | Jump indirect relative DPTR | 1 | 2 |
| JZ rel | Jump on accumulator = 0 | 2 | 2 |
| JNZ rel | Jump on accumulator != 0 | 2 | 2 |
| CJNE A, direct, rel | Compare A, direct JNE relative | 3 | 2 |
| CJNE A, #d, rel | Compare A, immediate JNE relative | 3 | 2 |
| CJNE Rn, #d, rel | Compare reg, immediate JNE relative | 3 | 2 |
| CJNE @Ri, #d, rel | Compare ind, immediate JNE relative | 3 | 2 |
| DJNZ Rn, rel | Decrement register, JNZ relative | 2 | 2 |
| DJNZ direct, rel | Decrement direct byte, JNZ relative | 3 | 2 |
| Miscellaneous Instruction | | | |
| NOP | No operation | 1 | 1 |

Rn: Any of the register R0 to R7
 @Ri: Indirect addressing using Register R0 or R1
 #data: immediate Data provided with Instruction
 #data 16: Immediate data included with instruction
 bit: address at the bit level
 rel: relative address to Program counter from +127 to -128
 Addr11: 11-bit address range
 Addr16: 16-bit address range
 #d: Immediate Data supplied with instruction

Special Function Registers (SFR)

Addresses 80h to FFh of the SFR address space can be accessed in direct addressing mode only. The following table lists the VRS550 and VRS560 Special Function Registers.

TABLE 5: SPECIAL FUNCTION REGISTERS (SFR)

| SFR Register | SFR Adrs | Bit 7 | Bit 6 | Bit 5 | Bit 4 | Bit 3 | Bit 2 | Bit 1 | Bit 0 | Reset Value |
|--------------|----------|---------|-------|-------|-------|-------|-------|-------|--------|-------------|
| P0 | 80h | - | - | - | - | - | - | - | - | |
| SP | 81h | - | - | - | - | - | - | - | - | |
| DPL | 82h | - | - | - | - | - | - | - | - | |
| DPH | 83h | - | - | - | - | - | - | - | - | |
| Reserved | 84h | | | | | | | | | |
| PCON | 87h | SMOD | - | - | - | GF1 | GF0 | PDOWN | IDLE | 0000000b |
| TCON | 88h | TF1 | TR1 | TF0 | TR0 | IE1 | IT1 | IE0 | IT0 | 0000000b |
| TMOD | 89h | GATE1 | C/T1 | M1.1 | M0.1 | GATE0 | C/T0 | M1.0 | M0.0 | 0000000b |
| TL0 | 8Ah | - | - | - | - | - | - | - | - | |
| TL1 | 8Bh | - | - | - | - | - | - | - | - | |
| TH0 | 8Ch | - | - | - | - | - | - | - | - | |
| TH1 | 8Dh | - | - | - | - | - | - | - | - | |
| P1 | 90h | - | - | - | - | - | - | - | - | |
| SCON | 98h | SM0 | SM1 | SM2 | REN | TB8 | RB8 | T1 | RI | 0000000b |
| SBUF | 99h | - | - | - | - | - | - | - | - | |
| WDTCN | 9Fh | WDTE | - | WDCLR | - | - | WDPS2 | WDPS1 | WDPS0 | 0*0**000b |
| P2 | A0h | - | - | - | - | - | - | - | - | |
| IE | A8h | EA | - | ET2 | ES | ET1 | EX1 | ET0 | EX0 | 0000000b |
| P3 | B0h | - | - | - | - | - | - | - | - | |
| IP | B8h | - | - | PT2 | PS | PT1 | PX1 | PT0 | PX0 | 0000000b |
| SYSCON | BFh | WDRESET | - | - | - | - | - | - | ALEI | 0*****0b |
| T2CON | C8h | TF2 | EXF2 | RCLK | TCLK | EXEN2 | TR2 | C/T2 | CP/RL2 | 0000000b |
| RCAP2L | CAh | - | - | - | - | - | - | - | - | 0000000b |
| RCAP2H | CBh | - | - | - | - | - | - | - | - | |
| TL2 | CCh | - | - | - | - | - | - | - | - | |
| TH2 | CDh | - | - | - | - | - | - | - | - | |
| PSW | D0h | CY | AC | F0 | RS1 | RS0 | OV | - | P | 0000000b |
| ACC | E0h | - | - | - | - | - | - | - | - | |
| B | F0h | - | - | - | - | - | - | - | - | |

Program Memory Structure

Program Memory

The VRS550 includes 8k of on-chip Flash that can be used as general program memory. The Flash memory size of the VRS560 is 16k.

FIGURE 3: VRS560 / VRS550 INTERNAL PROGRAM MEMORY

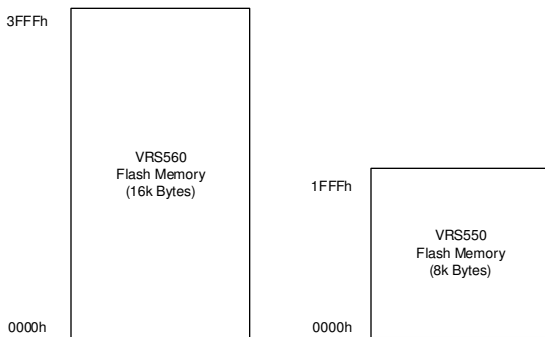

Program Status Word Register

The register below contains the program state flags. These flags may be read or written to by the user.

TABLE 6: PROGRAM STATUS WORD REGISTER (PSW) - SFR DOH

| | | | | | | | |
|----|----|----|-----|-----|----|---|---|
| 7 | 6 | 5 | 4 | 3 | 2 | 1 | 0 |
| CY | AC | F0 | RS1 | RS0 | OV | - | P |

| Bit | Mnemonic | Description |
|-----|----------|--------------------------------------|
| 7 | CY | Carry Bit |
| 6 | AC | Auxiliary Carry Bit from bit 3 to 4. |
| 5 | F0 | User definer flag |
| 4 | RS1 | R0-R7 Registers bank select bit 0 |
| 3 | RS0 | R0-R7 Registers bank select bit 1 |
| 2 | OV | Overflow flag |
| 1 | - | - |
| 0 | P | Parity flag |

| RS1 | RS0 | Active Bank | Address |
|-----|-----|-------------|---------|
| 0 | 0 | 0 | 00h-07h |
| 0 | 1 | 1 | 08h-0Fh |
| 1 | 0 | 2 | 10h-17h |
| 1 | 1 | 3 | 18-1Fh |

Data Pointer

The VRS550 and VRS560 have one 16-bit data pointer. The DPTR is accessed through two SFR addresses: DPL located at address 82h and DPH located at address 83h.

Data Memory

The VRS550 and the VRS560 have a total of: 256 bytes of RAM configured like the internal memory structure of a standard 8052.

FIGURE 4: VRS550 /VRS560 RAM MEMORY

| | | FF |
|---|---|----|
| Upper 128 bytes (Can only be accessed in indirect addressing mode) | SFR (Can only be accessed in direct addressing mode) | |
| Lower 128 bytes (Can be accessed in indirect and direct addressing mode) | | 80 |

Lower 128 bytes (00h to 7Fh, Bank 0 & Bank 1)

The lower 128 bytes of data memory (from 00h to 7Fh) can be summarized in the following points:

- Address range 00h to 7Fh can be accessed in direct and indirect addressing modes.
- Address range 00h to 1Fh includes R0-R7 registers area.
- Address range 20h to 2Fh is bit addressable.
- Address range 30h to 7Fh is not bit addressable and can be used as general-purpose storage.

Upper 128 bytes (80h to FFh, Bank 2 & Bank 3)

The upper 128 bytes of the data memory ranging from 80h to FFh can be accessed using indirect addressing or by using the bank mapping in direct addressing mode.

FIGURE 5: VRS550 / VRS560 RAM STRUCTURE

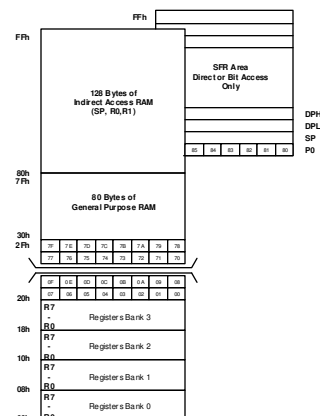

Description of Peripherals

System Control Register

The register represented in the following table is used for system control. The WDRESET bit (7) indicates if the system has been reset due to the overflow of the Watch Dog Timer.

The bit 0 of the SYSCON register is the ALE output inhibit bit. Setting this bit to 1 will inhibit the Fosc/6 clock signal output to the ALE pin.

TABLE 7: SYSTEM CONTROL REGISTER (SYSCON) – SFR BFH

| | | | | | | | |
|---------|--------|---|---|---|---|-------|------|
| 7 | 6 | 5 | 4 | 3 | 2 | 1 | 0 |
| WDRESET | Unused | | | | | XRAME | ALEI |

| Bit | Mnemonic | Description |
|-----|----------|--|
| 7 | WDRESET | This is the Watch Dog Timer reset bit. It will be set to 1 when the reset signal generated by WDT overflows. |
| 6 | Unused | - |
| 5 | Unused | - |
| 4 | Unused | - |
| 3 | Unused | - |
| 2 | Unused | - |
| 1 | Unused | - |
| 0 | ALEI | ALE output inhibit bit, which is used to reduce EMI. |

Power Control Register

The VRS550 / VRS560 devices provide two power saving modes: Idle and Power Down. These two modes serve to reduce the power consumption of the device.

In Idle mode, the processor is stopped but the oscillator is still running. The content of the RAM, I/O state and SFR registers are maintained. Timer operation is maintained, as well as the external interrupts.

This mode is useful for applications in which stopping the processor to save power is required. The processor will be woken up when an external event, triggering an interrupt, occurs.

In Power Down mode, the oscillator of the VRS550 / VRS560 is stopped. This means that all the peripherals are disabled. The content of the RAM and the SFR registers, however, is maintained.

The minimum VCC in Power down Mode is 2V

These power saving modes are controlled by the PDOWN and IDLE bits of the PCON register at address 87h.

TABLE 8: POWER CONTROL REGISTER (PCON) - SFR 87H

| | | | | | | | |
|--------|---|---|---|---|---|------|------|
| 7 | 6 | 5 | 4 | 3 | 2 | 1 | 0 |
| Unused | | | | | | RAM1 | RAM0 |

| Bit | Mnemonic | Description |
|-----|----------|--|
| 7 | SMOD | 1: Double the baud rate of the serial port frequency that was generated by Timer 1. 0: Normal serial port baud rate generated by Timer 1. |
| 6 | | |
| 5 | | |
| 4 | | |
| 3 | GF1 | General Purpose Flag |
| 2 | GF0 | General Purpose Flag |
| 1 | PDOWN | Power down mode control bit |
| 0 | IDLE | Idle mode control bit |

Input/Output Ports

The VRS550 and VRS560 have a total of 32 bi-directional I/O lines grouped in four 8-bit I/O ports. These I/Os can be individually configured as input or output

Except for the P0 I/Os, which are of the open drain type, each I/O is made of a transistor connected to ground and a weak pull-up resistor.

Writing a 0 in a given I/O port bit register will activate the transistor connected to ground, this will bring the I/O to a LOW level.

Writing a 1 into a given I/O port bit register deactivates the transistor between the pin and ground. In this case the pull-up resistor will bring the corresponding pin to a HIGH level.

To use a given I/O as an input, one must write a 1 into its associated port register bit.

By default, upon reset all the I/Os are configured as input.

General Structure of an I/O Port

The following elements establish the link between the core unit and the pins of the microcontroller:

- Special Function Register (same name as port)
- Output Stage Amplifier (the structure of this element varies with its auxiliary function)

From the next figure, one can see that the D flip-flop stores the value received from the internal bus after receiving a write signal from the core. Also, note that the Q output of the flip-flop can be linked to the internal bus by executing a read instruction.

This is how one would read the content of the register. It is also possible to link the value of the pin to the internal bus. This is done by the “read pin” instruction. In short, the user may read the value of the register or the pin.

FIGURE 6: INTERNAL STRUCTURE OF ONE OF THE EIGHT I/O PORT LINES

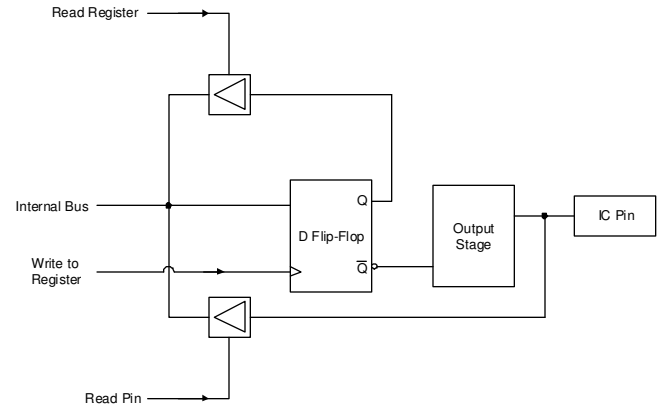

Structure of the P1, P2, P3

The following figure gives a general idea of the structure P1, P2 and P3 ports. Note that the figure below does not show the intermediary logic that connects the output of the register and the output stage together because this logic varies with the auxiliary function of each port.

FIGURE 7: GENERAL STRUCTURE OF THE OUTPUT STAGE OF P1, P2 AND P3

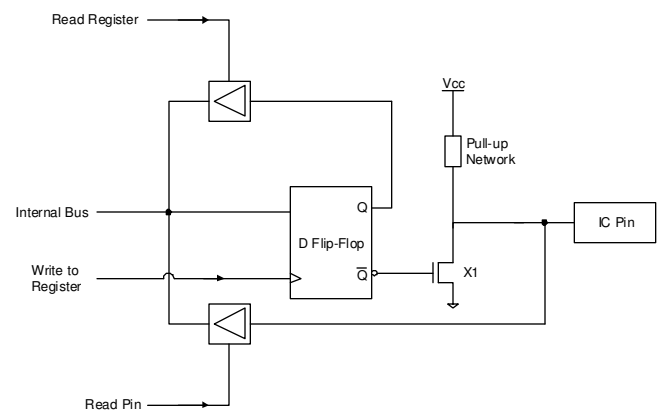

Each line may be used independently as a logical input or output. When used as an input, as mentioned earlier, the corresponding port register bit must be high.

Structure of Port 0

The internal structure of P0 is shown below. The auxiliary function of this port requires a particular logic. As opposed to the other ports, P0 is truly bi-directional. In other words, when used as an input, it is considered to be in a floating logical state (high impedance state). This arises from the absence of the internal pull-up resistance. The pull-up resistance is actually replaced by a transistor that is only used when the port functions to access external memory/data bus (EA=0).

When used as an I/O port, P0 acts as an open drain port and the use of an external pull-up resistor is likely to be required for most applications.

FIGURE 8: PORT P0'S PARTICULAR STRUCTURE

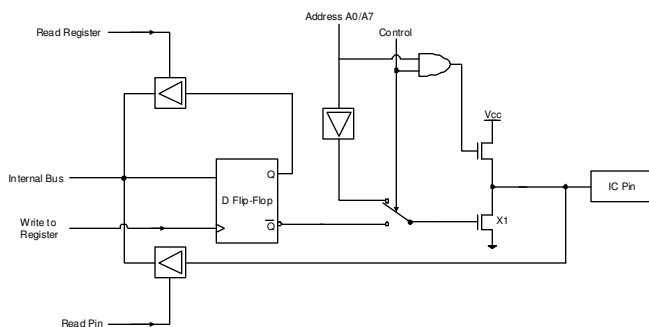

When P0 is used as an external memory bus input (for a MOVX instruction, for example), the outputs of the register are automatically forced to 1.

Port P0 and P2 as Address and Data Bus

The output stage may receive data from two sources

- The outputs of register P0 or the bus address itself multiplexed with the data bus for P0.
- The outputs of the P2 register or the high part (A8/A15) of the bus address for the P2 port.

FIGURE 9: P2 PORT STRUCTURE

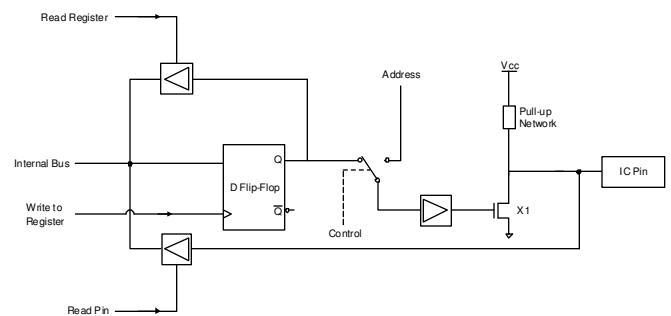

When the ports are used as an address or data bus, the special function registers P0 and P2 are disconnected from the output stage. The 8-bits of the P0 register are forced to 1 and the content of the P2 register remains constant.

Auxiliary Port 1 Functions

The port 1 I/O pins are shared with the T2EX and T2 inputs as shown below:

| Pin | Mnemonic | Function |
|------|----------|-------------------------|
| P1.0 | T2 | Timer 2 counter input |
| P1.1 | T2EX | Timer 2 Auxiliary input |
| P1.2 | | |
| P1.3 | | |
| P1.4 | | |
| P1.5 | | |
| P1.6 | | |
| P1.7 | | |

Auxiliary P3 Port Functions

The Port 3 I/O pins are shared with the UART interface, INT0 and INT1 interrupts, Timer 0 and Timer 1 inputs and finally the #WR and #RD lines when external memory access is performed.

FIGURE 10: P3 PORT STRUCTURE

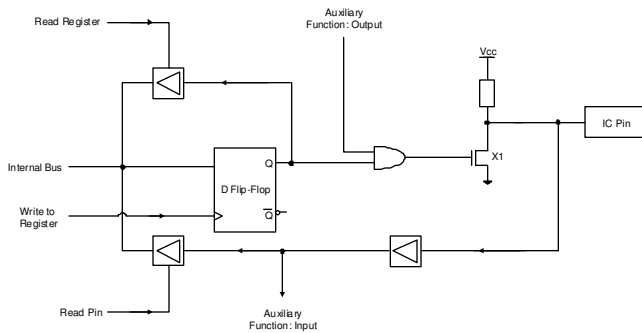

The following table describes the auxiliary function of the port 3 I/O pins.

TABLE 9: P3 AUXILIARY FUNCTION TABLE

| Pin | Mnemonic | Function |
|------|--------------------------|---|
| P3.0 | RXD | Serial Port: Receive data in asynchronous mode. Input and output data in synchronous mode. |
| P3.1 | TXD | Serial Port: Transmit data in asynchronous mode. Output clock value in synchronous mode. |
| P3.2 | $\overline{\text{INT0}}$ | External Interrupt 0 Timer 0 Control Input |
| P3.3 | $\overline{\text{INT1}}$ | External Interrupt 1 Timer 1 Control Input |
| P3.4 | T0 | Timer 0 Counter Input |
| P3.5 | T1 | Timer 1 Counter Input |
| P3.6 | $\overline{\text{WR}}$ | Write signal for external memory |
| P3.7 | $\overline{\text{RD}}$ | Read signal for external memory |

Software Particularities Concerning the Ports

Some instructions allow the user to read the logic state of the output pin, while others allow the user to read the content of the associated port register. These instructions are called *read-modify-write* instructions. A list of these instructions may be found in the table below.

Upon execution of these instructions, the content of the port register (at least 1 bit) is modified. The other read instructions take the present state of the input into account. For example, the instruction `ANL P3, #01h` obtains the value in the P3 register; performs the desired logic operation with the constant 01h; and recopies the result into the P3 register. When users want to take the present state of the inputs into account, they must first read these states and perform an AND operation between the reading and the constant.

```
MOV A, P3; State of the inputs in the accumulator
ANL A, #01; AND operation between P3 and 01h
```

When the port is used as an output, the register contains information on the state of the output pins. Measuring the state of an output directly on the pin is inaccurate because the electrical level depends mostly on the type of charge that is applied to it. The functions shown below take the value of the register rather than that of the pin.

TABLE 10: LIST OF INSTRUCTIONS THAT READ AND MODIFY THE PORT USING REGISTER VALUES

| Instruction | Function |
|-------------|---|
| ANL | Logical AND ex: <code>ANL P0, A</code> |
| ORL | Logical OR ex: <code>ORL P2, #01110000B</code> |
| XRL | Exclusive OR ex: <code>XRL P1, A</code> |
| JBC | Jump if the bit of the port is set to 0 |
| CPL | Complement one bit of the port |
| INC | Increment the port register by 1 |
| DEC | Decrement the port register by 1 |
| DJNZ | Decrement by 1 and jump if the result is not equal to 0 |
| MOV P., C | Copy the held bit C to the port |
| CLR P.x | Set the port bit to 0 |
| SETB P.x | Set the port bit to 1 |
| | |
| | |

Port Operation Timing

Writing to a Port (Output)

When an operation induces a modification of the content in a port register, the new value is placed at the output of the D flip-flop during the T12 period of the last machine cycle that the instruction needed to execute.

It is important to note, however, that the output stage only samples the output of the registers on the P1 phase of each period. It follows that the new value only appears at the output after the T12 period of the following machine cycle.

Reading a Port (Input)

The reading of an I/O pin takes place:

- During T9 cycle for P0, P1
- During T10 cycle for P2, P3
- When the ports are configured as I/Os (see Figure 25).

In order to get sampled, the signal duration present on the I/O inputs must have a duration longer than $F_{osc}/12$.

I/O Ports Driving Capability

The maximum allowable continuous current that the device can sink on I/O port is defined by the following:

| | |
|---|------|
| Maximum sink current on one given I/O | 10mA |
| Maximum total sink current for P0 | 26mA |
| Maximum total sink current for P1, 2, 3 | 15mA |
| Maximum total sink current on all I/O | 70mA |

It is not recommended to exceed the sink current expressed in the above table. Doing so is likely to make the low-level output voltage exceed the device's specification and it is likely to affect the device's reliability.

The VRS550 / VRS560 port are not designed to source current.

Timers

Both the VRS550 and VRS560 include three 16-bit timers: T0, T1 and T2.

The timers can operate in two specific modes:

- Event counting mode
- Timer mode

When operating in counting mode, the counter is incremented each time an external event, such as a transition in the logical state of the timer input (T0, T1, T2 input), is detected. When operating in timer mode, the counter is incremented by the microcontroller's direct clock pulse or by a divided version of this pulse.

Timer 0 and Timer 1

Timers 0 and 1 have four modes of operation. These modes allow the user to change the size of the counting register or to authorize an automatic reload when provided with a specific value. Timer 1 can even be used as a baud rate generator to generate communication frequencies for the serial interface.

Timer 1 and Timer 0 are configured by the TMOD and TCON registers.

TABLE 11: TIMER MODE CONTROL REGISTER (TMOD) – SFR 89H

| | | | | | | | |
|------|-----|----|----|------|-----|------|------|
| 7 | 6 | 5 | 4 | 3 | 2 | 1 | 0 |
| GATE | C/T | M1 | M0 | GATE | C/T | M1.0 | M0.0 |

| Bit | Mnemonic | Description |
|-----|----------|---|
| 7 | GATE1 | 1: Enables external gate control (pin INT1 for Counter 1). When INT1 is high, and TRx bit is set (see TCON register), a counter is incremented every falling edge on the T1IN input pin. |
| 6 | C/T1 | Selects timer or counter operation (Timer 1). 1 = A counter operation is performed 0 = The corresponding register will function as a timer. |
| 5 | M1.1 | Selects mode for Timer/Counter 1 |
| 4 | M0.1 | Selects mode for Timer/Counter 1 |
| 3 | GATE0 | If set, enables external gate control (pin INTO for Counter 0). When INTO is high, and TRx bit is set (see TCON register), a counter is incremented every falling edge on the T0IN input pin. |
| 2 | C/T0 | Selects timer or counter operation (Timer 0). 1 = A counter operation is performed 0 = The corresponding register will function as a timer. |
| 1 | M1.0 | Selects mode for Timer/Counter 0. |
| 0 | M0.0 | Selects mode for Timer/Counter 0. |

The table below summarizes the four modes of operation of timers 0 and 1. The timer-operating mode is selected by the bits M1 and M0 of the TMOD register.

TABLE 12: TIMER/COUNTER MODE DESCRIPTION SUMMARY

| M1 | M0 | Mode | Function |
|----|----|--------|--|
| 0 | 0 | Mode 0 | 13-bit Counter |
| 0 | 1 | Mode 1 | 16-bit Counter |
| 1 | 0 | Mode 2 | 8-bit auto-reload Counter/Timer. The reload value is kept in TH0 or TH1, while TL0 or TL1 is incremented every machine cycle. When TLx overflows, the value of THx is copied to TLx. |
| 1 | 1 | Mode 3 | If Timer 1 M1 and M0 bits are set to 1, Timer 1 stops. |

Timer 0 / Timer1 Counter / Timer Functions

Timing Function

When operating as a timer, the counter is automatically incremented at every machine cycle. A flag is raised in the event that an overflow occurs and the counter acquires a value of zero. These flags (TF0 and TF1) are located in the TCON register.

TABLE 13: TIMER 0 AND 1 CONTROL REGISTER (TCON) –SFR 88H

| | | | | | | | |
|-----|-----|-----|-----|-----|-----|-----|-----|
| 7 | 6 | 5 | 4 | 3 | 2 | 1 | 0 |
| TF1 | TR1 | TF0 | TR0 | IE1 | IT1 | IE0 | IT0 |

| Bit | Mnemonic | Description |
|-----|----------|---|
| 7 | TF1 | Timer 1 Overflow Flag. Set by hardware on Timer/Counter overflow. Cleared by hardware on Timer/Counter overflow. Cleared by hardware when processor vectors to interrupt routine. |
| 6 | TR1 | Timer 1 Run Control Bit. Set/cleared by software to turn Timer/Counter on or off. |
| 5 | TF0 | Timer 0 Overflow Flag. Set by hardware on Timer/Counter overflow. Cleared by hardware when processor vectors to interrupt routine. |
| 4 | TR0 | Timer 0 Run Control Bit. Set/cleared by software to turn Timer/Counter on or off. |
| 3 | IE1 | Interrupt Edge Flag. Set by hardware when external interrupt edge is detected. Cleared when interrupt processed. |
| 2 | IT1 | Interrupt 1 Type Control Bit. Set/cleared by software to specify falling edge/low level triggered external interrupts. |
| 1 | IE0 | Interrupt 0 Edge Flag. Set by hardware when external interrupt edge is detected. Cleared when interrupt processed. |
| 0 | IT0 | Interrupt 0 Type control bit. Set/cleared by software to specify falling edge/low level triggered external interrupts. |

Counting Function

When operating as a counter, the timer's register is incremented at every falling edge of the T0, T1 and T2 signals located at the input of the timer. In this case, the signal is sampled at the T10 phase of each machine cycle for Timer 0, Timer 1 and T9 for Timer 2.

When the sampler sees a high immediately followed by a low in the next machine cycle, the counter is incremented. Two machine cycles are required to detect and record an event. This reduces the counting frequency by a factor of 24 (24 times less than the oscillator's frequency).

Operating Modes

The user may change the operating mode by varying the M1 and M0 bits of the TMOD SFR.

Mode 0

A schematic representation of this mode of operation can be found below in Figure 10. From the figure, we notice that the timer operates as an 8-bit counter preceded by a divide-by-32 prescaler made of the 5LSB of TL1. The register of the counter is configured to be 13 bits long. When an overflow causes the value of the register to roll over to 0, the TFx interrupt signal goes to 1. The count value is validated as soon as TRx goes to 1 and the GATE bit is 0, or when INTx is 1.

FIGURE 11: TIMER/COUNTER 1 MODE 0: 13-BIT COUNTER

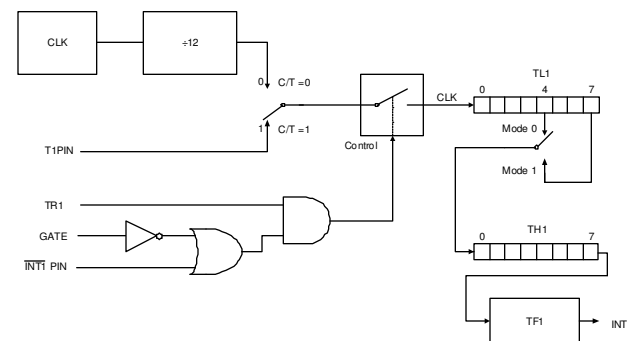

Mode 1

Mode 1 is almost identical to Mode 0. They differ in that, in Mode 1, the counter uses the full 16-bits and has no prescaler.

Mode 2

In this mode, the register of the timer is configured as an 8-bit automatically re-loadable counter. In Mode 2, it is the lower byte TLx that is used as the counter. In the event of a counter overflow, the TFx flag is set to 1 and the value contained in THx, which is preset by software, is reloaded into the TLx counter. The value of THx remains unchanged.

FIGURE 12: TIMER/COUNTER 1 MODE 2: 8-BIT AUTOMATIC RELOAD

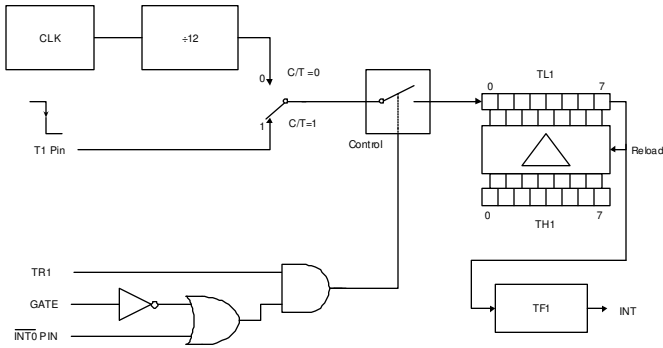

Mode 3

In Mode 3, Timer 1 is blocked as if its control bit, TR1, was set to 0. In this mode, Timer 0's registers TL0 and TH0 are configured as two separate 8-bit counters. Also, the TL0 counter uses Timer 0's control bits C/T, GATE, TR0, INT0, TF0 and the TH0 counter is held in Timer Mode (counting machine cycles) and gains control over TR1 and TF1 from Timer 1. At this point, TH0 controls the Timer 1 interrupt.

FIGURE 13: TIMER/COUNTER 0 MODE 3

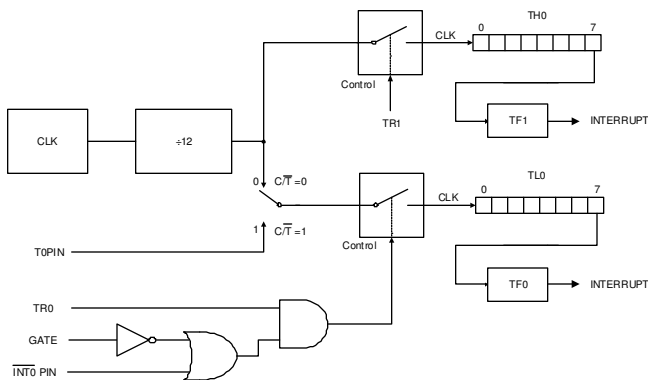

When EXEN2 = 1, the above still applies. In addition, it is possible to allow a 1 to 0 transition at the T2EX input to cause the current value stored in the Timer 2 registers (TL2 and TH2) to be captured into the RCAP2L and RCAP2H registers. Furthermore, the transition at T2EX causes bit EXF2 in T2CON to be set, and EXF2, like TF2, can generate an interrupt. Note that both EXF2 and TF2 share the same interrupt vector.

Auto-Reload Mode

In this mode, there are also two options. The user may choose either option by writing to bit EXEN2 in T2CON.

If EXEN2 = 0, when Timer 2 rolls over, it not only sets TF2, but also causes the Timer 2 registers to be reloaded with the 16-bit value in the RCAP2L and RCAP2H registers previously initialised. In this mode, Timer 2 can be used as a baud rate generator source for the serial port.

If EXEN2=1, then Timer 2 still performs the above operation, but a 1 to 0 transition at the external T2EX input will also trigger an anticipated reload of the Timer 2 with the value stored in RCAP2L, RCAP2H and set EXF2.

FIGURE 15: TIMER 2 IN AUTO-RELOAD MODE

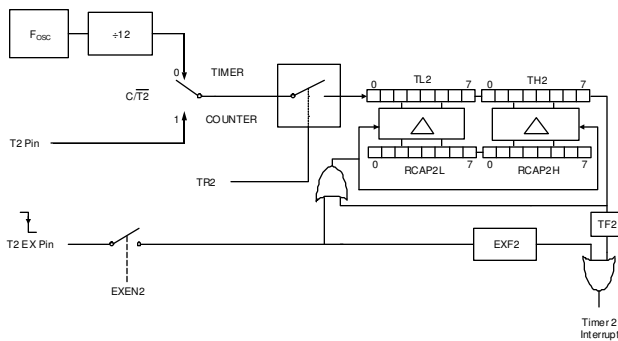

Baud Rate Generator Mode

The baud rate generator mode is activated when RCLK is set to 1 and/or TCLK is set to 1. This mode will be described in the serial port section.

FIGURE 16: TIMER 2 IN AUTOMATIC BAUD GENERATOR MODE

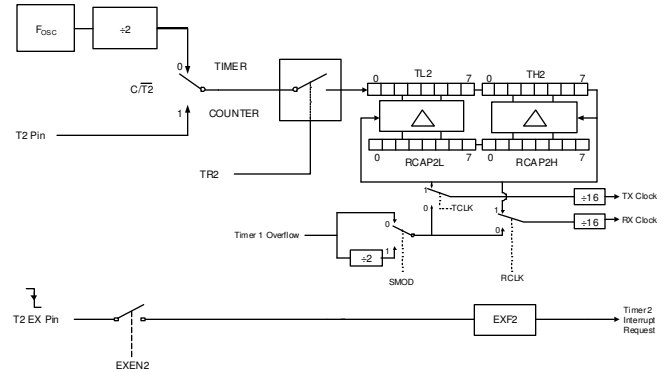

Serial Port

The serial port included in the VRS550 and VRS560 can operate in full duplex; in other words, it can transmit and receive data simultaneously. This occurs at the same speed if one timer is assigned as the clock source for both transmission and reception, and at different speeds if transmission and reception are each controlled by their own timer.

The serial port receive is buffered, which means that it can begin reception of a byte even if the one previously received byte has not been retrieved from the receive register by the processor. However, if the first byte has still not been read by the time reception of the second byte is complete, the byte present in the receive buffer will be lost.

One SFR register, SBUF, gives access to the transmit and receive registers of the serial port. When users read from the SBUF register, they will access the receive register. When users write to the SBUF, the transmit register will be loaded.

Serial Port Control Register

The serial port control register and status register SCON contain the 9th data bit for transmit and receive (TB8 and RB8) and all the mode selection bits. SCON also contains the serial port interrupt bits (TI and RI).

TABLE 16: SERIAL PORT CONTROL REGISTER (SCON) – SFR 98H

| | | | | | | | |
|-----|-----|-----|-----|-----|-----|----|----|
| 7 | 6 | 5 | 4 | 3 | 2 | 1 | 0 |
| SM0 | SM1 | SM2 | REN | TB8 | RB8 | TI | RI |

| Bit | Mnemonic | Description |
|-----|----------|--|
| 7 | SM0 | Bit to select mode of operation (see table below) |
| 6 | SM1 | Bit to select mode of operation (see table below) |
| 5 | SM2 | Multiprocessor communication is possible in modes 2 and 3. In modes 2 or 3 if SM2 is set to 1, RI will not be activated if the received 9 th data bit (RB8) is 0. In Mode 1, if SM2 = 1 then RI will not be activated if a valid stop bit was not received. |
| 4 | REN | Serial Reception Enable Bit This bit must be set by software and cleared by software. 1: Serial reception enabled 0: Serial reception disabled |

| | | |
|---|-----|--|
| 3 | TB8 | 9 th data bit transmitted in modes 2 and 3 This bit must be set by software and cleared by software. |
| 2 | RB8 | 9 th data bit received in modes 2 and 3. In Mode 1, if SM2 = 0, RB8 is the stop bit that was received. In Mode 0, this bit is not used. This bit must be cleared by software. |
| 1 | TI | Transmission Interrupt flag. Automatically set to 1 when: <ul style="list-style-type: none"> The 8th bit has been sent in Mode 0. Automatically set to 1 when the stop bit has been sent in the other modes. This bit must be cleared by software. |
| 0 | RI | Reception Interrupt flag Automatically set to 1 when: <ul style="list-style-type: none"> The 8th bit has been received in Mode 0. Automatically set to 1 when the stop bit has been sent in the other modes (see SM2 exception). This bit must be cleared by software. |

TABLE 17: SERIAL PORT MODES OF OPERATION

| SM0 | SM1 | Mode | Description | Baud Rate |
|-----|-----|------|----------------|------------------------------|
| 0 | 0 | 0 | Shift Register | $F_{osc}/12$ |
| 0 | 1 | 1 | 8-bit UART | Variable |
| 1 | 0 | 2 | 9-bit UART | $F_{osc}/64$ or $F_{osc}/32$ |
| 1 | 1 | 3 | 9-bit UART | Variable |

Modes of Operation

The VRS550 / VRS560 devices serial port can operate in four different modes. In all four modes, a transmission is initiated by an instruction that uses the SBUF SFR as a destination register. In Mode 0, reception is initiated by setting RI to 0 and REN to 1. An incoming start bit initiates reception in the other modes provided that REN is set to 1. The following paragraphs describe the four modes.

Mode 0

In this mode, the serial data exits and enters through the RXD pin. TXD is used to output the shift clock. The signal is composed of 8 data bits starting with the LSB. The baud rate in this mode is 1/12 the oscillator frequency.

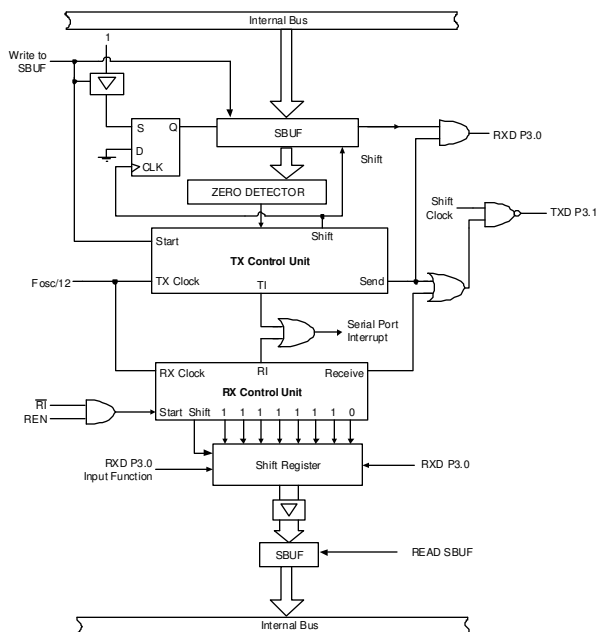

FIGURE 17: SERIAL PORT MODE 0 BLOCK DIAGRAM

Transmission in Mode 0

Any instruction that uses SBUF as a destination register may initiate a transmission. The “write to SBUF” signal also loads a 1 into the 9th position of the transmit shift register and tells the TX control block to begin a transmission. The internal timing is such that one full machine cycle will elapse between a write to SBUF instruction and the activation of SEND.

The SEND signal enables the output of the shift register to the alternate output function line of P3.0 and enables SHIFT CLOCK to the alternate output function line of P3.1. SHIFT CLOCK is high during T11, T12 and T1, T2 and T3, T4 of every machine cycle and low during T5, T6, T7, T8, T9 and T10. At T12 of every machine cycle in which SEND is active, the contents of the transmit shift register are shifted to the right by one position.

Zeros come in from the left as data bits shift out to the right. The TX control block sends its final shift and deactivates SEND while setting T1 after one condition is fulfilled: When the MSB of the data byte is at the output position of the shift register; the 1 that was initially loaded into the 9th position is just to the left of the MSB; and all positions to the left of that contain zeros. Once these conditions are met, the deactivation of SEND and the setting of T1 occur at T1 of the 10th machine cycle after the “write to SBUF” pulse.

Reception in Mode 0

When REN and R1 are set to 1 and 0 respectively, reception is initiated. The bits 11111110 are written to the receive shift register at T12 of the next machine cycle by the RX control unit. In the following phase, the RX control unit will activate RECEIVE.

SHIFT CLOCK to the alternate output function line of P3.1 is enabled by RECEIVE. At every machine cycle, SHIFT CLOCK makes transitions at T5 and T11. The contents of the receive shift register are shifted one position to the left at T12 of every machine in which RECEIVE is active. The value that comes in from the right is the value that was sampled at the P3.0 pin at T10 of the same machine cycle.

1’s are shifted out to the left as data bits are shifted in from the right. The RX control block is flagged to do one last shift and load SBUF when the 0 that was initially loaded into the rightmost position arrives at the leftmost position in the shift register.

Mode 1

For an operation in Mode 1, 10 bits are transmitted through TXD or received through RXD. The transactions are composed of: a Start bit (Low), 8 data bits (LSB first) and one Stop bit (high). The reception is completed once the Stop bit sets the RB8 flag in the SCON register. Either Timer 1 or Timer 2 controls the baud rate in this mode.

The following diagram shows the serial port structure when configured in Mode 1.

FIGURE 18: SERIAL PORT MODE 1 AND 3 BLOCK DIAGRAM

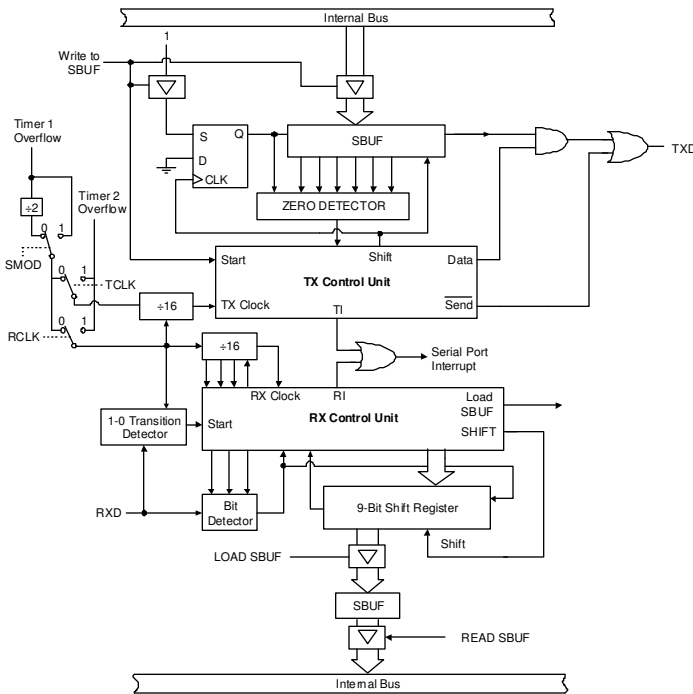

Transmission in Mode 1

Transmission is initiated by any instruction that makes use of SBUF as a destination register. The 9th bit position of the transmit shift register is loaded by the “write to SBUF” signal. This event also flags the TX Control Unit that a transmission has been requested.

It is after the next rollover in the divide-by-16 counter when transmission actually begins at T1 of the machine cycle. It follows that the bit times are synchronized to the divide-by-16 counter and not to the “write to SBUF” signal.

When a transmission begins, it places the start bit at TXD. Data transmission is activated one bit time later. This activation enables the output bit of the transmit shift register to TXD. One bit time after that, the first shift pulse occurs.

In this mode, zeros are clocked in from the left as data bits are shifted out to the right. When the most significant bit of the data byte is at the output position of the shift register, the 1 that was initially loaded into the 9th position is to the immediate left of the MSB, and all positions to the left of that contain zeros. This condition flags the TX Control Unit to shift one more time.

Reception in Mode 1

One to zero transitions at RXD initiate reception. It is for this reason that RXD is sampled at a rate of 16 multiplied by the baud rate that has been established. When a transition is detected, 1FFh is written into the input shift register and the divide-by-16 counter is immediately reset. The divide-by-16 counter is reset in order to align its rollovers with the boundaries of the incoming bit times.

In total, there are 16 states in the counter. During the 7th, 8th and 9th counter states of each bit time; the bit detector samples the value of RXD. The accepted value is the value that was seen in at least two of the three samples. The purpose of doing this is for noise rejection. If the value accepted during the first bit time is not zero, the receive circuits are reset and the unit goes back to searching for another one to zero transition. All false start bits are rejected by doing this. If the start bit is valid, it is shifted into the input shift register, and the reception of the rest of the frame will proceed.

For a receive operation, the data bits come in from the right as 1’s shift out on the left. As soon as the start bit arrives at the leftmost position in the shift register, (9-bit register), it tells the RX control block to perform one last shift operation: to set RI and to load SBUF and RB8. The signal to load SBUF and RB8, and to set RI, will be generated if, and only if, the following conditions are met at the time the final shift pulse is generated:

- Either SM2 = 0 or the received stop bit = 1
- RI = 0

If both conditions are met, the stop bit goes into RB8, the 8 data bits go into SBUF, and RI is activated. If one of these conditions is not met, the received frame is completely lost. At this time, whether the above conditions are met or not, the unit goes back to searching for a one to zero transition in RXD.

Mode 2

In Mode 2 a total of 11 bits are transmitted through TXD or received through RXD. The transactions are composed of: a Start bit (Low), 8 data bits (LSB first), a programmable 9th data bit, and one Stop bit (High).

For transmission, the 9th data bit comes from the TB8 bit of SCON. For example, the parity bit P in the PSW could be moved into TB8.

In the case of receive, the 9th data bit is automatically written into RB8 of the SCON register.

In Mode 2, the baud rate is programmable to either 1/32 or 1/64 the oscillator frequency.

FIGURE 19: SERIAL PORT MODE 2 BLOCK DIAGRAM

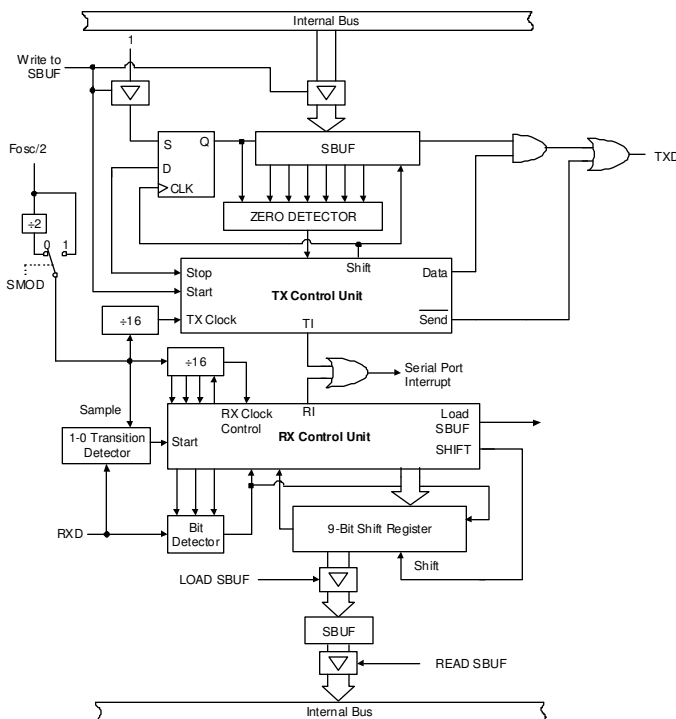

Mode 3

In Mode 3, 11 bits are transmitted through TXD or received through RXD. The transactions are composed of: a Start bit (Low), 8 data bits (LSB first), a programmable 9th data bit, and one Stop bit (High).

Mode 3 is identical to Mode 2 in all respects but one; the baud rate. Either Timer 1 or Timer 2 generates the baud rate in Mode 3.

FIGURE 20: SERIAL PORT MODE 3 BLOCK DIAGRAM

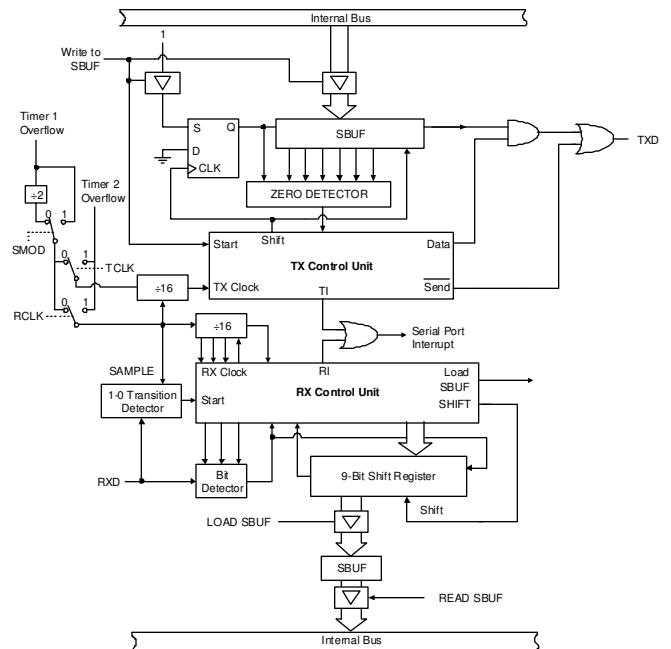

Mode 2 and 3: Additional Information

As mentioned earlier, for an operation in these modes, 11 bits are transmitted through TXD or received through RXD. The signal comprises: a logical low Start bit, 8 data bits (LSB first), a programmable 9th data bit, and one logical high Stop bit.

On transmit, (TB8 in SCON) can be assigned the value of 0 or 1. On receive; the 9th data bit goes into RB8 in SCON. The baud rate is programmable to either 1/32 or 1/64 the oscillator frequency in Mode 2. Mode 3 may have a variable baud rate generated from either Timer 1 or Timer 2 depending on the states of TCLK and RCLK.

Transmission in Mode 2 and Mode 3

The transmission is initiated by any instruction that makes use of SBUF as the destination register. The 9th bit position of the transmit shift register is loaded by the "write to SBUF" signal. This event also informs the TX control unit that a transmission has been requested. After the next rollover in the divide-by-16 counter, a transmission actually begins at T1 of the machine cycle. The bit times are synchronized to the divide-by-16 counter and not to the "write to SBUF" signal, as in the previous mode.

Transmissions begin when the SEND signal is activated, which places the Start bit at TXD. Data is activated one bit time later. This activation enables the output bit of the transmit shift register to TXD. The first shift pulse occurs one bit time after that.

The first shift clocks a Stop bit (1) into the 9th bit position of the shift register to TXD. Thereafter, only zeros are clocked in. Thus, as data bits shift out to the right, zeros are clocked in from the left. When TB8 is at the output position of the shift register, the stop bit is just to the left of TB8, and all positions to the left of that contain zeros. This condition signals to the TX control unit to shift one more time and set T1, while deactivating SEND. This occurs at the 11th divide-by-16 rollover after "write to SBUF".

Reception in Mode 2 and Mode 3

One to zero transitions at RXD initiate reception. It is for this reason that RXD is sampled at a rate of 16 multiplied by the baud rate that has been established. When a transition is detected, the 1FFh is written into the input shift register and the divide-by-16 counter is immediately reset.

During the 7th, 8th and 9th counter states of each bit time; the bit detector samples the value of RXD. The accepted value is the value that was seen in at least two of the three samples. If the value accepted during the first bit time is not zero, the receive circuits are reset and the unit goes back to searching for another one to zero transition. If the start bit is valid, it is shifted into the input shift register, and the reception of the rest of the frame will proceed.

For a receive operation, the data bits come in from the right as 1's shift out on the left. As soon as the start bit arrives at the leftmost position in the shift register (9-bit register), it tells the RX control block to do one more shift, to set RI, and to load SBUF and RB8. The signal to set RI and to load SBUF and RB8 will be generated if, and only if, the following conditions are satisfied at the instance when the final shift pulse is generated:

- Either SM2 = 0 or the received 9th bit is equal to 1
- RI = 0

If both conditions are met, the 9th data bit received goes into RB8, and the first 8 data bits go into SBUF. If one of these conditions is not met, the received frame is completely lost. One bit time later, whether the above conditions are met or not, the unit goes back to searching for a one to zero transition at the RXD input. Please note that the value of the received stop bit is unrelated to SBUF, RB8 or RI.

UART Baud Rates Calculation

In Mode 0, the baud rate is fixed and can be represented by the following formula:

$$\text{Mode 0 Baud Rate} = \frac{\text{Oscillator Frequency}}{12}$$

In Mode 2, the baud rate depends on the value of the SMOD bit in the PCON SFR. From the formula below, we can see that if SMOD = 0 (which is the value on reset), the baud rate is 1/32 the oscillator frequency.

$$\text{Mode 2 Baud Rate} = \frac{2^{\text{SMOD}} \times (\text{Oscillator Frequency})}{64}$$

The Timer 1 and/or Timer 2 overflow rate determines the baud rates in modes 1 and 3.

Generating Baud Rate with Timer 1

When Timer 1 functions as a baud rate generator, the baud rate in modes 1 and 3 are determined by the Timer 1 overflow rate.

$$\text{Mode 1, 3 Baud Rate} = \frac{2^{\text{SMOD}} \times \text{Timer 1 Overflow Rate}}{32}$$

Timer 1 must be configured as an 8-bit timer (TL1) with auto-reload with TH1 value when an overflow occurs (Mode 2). In this application, the Timer 1 interrupt should be disabled.

The two following formulas can be used to calculate the baud rate and the reload value to put in the TH1 register.

$$\text{Mode 1, 3 Baud Rate} = \frac{2^{\text{SMOD}} \times \text{Fosc}}{32 \times 12(256 - \text{TH1})}$$

The value to put into the TH1 register is defined by the following formula:

$$\text{TH1} = 256 - \frac{2^{\text{SMOD}} \times \text{Fosc}}{32 \times 12 \times (\text{Baud Rate})}$$

It is possible to use Timer 1 in 16-bit mode to generate the baud rate for the serial port. To do this, leave the Timer 1 interrupt enabled, configure the timer to run as a 16-bit timer (high nibble of TMOD = 0001B), and use the Timer 1 interrupt to perform a 16-bit software reload. This can achieve very low baud rates.

Generating Baud Rates with Timer 2

Timer 2 is often preferred to generate the baud rate, as it can be easily configured to operate as a 16-bit timer with auto-reload. This allows for much better resolution than using Timer 1 in 8-bit auto-reload mode.

The baud rate using Timer 2 is defined as:

$$\text{Mode 1, 3 Baud Rate} = \frac{\text{Timer 2 Overflow Rate}}{16}$$

The timer can be configured as either a timer or a counter in any of its 3 running modes. In most typical application, it is configured as a timer (C/T2 is set to 0).

To make the Timer 2 operate as a baud rate generator the TCLK and RCLK bits of the T2CON register must be set to 1.

The baud rate generator mode is similar to the auto-reload mode in that an overflow in TH2 causes the Timer 2 registers to be reloaded with the 16-bit value in registers RCAP2H and RCAP2L, which are preset by software. However, when Timer 2 is configured as a baud rate generator, its clock source is Osc/2.

The following formula can be used to calculate the baud rate in modes 1 and 3 using the Timer 2:

$$\text{Modes 1, 3 Baud Rate} = \frac{\text{Oscillator Frequency}}{32 \times [65536 - (\text{RCAP2H}, \text{RCAP2L})]}$$

The formula below is used to define the reload value to put into the RCAP2h, RCAP2L registers to achieve a given baud rate.

$$(\text{RCAP2H}, \text{RCAP2L}) = 65536 - \frac{\text{Fosc}}{32 \times [\text{Baud Rate}]}$$

In the above formula, RCAP2H and RCAP2L are the content of RCAP2H and RCAP2L taken as a 16-bit unsigned integer.

Note that a rollover in TH2 does not set TF2, and will not generate an interrupt. Because of this, the Timer 2 interrupt does not have to be disabled when Timer 2 is configured in baud rate generator mode.

Also, if EXEN2 is set, a 1-to-0 transition in T2EX will set EXF2 but will not cause a reload from RCAP2x to Tx2. Therefore, when Timer 2 is used as a baud rate generator, T2EX can be used as an extra external interrupt.

Furthermore, when Timer 2 is running (TR2 is set to 1) as a timer in baud rate generator mode, the user should not try to read or write to TH2 or TL2. When operating under these conditions, the timer is being incremented every state time and the results of a read or write command may be inaccurate.

The RCAP2 registers, however, may be read but should not be written to, because a write may overlap a reload operation and generate write and/or reload errors. In this case, before accessing the Timer 2 or RCAP2 registers, be sure to turn the timer off by clearing TR2.

Interrupts

The VRS550 and VRS560 have 8 interrupt sources (9 if we include the WDT) and 7 interrupt vectors (including reset) to handle them.

The interrupt can be enabled via the IE register shown below:

TABLE 18: IEN0 INTERRUPT ENABLE REGISTER –SFR A8H

| | | | | | | | |
|----|---|-----|----|-----|-----|-----|-----|
| 7 | 6 | 5 | 4 | 3 | 2 | 1 | 0 |
| EA | - | ET2 | ES | ET1 | EX1 | ET0 | EX0 |

| Bit | Mnemonic | Description |
|-----|----------|--|
| 7 | EA | Disables All Interrupts 0: no interrupt acknowledgment 1: Each interrupt source is individually enabled or disabled by setting or clearing its enable bit. |
| 6 | - | Reserved |
| 5 | ET2 | Timer 2 Interrupt Enable Bit |
| 4 | ES | Serial Port Interrupt Enable Bit |
| 3 | ET1 | Timer 1 Interrupt Enable Bit |
| 2 | EX1 | External Interrupt 1 Enable Bit |
| 1 | ET0 | Timer 0 Interrupt Enable Bit |
| 0 | EX0 | External Interrupt 0 Enable Bit |

The following figure illustrates the various interrupt sources on the VRS550 / VRS560.

FIGURE 21: INTERRUPT SOURCES

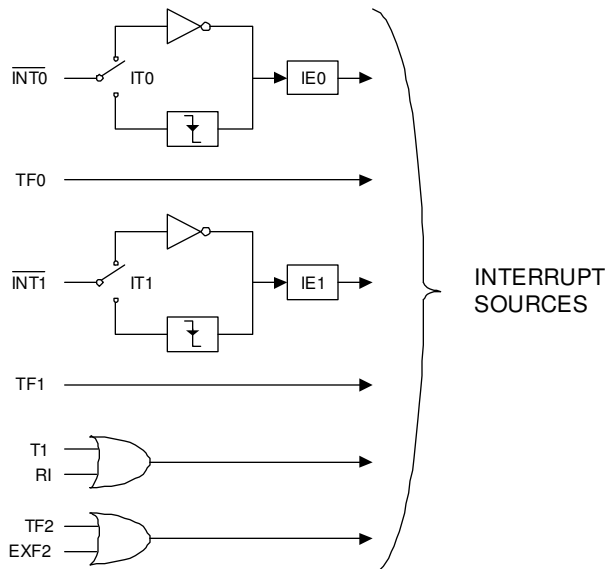

Interrupt Vectors

The table below specifies each interrupt source, its flag and its vector address.

TABLE 19: INTERRUPT VECTOR CORRESPONDING FLAGS AND VECTOR ADDRESS

| Interrupt Source | Flag | Vector Address |
|------------------|----------|----------------|
| RESET (+ WDT) | WDRESET | 0000h |
| INT0 | IE0 | 0003h |
| Timer 0 | TF0 | 000Bh |
| INT1 | IE1 | 0013h |
| Timer 1 | TF1 | 001Bh |
| Serial Port | RI+TI | 0023h |
| Timer 2 | TF2+EXF2 | 002Bh |

External Interrupts

The VRS550 and the VRS560 have two external interrupt inputs named INT0 and INT1. These interrupt lines are shared with P3.2 and P3.3.

The bits IT0 and IT1 of the TCON register determine whether the external interrupts are level or edge sensitive.

If $ITx = 1$, the interrupt will be raised when a 1-> 0 transition occurs at the interrupt pin. For the interrupt to be noticed by the processor, the duration of the sum high and low condition must be at least equal to 12 oscillator cycles.

If $ITx = 0$, the interrupt will occur when a logic low condition is present on the interrupt pin.

The state of the external interrupt, when enabled, can be monitored using the flags, IE0 and IE1 of the TCON register that are set when the interrupt condition occurs.

In the case where the interrupt was configured as edge sensitive, the associated flag is automatically cleared when the interrupt is serviced.

If the interrupt is configured as level sensitive, then the interrupt flag must be cleared by the software.

Timer 0 and Timer 1 Interrupt

Both Timer 0 and Timer 1 can be configured to generate an interrupt when a rollover of the timer/counter occurs (except Timer 0 in Mode 3).

The TF0 and TF1 flags serve to monitor timer overflow occurring from Timer 0 and Timer 1. These interrupt flags are automatically cleared when the interrupt is serviced.

Timer 2 Interrupt

Timer 2 interrupt can occur if TF2 and/or EXF2 flags are set to 1 and if the Timer 2 interrupt is enabled.

The TF2 flag is set when a rollover of Timer 2 Counter/Timer occurs. The EXF2 flag can be set by a 1->0 transition on the T2EX pin by the software.

Note that neither flag is cleared by the hardware upon execution of the interrupt service routine. The service routine may have to determine whether it was TF2 or EXF2 that generated the interrupt. These flag bits will have to be cleared by the software.

Every bit that generates interrupts can either be cleared or set by the software, yielding the same result as when the operation is done by the hardware. In other words, pending interrupts can be cancelled and interrupts can be generated by the software.

Serial Port Interrupt

The serial port can generate an interrupt upon byte reception or once the byte transmission is completed.

Those two conditions share the same interrupt vector and it is up to the interrupt service routine to find out what caused the interrupt by looking at the serial interrupt flags RI and TI.

Note that neither of these flags is cleared by the hardware upon execution of the interrupt service routine. The software must clear these flags.

Execution of an Interrupt

When the processor receives an interrupt request, an automatic jump to the desired subroutine occurs. This jump is similar to executing a branch to a subroutine instruction: the processor automatically saves the address of the next instruction on the stack. An internal flag is set to indicate that an interrupt is taking place, and then the jump instruction is executed. An interrupt subroutine must always end with the RETI instruction. This instruction allows users to retrieve the return address placed on the stack.

The RETI instruction also allows updating of the internal flag that will take into account an interrupt with the same priority.

Interrupt Enable and Interrupt Priority

When the VRS550 / VRS560 is initialized, all interrupt sources are inhibited by the bits of the IE register being reset to 0. It is necessary to start by enabling the interrupt sources that the application requires. This is achieved by setting bits in the IE register, as discussed previously.

This register is part of the bit addressable internal RAM. For this reason, it is possible to modify each bit individually in one instruction without having to modify the other bits of the register. All interrupts can be inhibited by setting EA to 0.

The order in which interrupts are serviced is shown in the following table:

TABLE 20: INTERRUPT NATURAL PRIORITY

| Interrupt Source |
|--------------------------------|
| RESET + WDT (Highest Priority) |
| IE0 |
| TF0 |
| IE1 |
| TF1 |
| RI+TI |
| TF2+EXF2 (Lowest Priority) |



Modifying the Interrupt Order of Priority

The VRS550 / VRS560 allows the user to modify the natural priority of the interrupts. One may modify the order by programming the bits in the IP (Interrupt Priority) register. When any bit in this register is set to 1, it gives the corresponding source a greater priority than interrupts coming from sources that don't have their corresponding IP bit set to 1.

The IP register is represented in the table below.

TABLE 21: IP INTERRUPT PRIORITY REGISTER –SFR B8H

| | | | | | | | |
|----|---|-----|----|-----|-----|-----|-----|
| 7 | 6 | 5 | 4 | 3 | 2 | 1 | 0 |
| EA | - | ET2 | ES | ET1 | EX1 | ET0 | EX0 |

| Bit | Mnemonic | Description |
|-----|----------|---|
| 7 | - | |
| 6 | - | |
| 5 | PT2 | Gives Timer 2 Interrupt Higher Priority |
| 4 | PS | Gives Serial Port Interrupt Higher Priority |
| 3 | PT1 | Gives Timer 1 Interrupt Higher Priority |
| 2 | PX1 | Gives INT1 Interrupt Higher Priority |
| 1 | PT0 | Gives Timer 0 Interrupt Higher Priority |
| 0 | PX0 | Gives INT0 Interrupt Higher Priority |

Watch Dog Timer

The Watch Dog Timer (WDT) is a 16-bit free-running counter that generates a reset signal if the counter overflows. The WDT is useful for systems that are susceptible to noise, power glitches and other conditions that can cause the software to go into infinite dead loops or runaways. The WDT function gives the user software a recovery mechanism from abnormal software conditions.

The Watch Dog Timer of the VRS550 and VRS560 devices is driven by the oscillator.

To enable the WDT, the user must set bit 7 (WDTE) of the WDTCON register to 1. Once WDTE has been set to 1, the 16-bit counter will start to count with the selected time base source clock configured in WDPS2~WDPS0. The Watch Dog Timer will generate a reset signal if an overflow has taken place.

The WDTE bit will be cleared to 0 automatically when the device is reset by either the hardware or a WDT reset.

Once the WDT is enabled, the user software must clear it periodically. In the case where the WDT is not cleared, its overflow will trigger a reset of the device.

The user should check the WDRESET bit of the SYSCON register whenever an unpredicted reset has taken place.

The WDT timeout delay can be adjusted by configuring the clock divider input for the time base source clock of the WDT. To select the divider value, bit2-bit0 (WDPS2~WDPS0) of the Watch Dog Timer Control Register (WDTCON) should be set accordingly.

Clearing the WDT is accomplished by setting the CLR bit of the WDTCON to 1. This action will clear the contents of the 16-bit counter and force it to restart.

Watch Dog Timer Registers

Three registers of the VRS550/VRS560 devices are associated with the Watch Dog Timer: WDTCON, the WDTLOCK and the SYSCON registers. The WDTCON register allows the user to enable the WDT, to clear the counter and to divide the clock source. The WDRESET bit of the SYSCON register indicates whether the Watch Dog Timer has caused the device reset.

TABLE 22: WATCHDOG TIMER REGISTERS: WDTCON – SFR 9FH

| | | | | | | | |
|------|--------|-------|--------|-------------|---|---|---|
| 7 | 6 | 5 | 4 | 3 | 2 | 1 | 0 |
| WDTE | Unused | WDCLR | Unused | WDTPS [2:0] | | | |

| Bit | Mnemonic | Description |
|-------|------------|-------------------------------------|
| 7 | WDTE | Watch Dog Timer Enable Bit |
| 6 | Unused | - |
| 5 | WDCLR | Watch Dog Timer Counter Clear Bit |
| [4:3] | Unused | - |
| 2 | WDPS [2:0] | Watchdog Timer Clock Source Divider |
| 1 | | |
| 0 | | |

The table below gives examples of Watchdog timeout period the user will obtain for different values of the WDPSx bits of the Watch Dog Timer Register.

TABLE 23: WATCH DOG TIMER PERIOD VS. WDWDPS [2:0] BIT

| WDPS [2:0] | Fosc Division Factor | WDT Timeout (ms) @ 20MHz |
|------------|----------------------|--------------------------|
| 000 | 8 | 26.2 |
| 001 | 16 | 52.4 |
| 010 | 32 | 104.8 |
| 011 | 64 | 209.7 |
| 100 | 128 | 419.4 |
| 101 | 256 | 838.8 |
| 110 | 512 | 1677.7 |
| 111 | 1024 | 3355.4 |

The System Control Register

The System Control register is used to monitor the status of the Watch Dog Timer and inhibit the address Latch Enable signal output.

TABLE 24: THE SYSTEM CONTROL REGISTER (SYSCON)–SFR BFH

| 7 | 6 | 5 | 4 | 3 | 2 | 1 | 0 |
|---------|--------|---|---|---|---|--------|------|
| WDRESET | Unused | | | | | XFRAME | ALEI |

| Bit | Mnemonic | Description |
|-------|----------|---|
| 7 | WDRESET | Watch Dog Timer Reset Status Bit |
| [6:3] | Unused | - |
| 2 | Unused | - |
| 1 | Unused | - |
| 0 | ALEI | 1: Enable Electromagnetic Interference Reducer 0: Disable Electromagnetic Interference Reducer |

The WDRESET bit of the SYSCON register is the Watch Dog Timer Reset bit. It will be set to 1 when a reset signal is generated by the WDT overflow. The user should check the WDRESET bit state if a reset has taken place in application where the Watch Dog timer is activated

Reduced EMI Function

The VRS550 and the VRS560 devices can also be set up to reduce its EMI (electromagnetic interference) by setting bit 0 (ALEI) of the SYSCON register to 1. This function will inhibit the Fosc/6Hz clock signal output to the ALE pin.

Crystal Consideration

The crystal connected to the VRS550 / VRS560 oscillator input should be of a parallel type, operating in fundamental mode.

The following table shows the value of capacitors and feedback resistor that must be used at different operating frequencies.

| XTAL | 3MHz | 6MHz | 12MHz | 16MHz | 25MHz |
|------|-------|-------|-------|-------|-------|
| C1 | 30 pF | 30 pF | 30 pF | 30 pF | 15 pF |
| C2 | 30 pF | 30 pF | 30 pF | 30 pF | 15 pF |
| R | open | open | open | open | 62KΩ |

Note: Oscillator circuits may differ with different crystals or ceramic resonators in higher oscillation frequency.

Crystals or ceramic resonator characteristics vary from one manufacturer to the other.

The user should check the specific crystal or ceramic resonator technical literature available or contact the manufacturer to select the appropriate values for the external components.

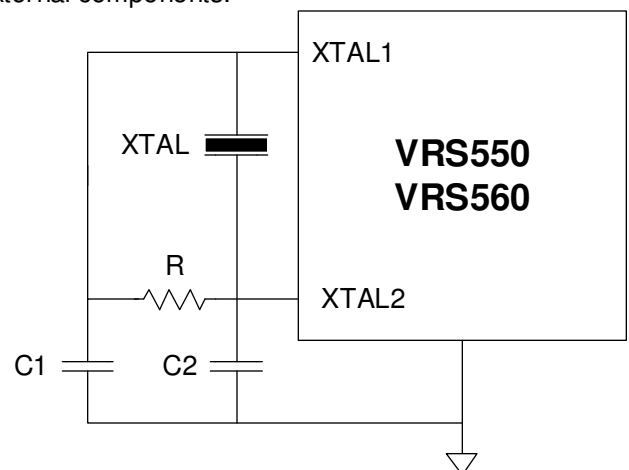

Operating Conditions

TABLE 25: OPERATING CONDITIONS

| Symbol | Description | Min. | Typ. | Max. | Unit | Remarks |
|---------|-----------------------|------|------|------|------|-------------------------------|
| TA | Operating temperature | -40 | 25 | 85 | °C | Ambient temperature operating |
| TS | Storage temperature | -55 | 25 | 155 | °C | |
| VCC5V | Supply voltage | 4.5 | 5.0 | 5.5 | V | 5 Volts devices |
| VCC3V | Supply voltage | 3.0 | 3.3 | 3.6 | V | 3.3 Volts devices |
| Fosc 25 | Oscillator Frequency | 3.0 | 25 | 25 | MHz | For 5V & 3.3V application |

DC Characteristics

TABLE 26: DC CHARACTERISTICS

AMBIENT TEMPERATURE = -40°C TO 85°C, 3.0V TO 5.5V

| Symbol | Parameter | Valid | Min. | Max. | Unit | Test Conditions |
|-----------------|----------------------------|------------------------|---------|---------|------|-----------------------|
| VIL1 | Input Low Voltage | Port 0,1,2,3,4,#EA | -0.5 | 0.8 | V | |
| VIL2 | Input Low Voltage | RES, XTAL1 | 0 | 0.8 | V | |
| VIH1 | Input High Voltage | Port 0,1,2,3,4,#EA | 2.0 | VCC+0.5 | V | |
| VIH2 | Input High Voltage | RES, XTAL1 | 70% VCC | VCC+0.5 | V | |
| VOL1 | Output Low Voltage | Port 0, ALE, #PSEN | | 0.45 | V | IOL=3.2mA |
| VOL2 | Output Low Voltage | Port 1,2,3,4 | | 0.45 | V | IOL=1.6mA |
| VOH1 | Output High Voltage | Port 0 | 2.4 | | V | IOH=-800uA (Vcc = 5V) |
| | | | 90% VCC | | V | IOH=-80uA |
| VOH2 | Output High Voltage | Port 1,2,3,4,ALE,#PSEN | 2.4 | | V | IOH=-60uA (Vcc = 5V) |
| | | | 90% VCC | | V | IOH=-10uA |
| IIL | Logical 0 Input Current | Port 1,2,3,4 | | -75 | uA | Vin=0.45V |
| ITL | Logical Transition Current | Port 1,2,3,4 | | -650 | uA | Vin=2.0V |
| ILI | Input Leakage Current | Port 0, #EA | | ±10 | uA | 0.45V < Vin < VCC |
| R RES | Reset Pull-down Resistance | RES | 50 | 300 | Kohm | |
| C ₁₀ | Pin Capacitance | | | 10 | pF | Freq=1 MHz, Ta=25°C |
| ICC | Power Supply Current | VDD | | | | |
| | | | 15 | | mA | Active mode 25MHz |
| | | | 10 | | mA | Active mode 16MHz |
| | | | 7.5 | | mA | Idle mode 25MHz |
| | | | 6 | | mA | Idle mode, 16MHz |
| | | | 150 | | uA | Power down mode |

FIGURE 22: ICC IDLE MODE TEST CIRCUIT

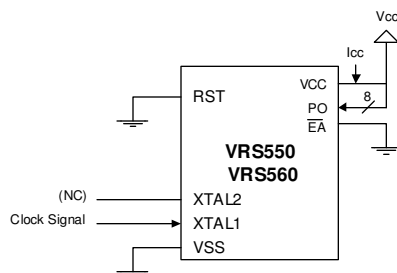
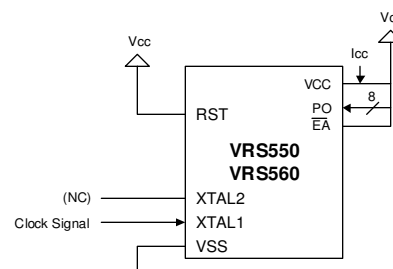

FIGURE 23: ICC ACTIVE MODE TEST CIRCUIT



AC Characteristics

TABLE 27: AC CHARACTERISTICS

| Symbol | Parameter | Valid Cycle | Fosc 16 | | | Variable Fosc | | | Unit |
|-----------|-----------------------------------|-------------|---------|------|------|---------------|--------|----------|------|
| | | | Min. | Type | Max. | Min. | Type | Max. | |
| T LHLL | ALE Pulse Width | RD/WRT | 115 | | | 2xT - 10 | | | nS |
| T AVLL | Address Valid to ALE Low | RD/WRT | 43 | | | T - 20 | | | nS |
| T LLAX | Address Hold after ALE Low | RD/WRT | 53 | | | T - 10 | | | nS |
| T LLIV | ALE Low to Valid Instruction In | RD | | | 240 | | | 4xT - 10 | nS |
| T LLPL | ALE Low to #PSEN low | RD | 53 | | | T - 10 | | | nS |
| T PLPH | #PSEN Pulse Width | RD | 173 | | | 3xT - 15 | | | nS |
| T PLIV | #PSEN Low to Valid Instruction In | RD | | | 177 | | | 3xT - 10 | nS |
| T PXIX | Instruction Hold after #PSEN | RD | 0 | | | 0 | | | nS |
| T PXIZ | Instruction Float after #PSEN | RD | | | 87 | | | T + 25 | nS |
| T AVI V | Address to Valid Instruction In | RD | | | 292 | | | 5xT - 20 | nS |
| T PLAZ | #PSEN Low to Address Float | RD | | | 10 | | | 10 | nS |
| T RLRH | #RD Pulse Width | RD | 365 | | | 6xT - 10 | | | nS |
| T WLWH | #WR Pulse Width | WRT | 365 | | | 6xT - 10 | | | nS |
| T RLDV | #RD Low to Valid Data In | RD | | | 302 | | | 5xT - 10 | nS |
| T RHDV | Data Hold after #RD | RD | 0 | | | 0 | | | nS |
| T RHDZ | Data Float after #RD | RD | | | 145 | | | 2xT + 20 | nS |
| T LLDV | ALE Low to Valid Data In | RD | | | 590 | | | 8xT - 10 | nS |
| T AVDV | Address to Valid Data In | RD | | | 542 | | | 9xT - 20 | nS |
| T LLYL | ALE low to #WR High or #RD Low | RD/WRT | 178 | | 197 | 3xT - 10 | | 3xT + 10 | nS |
| T AVYL | Address Valid to #WR or #RD Low | RD/WRT | 230 | | | 4xT - 20 | | | nS |
| T QVWH | Data Valid to #WR High | WRT | 403 | | | 7xT - 35 | | | nS |
| T QVWX | Data Valid to #WR Transition | WRT | 38 | | | T - 25 | | | nS |
| T WHQX | Data Hold after #WR | WRT | 73 | | | T + 10 | | | nS |
| T RLAZ | #RD Low to Address Float | RD | | | | | | 5 | nS |
| T YALH | #W R or #RD High to ALE High | RD/WRT | 53 | | 72 | T - 10 | | T + 10 | nS |
| T CHCL | Clock Fall Time | | | | | | | | nS |
| T CLCX | Clock Low Time | | | | | | | | nS |
| T CLCH | Clock Rise Time | | | | | | | | nS |
| T CHCX | Clock High Time | | | | | | | | nS |
| T, T CLCL | Clock Period | | 63 | | | | 1/fosc | | nS |

Data Memory Read Cycle Timing

The following timing diagram shows what occurs at each signal during a Data Memory Read Cycle.

FIGURE 24: DATA MEMORY READ CYCLE TIMING

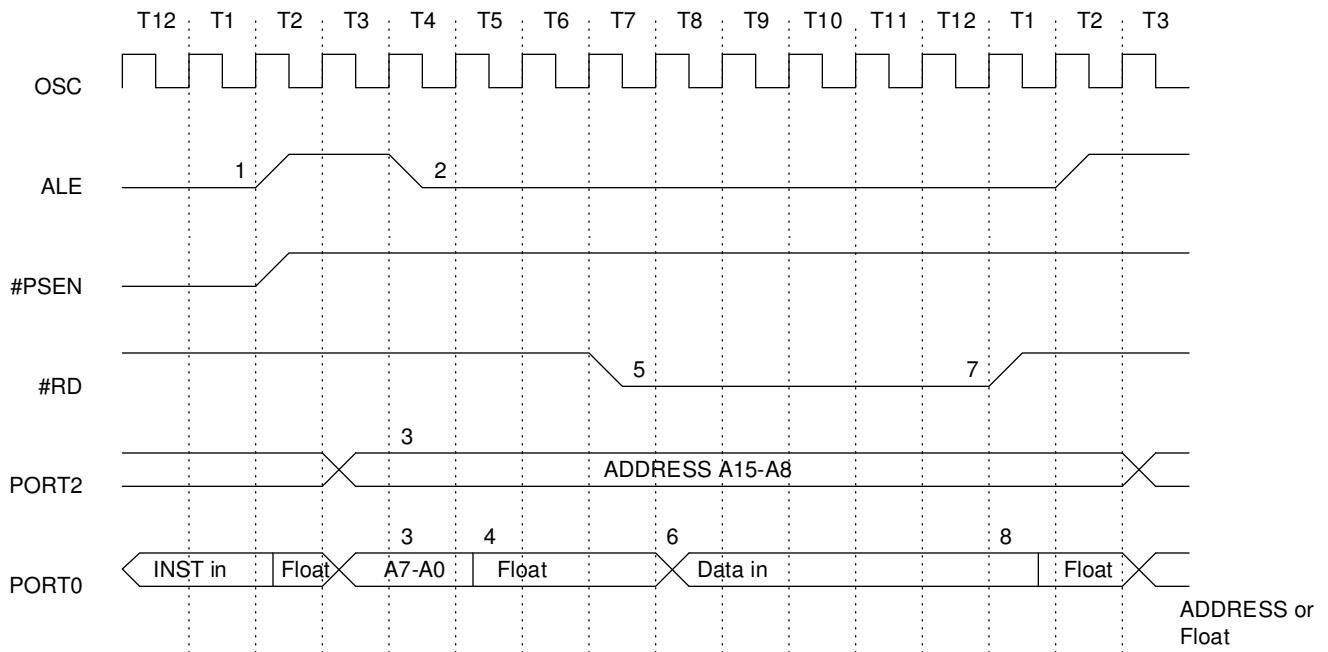

Program Memory Read Cycle Timing

The following timing diagram shows what occurs at each signal during a Program Memory Read Cycle.

FIGURE 25: PROGRAM MEMORY READ CYCLE

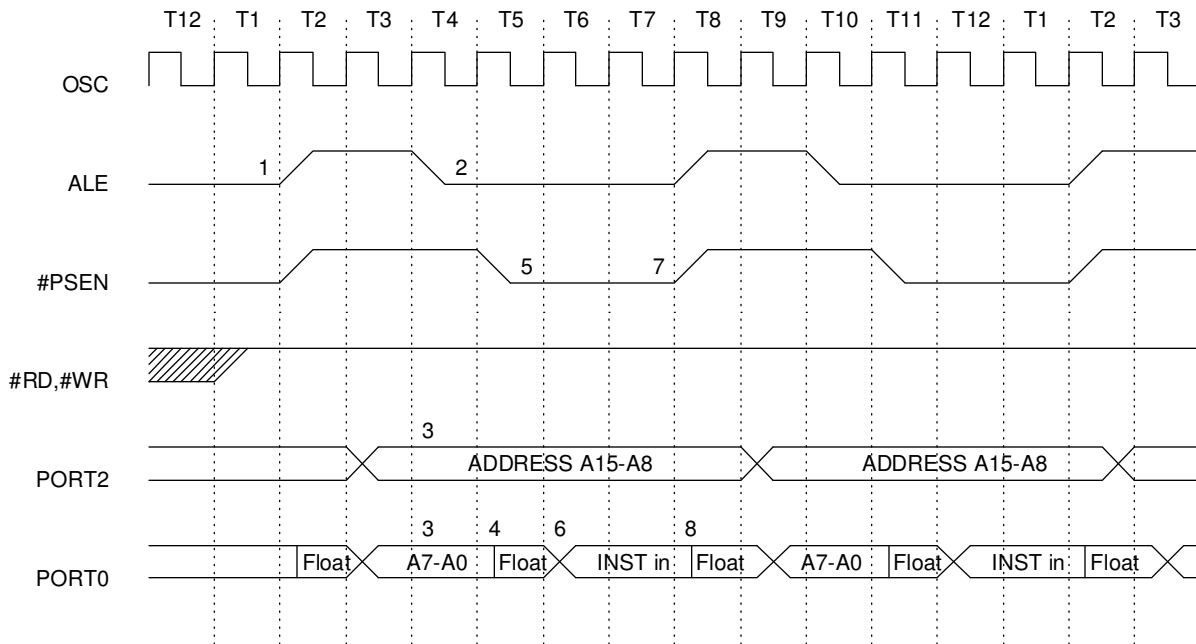

Data Memory Write Cycle Timing

The following timing diagram shows what occurs at each signal during a Data Memory Write Cycle.

FIGURE 26: DATA MEMORY WRITE CYCLE TIMING

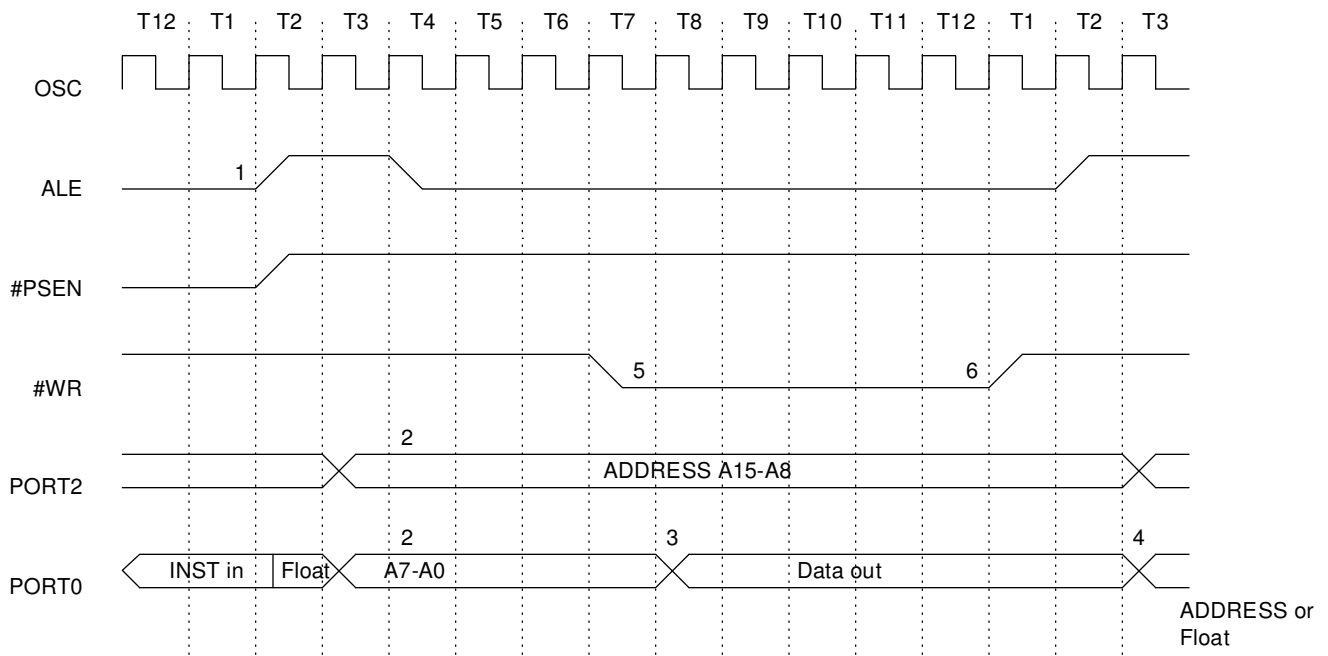

I/O Port Timing

The following timing diagram shows what occurs during I/O Port Timing.

FIGURE 27: I/O PORTS TIMING

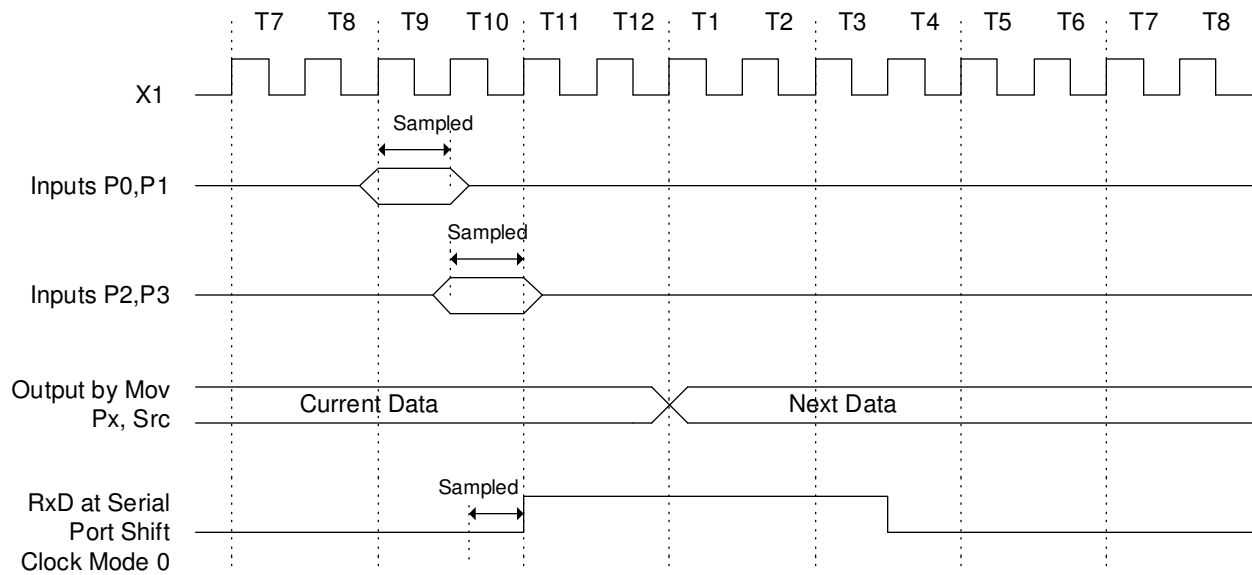

External Clock Timing

FIGURE 28: TIMING REQUIREMENT OF EXTERNAL CLOCK (VSS= 0.0V IS ASSUMED)

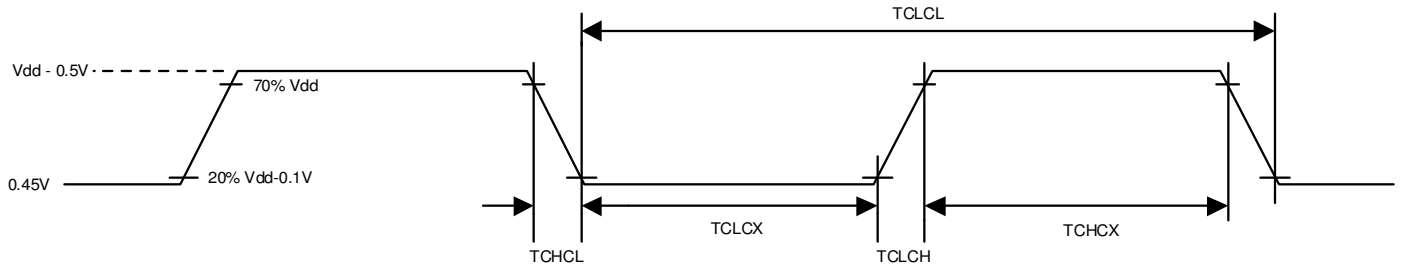

External Program Memory Read Cycle

The following timing diagram shows what occurs at each signal during an External Program Memory Read Cycle.

FIGURE 29: EXTERNAL PROGRAM MEMORY READ CYCLE

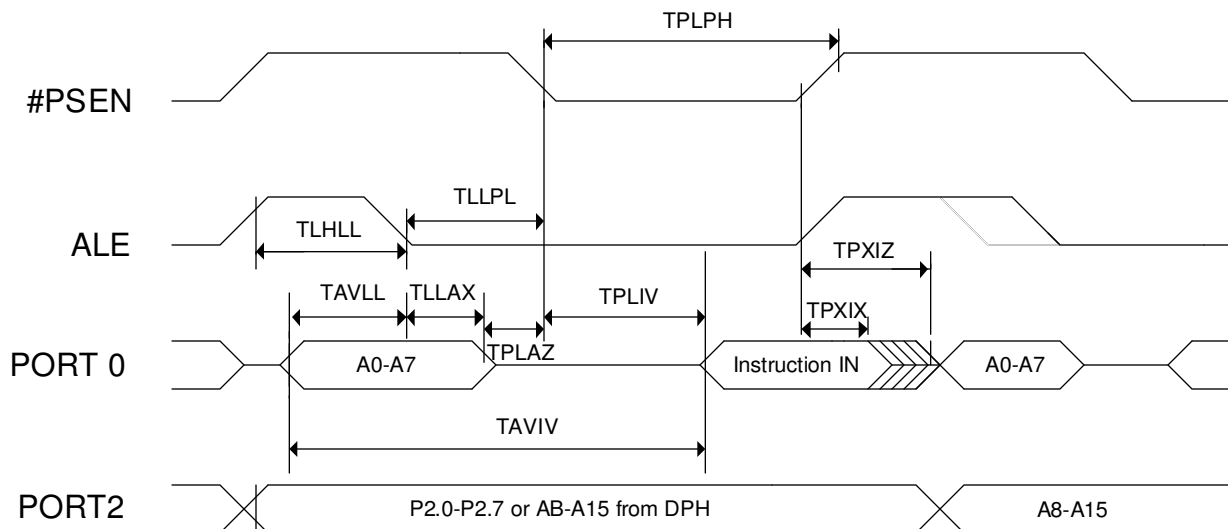

External Data Memory Read Cycle

The following timing diagram shows what occurs at each signal during an External Data Memory Read Cycle.

FIGURE 30: EXTERNAL DATA MEMORY READ CYCLE

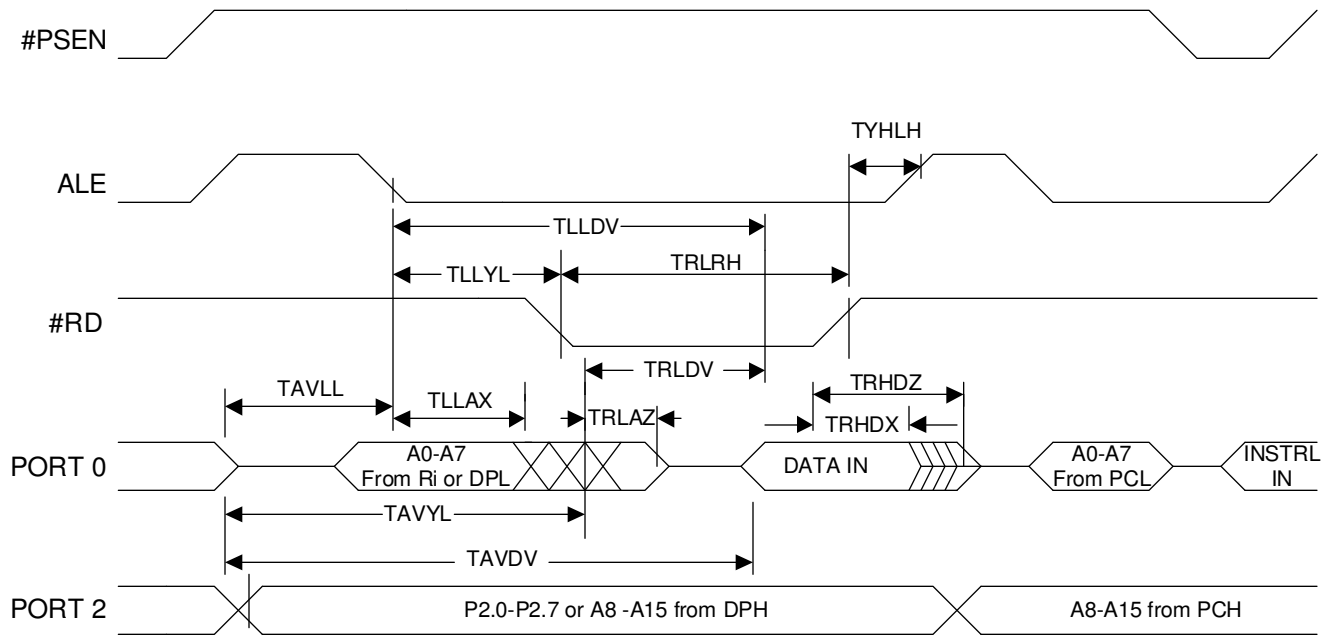

External Data Memory Write Cycle

The following timing diagram shows what occurs at each signal during an External Data Memory Write Cycle.

FIGURE 31: EXTERNAL DATA MEMORY WRITE CYCLE

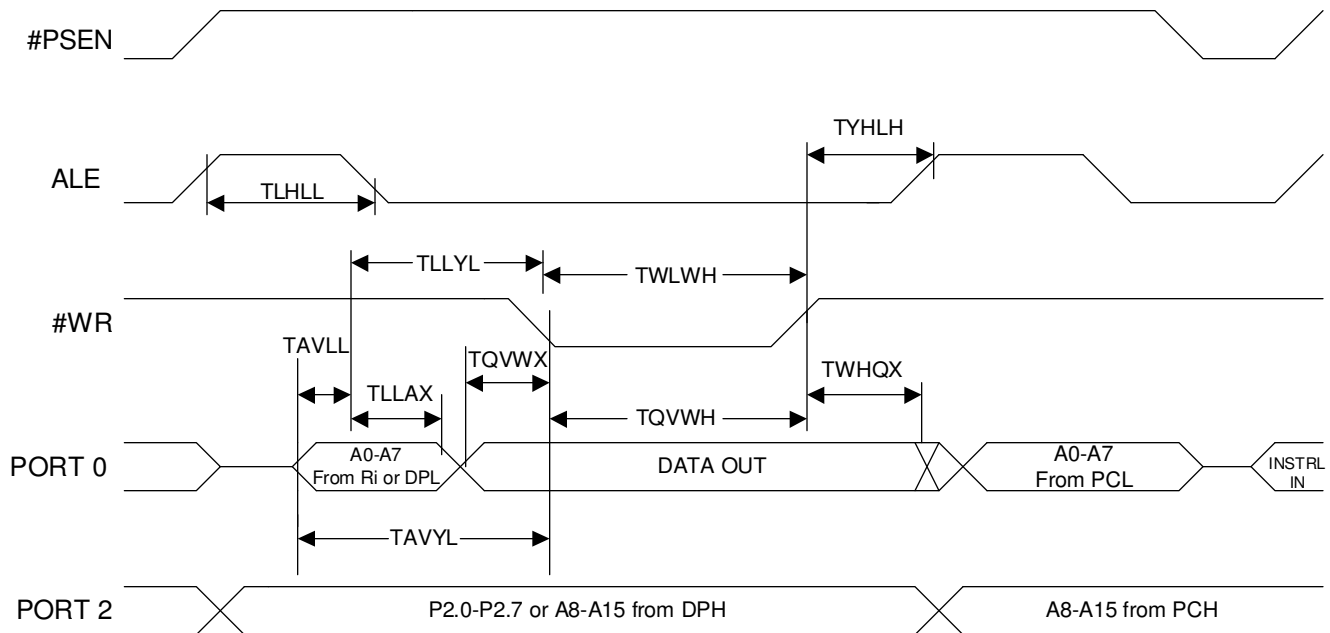

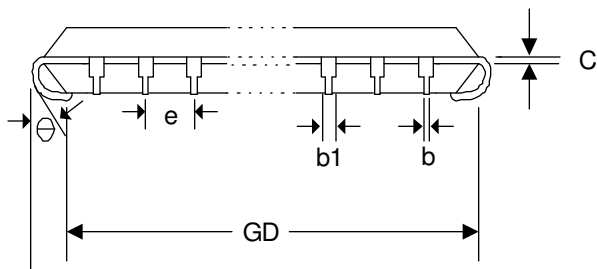
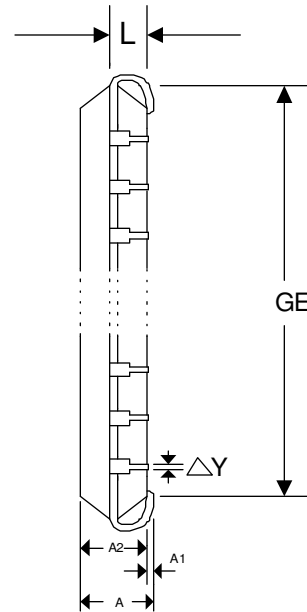
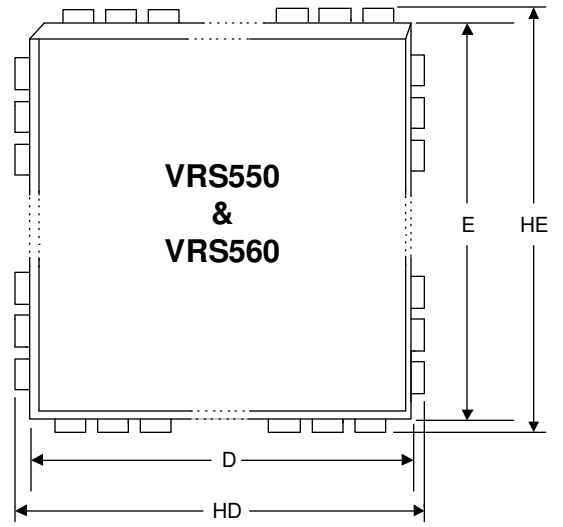
Plastic Chip Carrier (PLCC)

Note:

1. Dimensions D & E do not include interlead Flash.
2. Dimension B1 does not include dambar protrusion/intrusion.
3. Controlling dimension: Inch
4. General appearance spec should be based on final visual inspection spec.

TABLE 28: DIMENSIONS OF PLCC-44 CHIP CARRIER

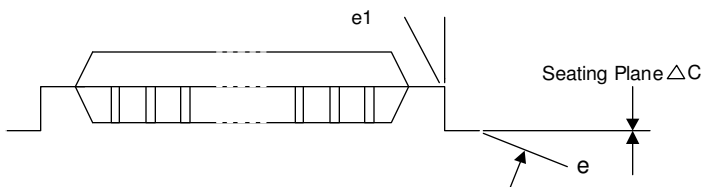
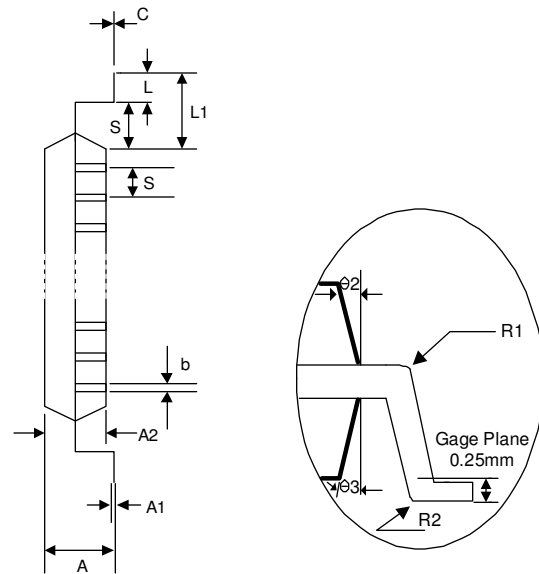
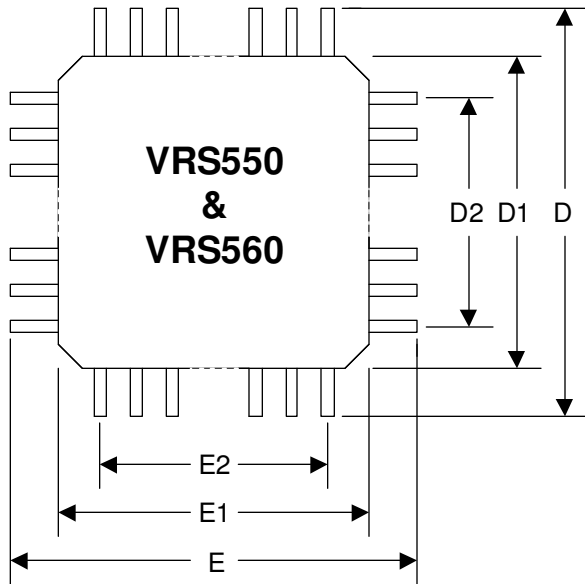
| Symbol | Dimension in inch | Dimension in mm |
|--------|-------------------|-----------------|
| | Minimal/Maximal | Minimal/Maximal |
| A | -/0.185 | -/4.70 |
| A1 | 0.020/- | 0.51/ |
| A2 | 0.145/0.155 | 3.68/3.94 |
| b1 | 0.026/0.032 | 0.66/0.81 |
| b | 0.016/0.022 | 0.41/0.56 |
| C | 0.008/0.014 | 0.20/0.36 |
| D | 0.648/0.658 | 16.46/16.71 |
| E | 0.648/0.658 | 16.46/16.71 |
| e | 0.050 BSC | 1.27 BSC |
| GD | 0.590/0.630 | 14.99/16.00 |
| GE | 0.590/0.630 | 14.99/16.00 |
| HD | 0.680/0.700 | 17.27/17.78 |
| HE | 0.680/0.700 | 17.27/17.78 |
| L | 0.090/0.110 | 2.29/2.79 |
| θ | -/0.004 | -/0.10 |
| Δy | / | / |

Quad Flat Package (QFP)

Note:

1. Dimensions D1 and E1 do not include mold protrusion.
2. Allowance protrusion is 0.25mm per side.
3. Dimensions D1 and E1 do not include mold mismatch and are determined datum plane.
4. Dimension b does not include dambar protrusion.
5. Allowance dambar protrusion shall be 0.08 mm total in excess of the b dimension at maximum material condition. Dambar cannot be located on the lower radius of the lead foot.

TABLE 29: DIMENSIONS OF QFP-44 CHIP CARRIER

| Symbol | Dimension in | |
|------------|-----------------|---------------------------------|
| | Minimal/Maximal | Dimension in mm Minimal/Maximal |
| A | -/0.100 | -/2.55 |
| A1 | 0.006/0.014 | 0.15/0.35 |
| A2 | 0.071 / 0.087 | 1.80/2.20 |
| b | 0.012/0.018 | 0.30/0.45 |
| c | 0.004 / 0.009 | 0.09/0.20 |
| D | 0.520 BSC | 13.20 BSC |
| D1 | 0.394 BSC | 10.00 BSC |
| D2 | 0.315 | 8.00 |
| E | 0.520 BSC | 13.20 BSC |
| E1 | 0.394 BSC | 10.00 BSC |
| E2 | 0.315 | 8.00 |
| e | 0.031 BSC | 0.80 BSC |
| L | 0.029 / 0.041 | 0.73/1.03 |
| L1 | 0.063 | 1.60 |
| R1 | 0.005/- | 0.13/- |
| R2 | 0.005/0.012 | 0.13/0.30 |
| S | 0.008/- | 0.20/- |
| θ | 0°/7° | as left |
| $\theta 1$ | 0°/ - | as left |
| $\theta 2$ | 10° REF | as left |
| $\theta 3$ | 7° REF | as left |
| ΔC | 0.004 | 0.10 |

Ordering Information

Device Number Structure

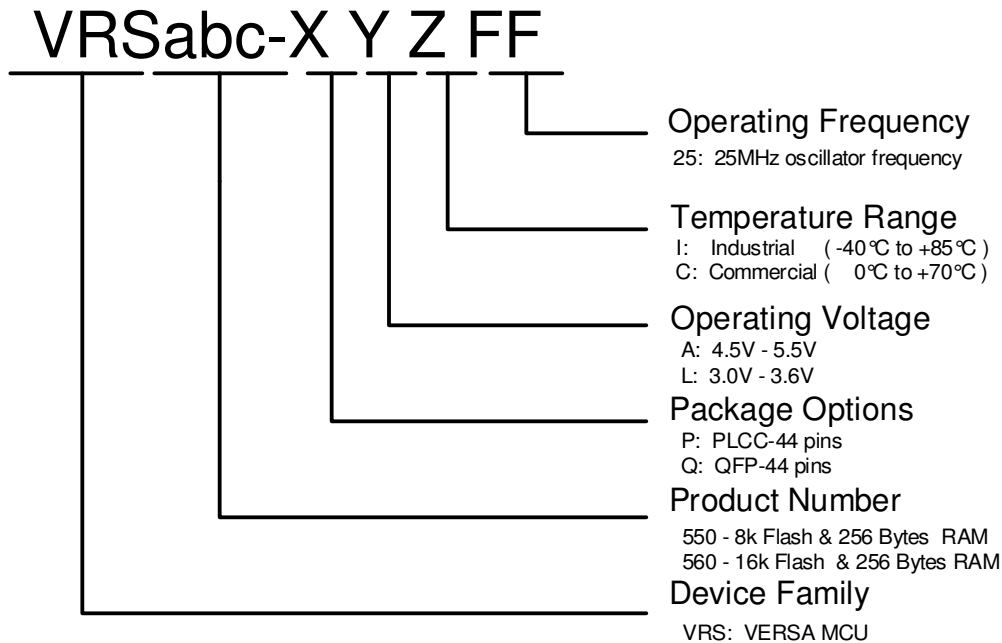

VRS550 Ordering Options

| Device Number | Flash Size | RAM Size | Package Option | Voltage | Temperature | Frequency |
|---------------|------------|-----------|----------------|--------------|----------------|-----------|
| VRS550-PAI25 | 8k | 256 Bytes | PLCC-44 | 4.5V to 5.5V | -40°C to +85°C | 25MHz |
| VRS550-PLI25 | 8k | 256 Bytes | PLCC-44 | 3.0V to 3.6V | -40°C to +85°C | 25MHz |
| VRS550-QAI25 | 8k | 256 Bytes | QFP-44 | 4.5V to 5.5V | -40°C to +85°C | 25MHz |
| VRS550-QLI25 | 8k | 256 Bytes | QFP-44 | 3.0V to 3.6V | -40°C to +85°C | 25MHz |

VRS560 Ordering Options

| Device Number | Flash Size | RAM Size | Package Option | Voltage | Temperature | Frequency |
|---------------|------------|-----------|----------------|--------------|----------------|-----------|
| VRS560-PAI25 | 16k | 256 Bytes | PLCC-44 | 4.5V to 5.5V | -40°C to +85°C | 25MHz |
| VRS560-PLI25 | 16k | 256 Bytes | PLCC-44 | 3.0V to 3.6V | -40°C to +85°C | 25MHz |
| VRS560-QAI25 | 16k | 256 Bytes | QFP-44 | 4.5V to 5.5V | -40°C to +85°C | 25MHz |
| VRS560-QLI25 | 16k | 256 Bytes | QFP-44 | 3.0V to 3.6V | -40°C to +85°C | 25MHz |

Disclaimers

Right to make change - Goal Semiconductor reserves the right to make changes to its products - including circuitry, software and services - without notice at any time. Customers should obtain the most current and relevant information before placing orders.

Use in applications - Goal Semiconductor assumes no responsibility or liability for the use of any of its products, and conveys no license or title under any patent, copyright or mask work right to these products and makes no representations or warranties that these products are free from patent, copyright or mask work right infringement unless otherwise specified. Customers are responsible for product design and applications using Goal Semiconductor parts. Goal Semiconductor assumes no liability for applications assistance or customer product design.

Life support - Goal Semiconductor products are not designed for use in life support systems or devices. Goal Semiconductor customers using or selling Goal products for use in such applications do so at their own risk and agree to fully indemnify Goal Semiconductor for any damages resulting from such applications.