

SWITCHED CAPACITOR MASK PROGRAMMABLE FILTER

- CHEBYCHEV TYPE
- 8TH ORDER
- STOPBAND ATTENUATION : 69dB (typ) AT $2 \times F_c$
- PASSBAND RIPPLE : 0.15dB (typ)
- CLOCK TO CUT-OFF FREQ; RATIO : 60
- CLOCK FREQUENCY RANGE : 1 TO 1500kHz
- CUT-OFF FREQUENCY RANGE : 16Hz TO 25kHz

Note : For general characteristics, see TSG85XX specifications. For non standard quality level, consult SGS-THOMSON general ordering information.

DESCRIPTION

The TSG8513 is a HCMOS lowpass polynomial filter.

PIN CONNECTIONS

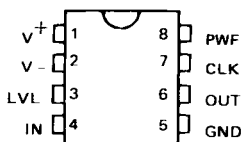
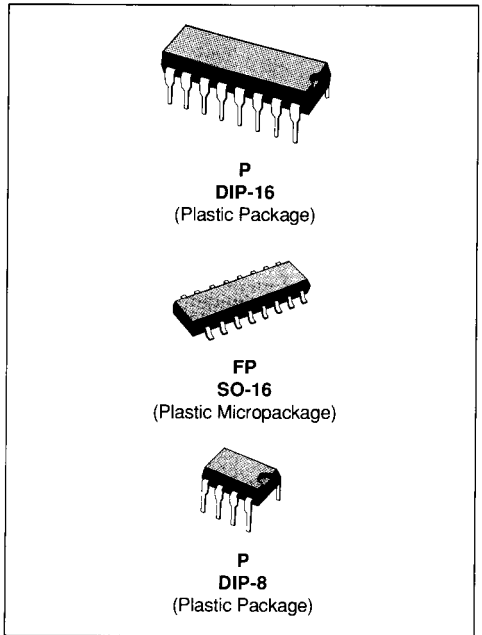

8 pins : FILTER ONLY
DIP-8 Package

E88TSG8513-01

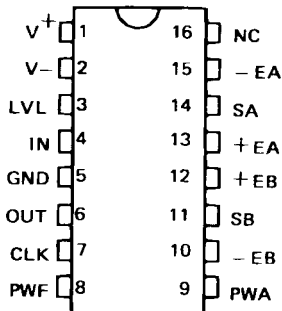

16 pins : FILTER + 2 OP-AMPS
DIP-16 Package

E88TSG8513-02

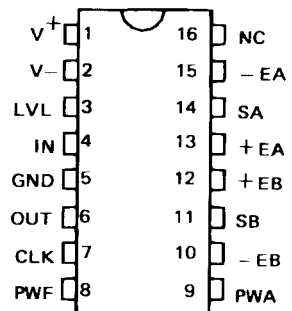

SO-16 Package

E88TSG8513-03

AMPLITUDE RESPONSE CURVE

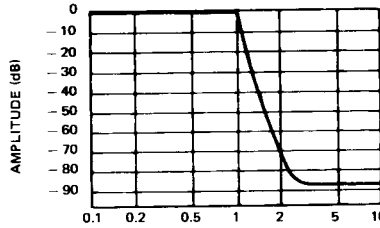

NORMALIZED FREQUENCY

E88TSG8513-04

FILTER SPECIFICATIONS

Lowpass Filter : TSG8513 ; Type : Chebychev ; Order : 8.
 $V^+ = 5V$, $V^- = -5V$, $T = 25^\circ C$, $R_L = 5k\Omega$, $C_L = 100pF$, $I_{PWF} = 100\mu A$

Symbol	Parameter		Typ.	Tested Limits	Unit
Fe	External Clock Frequency		1 1500(*)		kHz (min) kHz (max)
Fi	Internal Sampling Freq.		0.5 750(*)		kHz (min) kHz (max)
Fe/Fc	Clock to Cutoff fr. Ratio		60 ± 1%		
Fc	Cutoff Frequency		0.016 25(*)		kHz (min) kHz (max)
G _o	Passband Gain		- 0.3 0		dB (min) dB (max)
Ap	Passband Ripple	Fe = 60kHz	0.15	0.5	dB (max)
As	Stopband Attenuation	Fe = 60kHz F > 2Fc	69	65	dB (min)
Voff	Output DC Offset Voltage	LVL = 0V	± 100	± 250	mV (max)
LVL	DC Level Adjustment		± 100		mV (max)
LG	Level gain		- 2.5		
R _{PWF}	PWF Resistance		10 72		kΩ (min) kΩ (max)
I _{PWF}	Input Current on PWF		50 250		μA (min) μA (max)
I ⁺	V ⁺ Supply Current	Fe = 100kHz I _{pwa} = 0μA	3.8	5	mA (max)
I ⁻	V ⁻ Supply Current		3.8	5	mA (max)
PSRR ⁺	V ⁺ Supply Rejection Ratio	Fe = 120kHz Fin = 1kHz	25		dB
PSRR ⁻	V ⁻ Supply Rejection Ratio		40		dB
R _{IN}	Input Resistance		3		MΩ
C _{IN}	Input Capacitance		20		pF
Vo	Output Voltage Swing		+ 3.5 - 4.5		Vp-p (max)
Vn	Output Noise	BW = 1kHz Fe = 60kHz	107		μVrms
SNR	Signal to Noise Ratio	Vin = 2Vrms	85		dB

(*) At maximum Fe : - stopband attenuation As > 55dB for f > 2Fc
 (with I_{pwf} = 250μA) - passband ripple : A_p = 0.8dB
 - passband gain : G_o = - 0.6dB

PHASE RESPONSE CURVE (in passband)

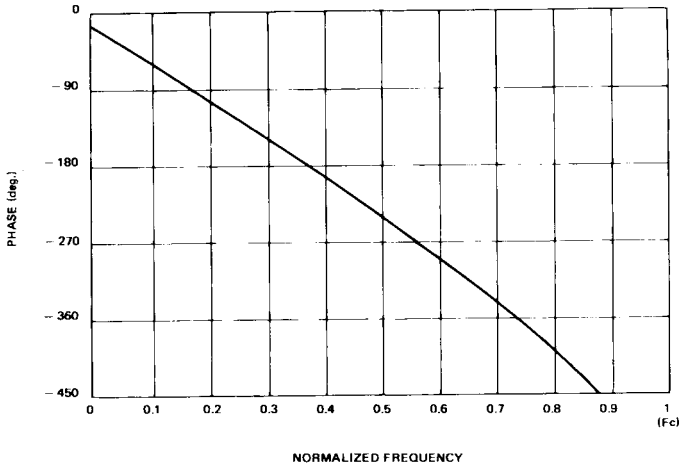

E88TSG8513-05

GROUP DELAY CURVE (in passband)

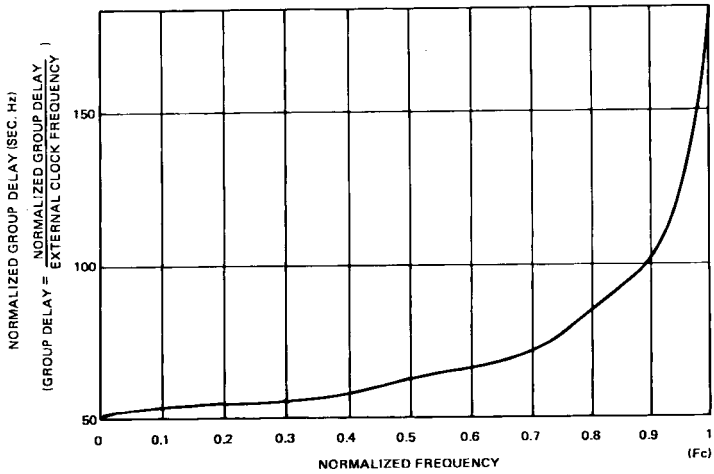

E88TSG8513-06

OUTPUT DC VOLTAGE ADJUSTMENT FROM LVL PIN

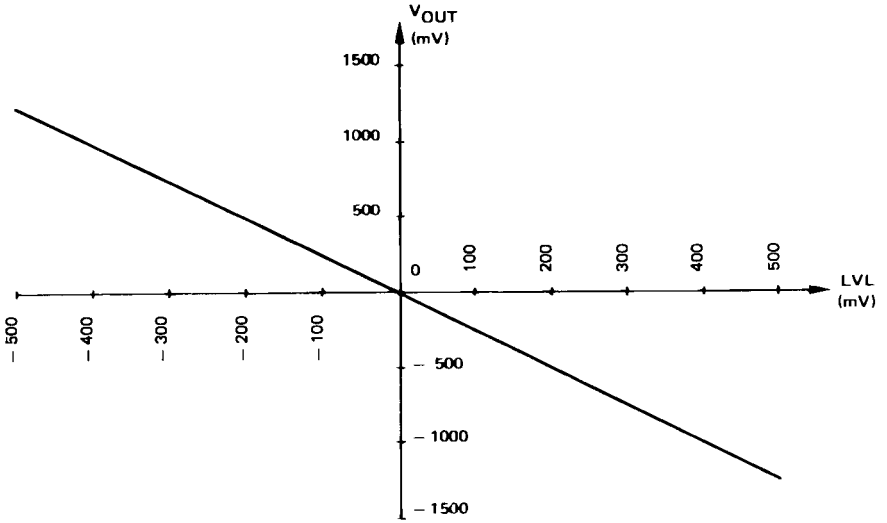

E88TSG8513-07

USER'S GUIDE FOR I_{PWF} AND R_{PWF} CHOICE

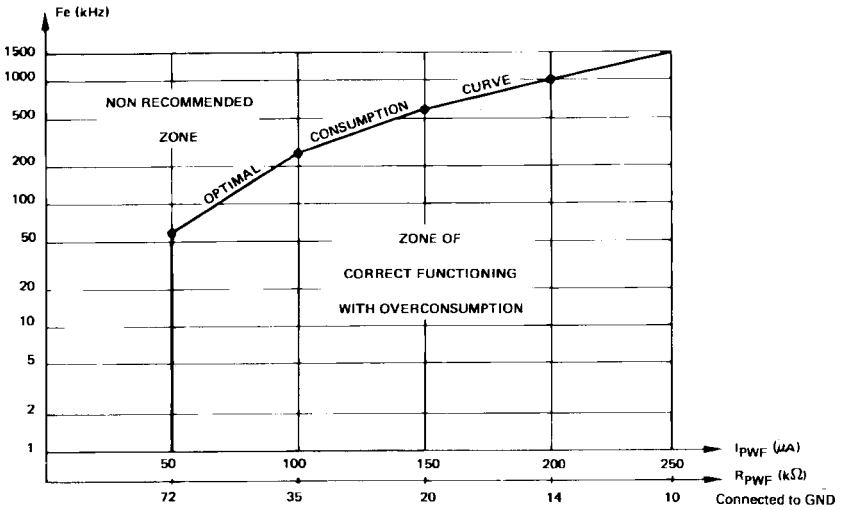

E88TSG8513-08

PACKAGE MECHANICAL DATA

16 PINS - Plastic Dip

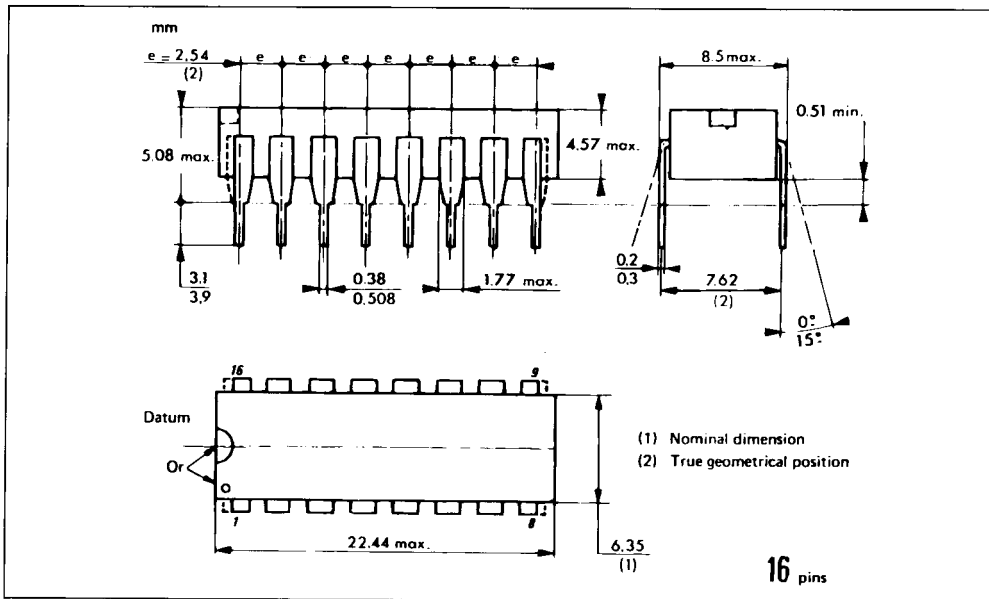

16 PINS - Plastic Micropackage

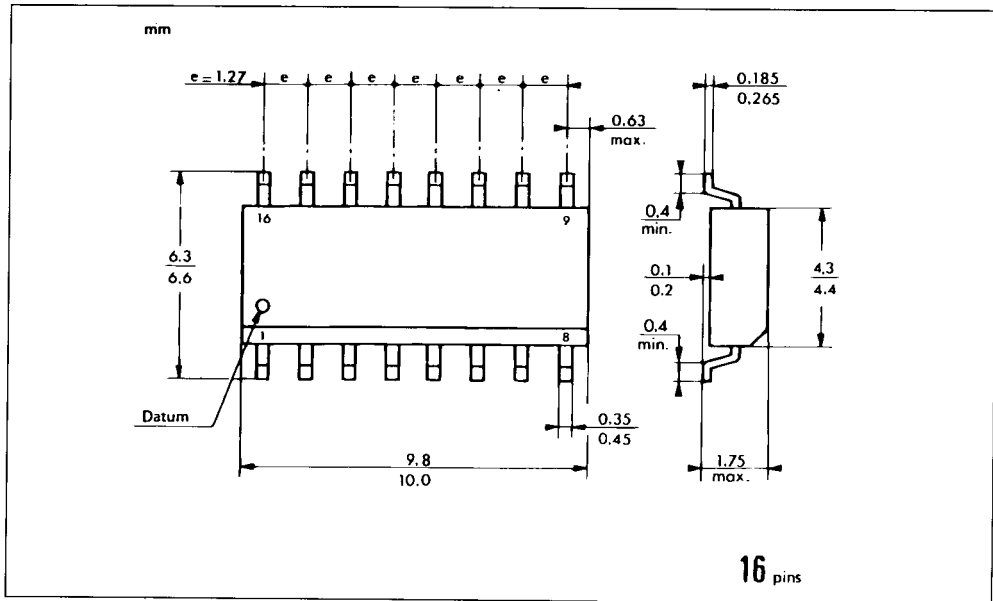

8 PINS - Plastic Dip

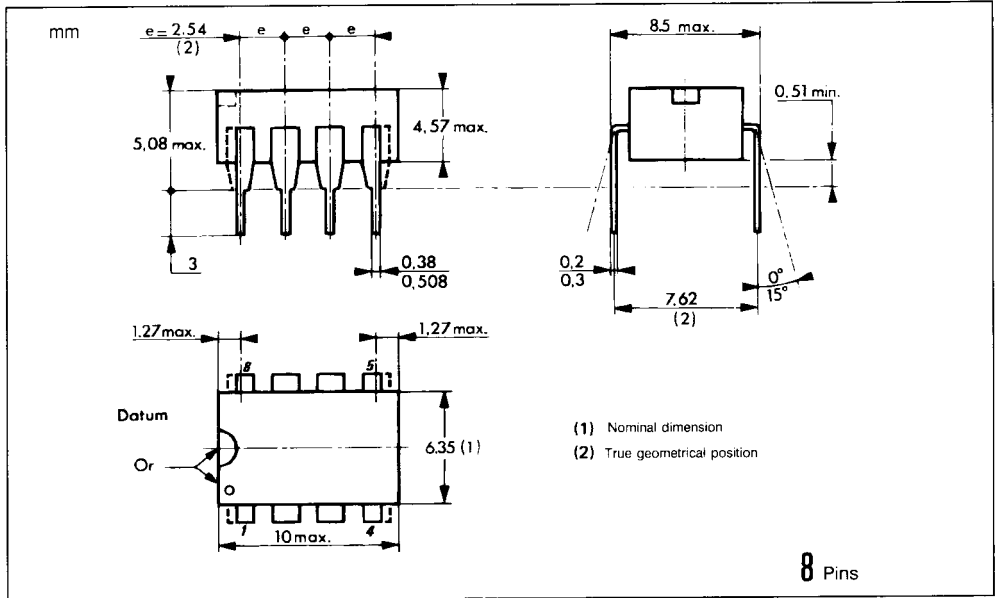

ORDER CODES

Plastic	16 Pins Package : TSG8513XP
Ceramic	16 Pins Package : TSG8513XC
Cerdip	16 Pins Package : TSG8513XJ
Plastic	8 Pins Package : TSG85131XP

X : Temperature Range = I : $0^\circ\text{C} + 70^\circ\text{C}$
 C : $-25^\circ\text{C} + 85^\circ\text{C}$
 V : $-40^\circ\text{C} + 85^\circ\text{C}$
 M : $-55^\circ\text{C} + 125^\circ\text{C}$

SO-8J

S G S-THOMSON

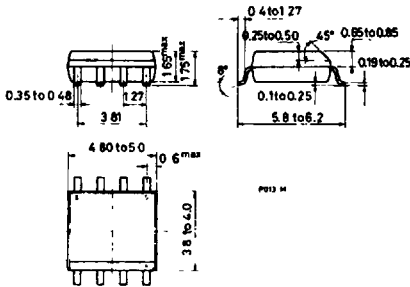
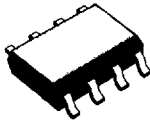

SO-14J

T-90-20

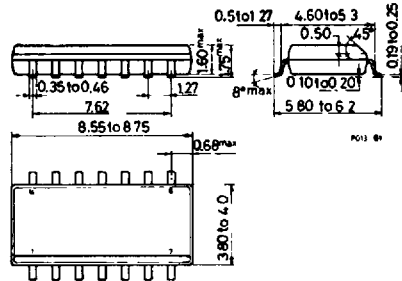
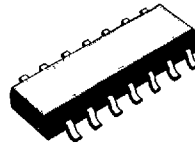

PLCC20

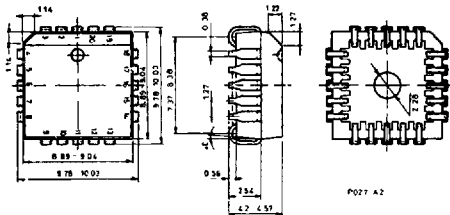
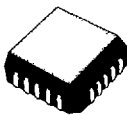

PLCC44

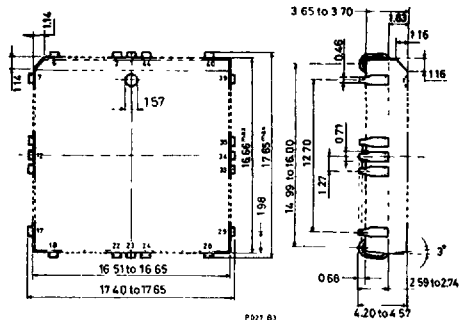
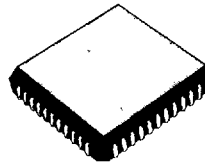

PACKAGES

S G S-THOMSON

PLCC-28 Plastic Chip Carrier

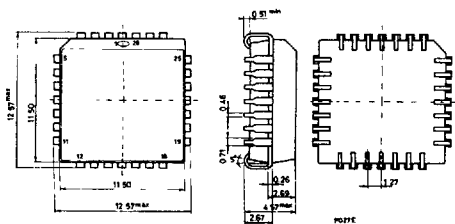
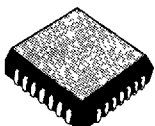

DIP-6

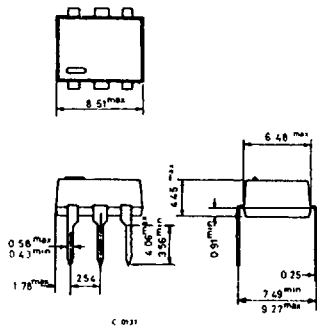

Minidip A Plastic

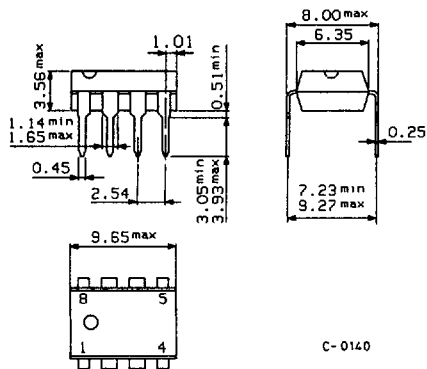
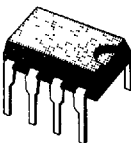

8 lead Plastic Minidip

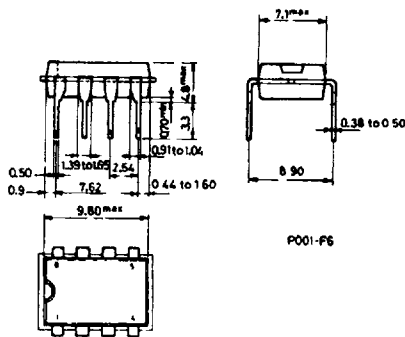
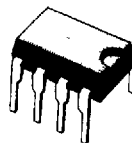

S G S-THOMSON

14 lead Ceramic Dip

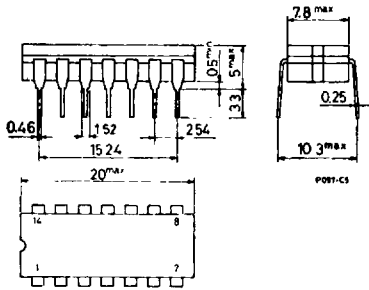
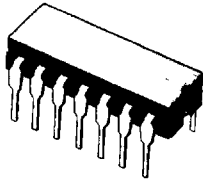

14 lead Plastic Dip

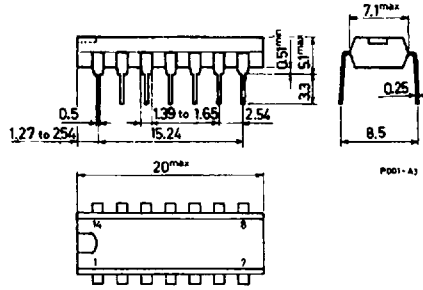
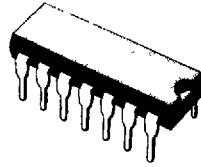

16 lead Ceramic Dip

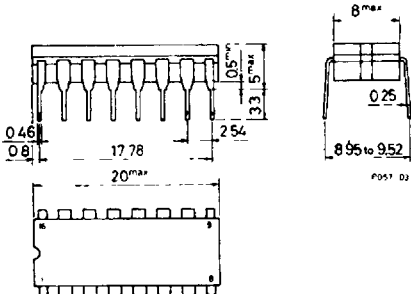
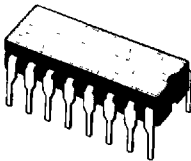

16 lead Plastic Dip (0.25)

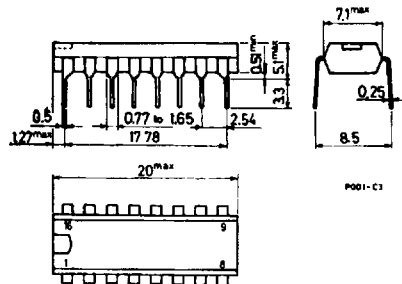
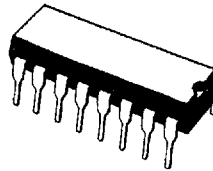

PACKAGES

S G S-THOMSON

DIP-20 Ceramic

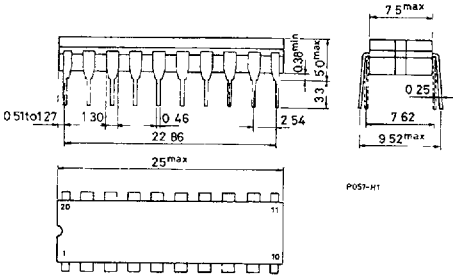
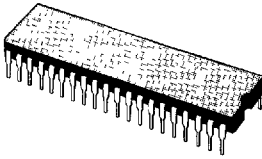

20 lead Plastic Dip (0.25)

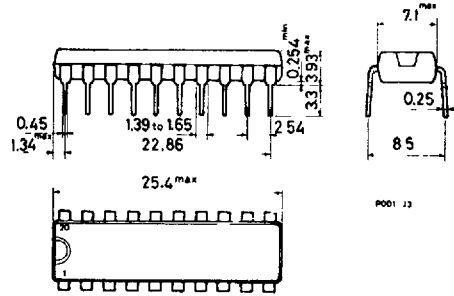
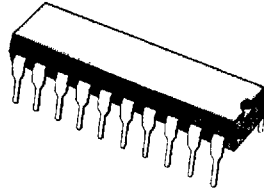

DIP-24 Plastic

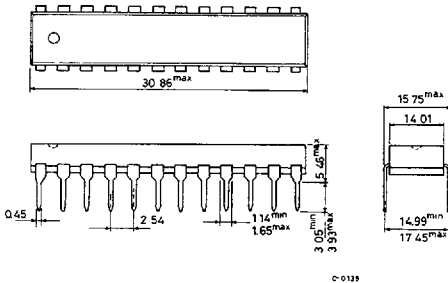
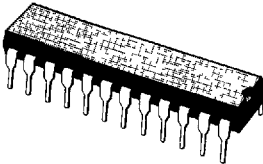

DIP-24 Ceramic (0.25)

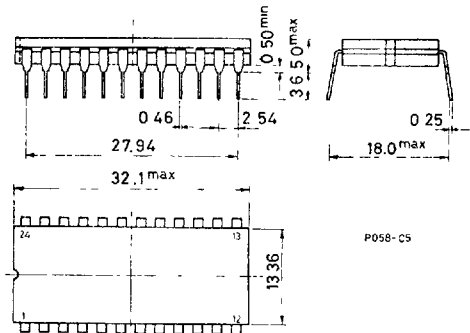
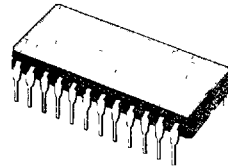

S G S-THOMSON

28 lead Plastic Dip

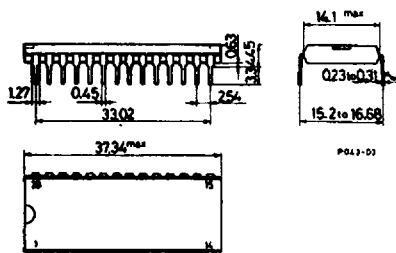
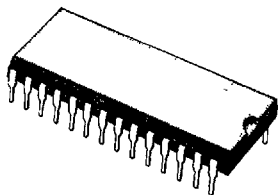

DIP-28 Ceramic (0.25)

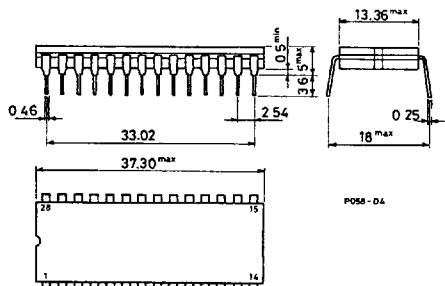
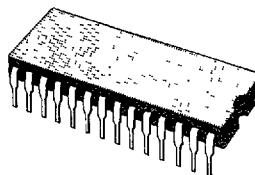

40 lead Plastic Dip

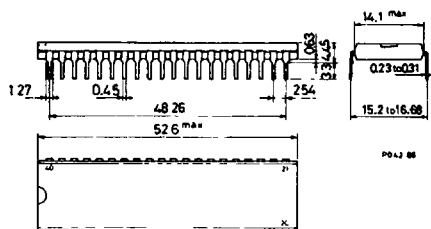
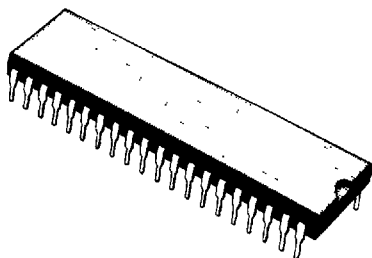

TO-99

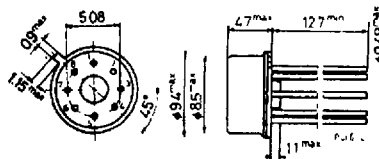
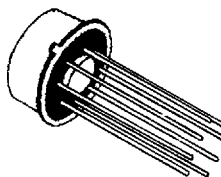

PACKAGES

S G S-THOMSON

MULTIWATT-15

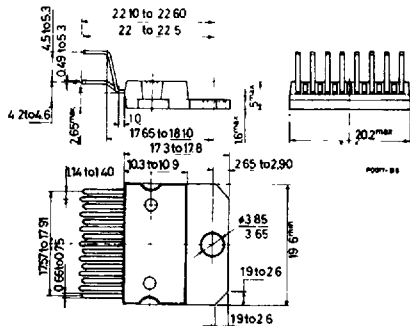
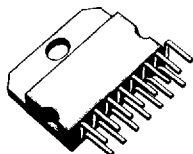

FLEXIWATT-15

