

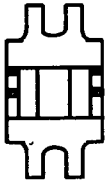

MwT-0618-102DG
6-18 GHz
MMIC AMPLIFIER MODULE

MICROWAVE TECHNOLOGY 4268 Solar Way Fremont, CA 94538 510-651-6700 FAX 510-651-2208



- 15.0 dB TYPICAL SMALL SIGNAL GAIN
- 1.9:1 TYPICAL VSWR
- 14 dBm TYPICAL P1dB
- ±0.75 dB TYPICAL OUTPUT POWER FLATNESS
- SINGLE SUPPLY BIAS
- CENTER FEED CONFIGURATION
- IDEAL FOR LIMITING AMPLIFIER APPLICATIONS

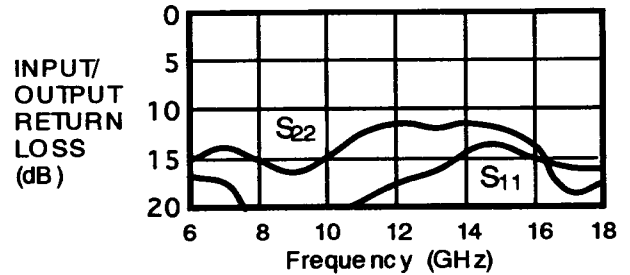
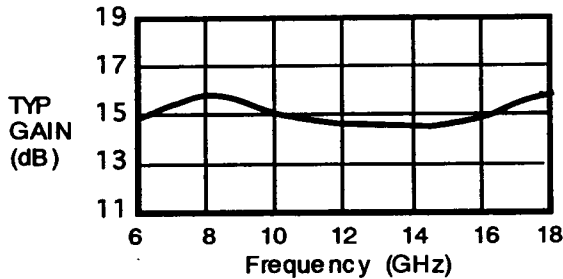

ELECTRICAL SPECIFICATIONS (Ta = 25°C, VDD = 8.0V, 6 - 18 GHz)

MwT-0618-102G-GFP (Model Number)

GAIN (dB)			GAIN FLATNESS (±dB)			P1dB (dBm)			IDD (mA)		
"G"	MIN	TYP	"F"	TYP	MAX	"P"	MIN	TYP	VDD	TYP	MAX
-3	13	14	-7	0.60	0.75	-0	9	10	8	80	90
-4	14	15	-1	0.75	1.00	-1	11	12	8	100	125
						-3	13	14	8	140	190
						-5	15	16	10	200	240

Example: MwT-0618-102DG -413 = 14 dB Gain, ±1.0 dB Gain Flatness, +13 dB m P1dB

SYMBOL	PARAMETERS	UNITS	MIN	TYP	MAX
FREQ	Frequency Range	GHz	6.0		18.0
VSWR, IN	Input VSWR	---		1.9:1	20:1
VSWR, OUT	Output VSWR	---		1.7:1	20:1
ΔG/ΔT	Gain Variation With Temperature	6 GHz 18 GHz		0.018 0.013	
NF	Noise Figure	dB		7.5	8.5
ISO	Reverse Isolation	dB		30	

NOTES:

1. Operating temperature range is -55 °C to +105 °C
2. Microwave Technology reserves the right to ship modules with gain and/or power above the typical specification of the model number.
3. All modules are serialized and shipped with data measured at 25 °C. Data includes swept small signal gain, swept input and output return loss, noise figure in 2 GHz increments, and P1dB in 2 GHz increments.
4. Test fixtures are available. Contact MwT for details.

MODULE OUTLINE

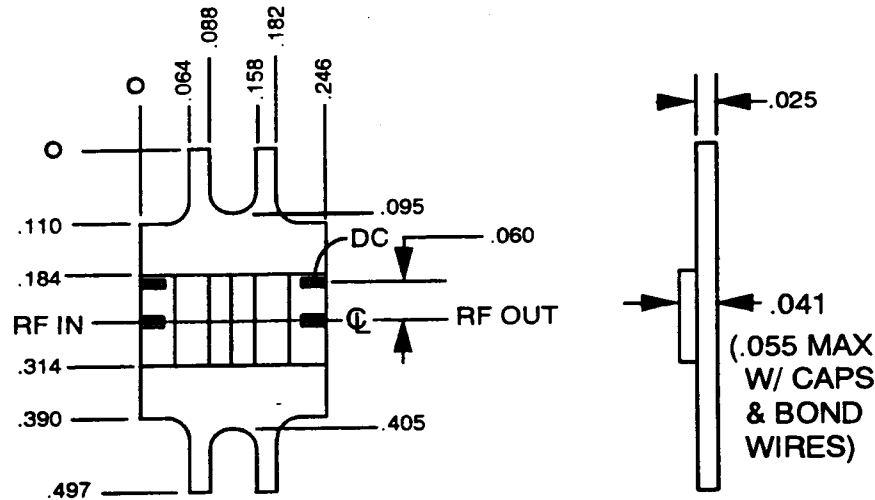

1. DIMENSIONS IN INCHES
2. TOLERANCE:
 XXX = +/- .005
 XX = +/- .01

CONSTRUCTION:

The 15 mil alumina substrates and 10 mil copper FET ridge are brazed onto the 25 mil Cu-W carrier using AuGe preform. The GaAs FETs (standard 5 mil thickness) are attached to the Cu ridge using AuSn preform. All capacitors are attached using AuSn preforms. The flanges are designed to accommodate 0-80 UNF-2A socket or Fillister head screws on .400 center-to-center hole spacing. The modules are mechanically and electrically designed to be cascaded.

NOTES:

1. Custom module specifications and/or custom module mechanical configurations are available.
2. OPERATING TEMPERATURE RANGE IS -55°C to +105°C.
3. All modules are serialized and shipped with data measured at 25°C. Data includes swept small signal gain, swept input and output return loss. Noise figure and P-1dB are measured in 1 GHz increments. Special module testing is available.
4. Test fixtures are available.
5. Microwave Technology reserves the right to ship modules with gain and/or power above the typical specifications.

4268 Solar Way Fremont, CA 94538 510-651-6700 FAX 510-651-2208

E/92

All rights reserved. MicroWave Technology, Inc. All specifications subject to change without notice.

2

JUL 0 7 1993

037581 ✓ - 12