

RWS-A-SERIES

Single output 15W ~ 450W

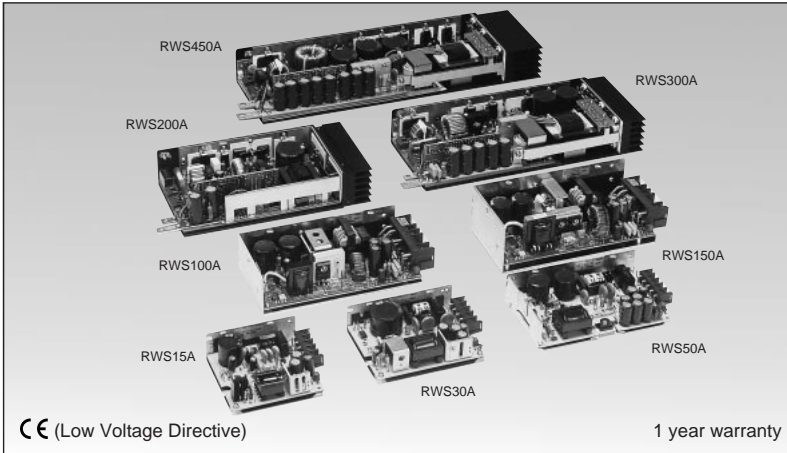

Model name

RWS 15A-5/

Name of series Output power Nominal output voltage Option
Blank: Open frame, Barrier strip terminal

Features

- CE marking (Low Voltage Directive)
- With PFHC
- Built-in RWS200A, 300A, 450A
- Low profile, 40 models
- Wide input voltage range
 - 85 ~ 265VAC universal input: RWS15A, 30A
 - 100/200VAC selectable: RWS50A, 100A, 150A
 - 85 ~ 265VAC universal input: RWS200A, 300A, 450A
- 1 year warranty

A: With cover, Barrier strip terminal
B: Open frame, Connector terminal (RWS15A, 30A, 50A only)
C: With cover, Connector terminal (RWS15A, 30A, 50A only)

Specifications

1. Input voltage range	RWS15A, 30A: 85 ~ 265VAC (47 ~ 440Hz), 110 ~ 330VDC universal input RWS50A, 100A, 150A: 85 ~ 132VAC/170 ~ 265VAC (47 ~ 440Hz), DC230 ~ 330V user selectable RWS200A, 300A, 450A: 85 ~ 265VAC (47 ~ 63Hz) universal input
2. Output voltage range	±10%
3. Cooling	Convection cooling
4. Operating ambient temperature (Standard mounting)	0 ~ +60°C RWS15A, 30A, 50A / 0 ~ +50°C: 100%, +60°C: 60% RWS100A, 150A / 0 ~ +50°C: 100%, +60°C: 50% -10 ~ +60°C RWS200A / -10 ~ +40°C: 100%, +50°C: 80%, +60°C: 60% RWS300A, 450A / -10 ~ +40°C: 100%, +50°C: 75%, +60°C: 50%
5. Withstand voltage	Input-output: 3kVAC, Input-FG: 2kVAC, Output-FG: 500VAC for 1 min.
6. Safety standard	Approved by UL1950 , CSA950 and EN60950
7. EMI	RWS15A, 30A, 50A: Conforms to FCC class B, RWS100A, 150A: Conforms to FCC class A
8. Functions	Over voltage protection, Over current protection, Remote sensing (RWS100A ~ 450A) Remote on/off control (RWS 200A ~ 450A)

● For 50 to 150W, We are to recommend JWS series (AC85 ~ 265V input, CE marking, PFHC, EMI, EMS) for new inquiries.

Product lineup

Model name		Nominal output voltage	Max. output current	Max. output power	UL	CSA	EN
RWS15A	RWS15A-5	5V	3.0A	15.0W	○	○	○
	RWS15A-12	12V	1.3A	15.6W	○	○	○
	RWS15A-15	15V	1.0A	15.0W	○	○	○
	RWS15A-24	24V	0.7A	16.8W	○	○	○
	RWS15A-48	48V	0.3A	14.4W	○	○	○
RWS30A	RWS30A-5	5V	6.0A	30.0W	○	○	○
	RWS30A-12	12V	2.5A	30.0W	○	○	○
	RWS30A-15	15V	2.0A	30.0W	○	○	○
	RWS30A-24	24V	1.3A	31.2W	○	○	○
RWS50A	RWS50A-5	5V	10.0A	50.0W	○	○	○
	RWS50A-12	12V	4.2A	50.4W	○	○	○
	RWS50A-15	15V	3.4A	51.0W	○	○	○
	RWS50A-24	24V	2.1A	50.4W	○	○	○
RWS100A	RWS100A-5	5V	20.0A	100.0W	○	○	○
	RWS100A-12	12V	8.5A	102.0W	○	○	○
	RWS100A-15	15V	7.0A	105.0W	○	○	○
	RWS100A-24	24V	4.5A	108.0W	○	○	○

Model name		Nominal output voltage	Max. output current	Max. output power	UL	CSA	EN
RWS150A	RWS150A-5	5V	30.0A	150.0W	○	○	○
	RWS150A-12	12V	13.0A	156.0W	○	○	○
	RWS150A-15	15V	10.0A	150.0W	○	○	○
	RWS150A-24	24V	6.5A	156.0W	○	○	○
	RWS150A-48	48V	3.2A	153.6W	○	○	○
RWS200A	RWS200A-3	3V	40A	120W	○	○	○
	RWS200A-5	5V	40A	200W	○	○	○
	RWS200A-12	12V	19A	228W	○	○	○
	RWS200A-15	15V	15A	225W	○	○	○
RWS300A	RWS300A-3	3V	60A	180W	○	○	○
	RWS300A-5	5V	60A	300W	○	○	○
	RWS300A-12	12V	26A	312W	○	○	○
	RWS300A-15	15V	21A	315W	○	○	○
RWS450A	RWS450A-3	3V	90A	270W	○	○	○
	RWS450A-5	5V	90A	450W	○	○	○
	RWS450A-12	12V	40A	480W	○	○	○
	RWS450A-15	15V	32A	480W	○	○	○

- Request customer specification for further details of specifications, outline, characteristics, etc. Read the instruction manual before usage.
- Contact us about delivery before ordering.

○ : Safety standard approved

RWS-A-SERIES

Unit Type Power Supply

RWS15A

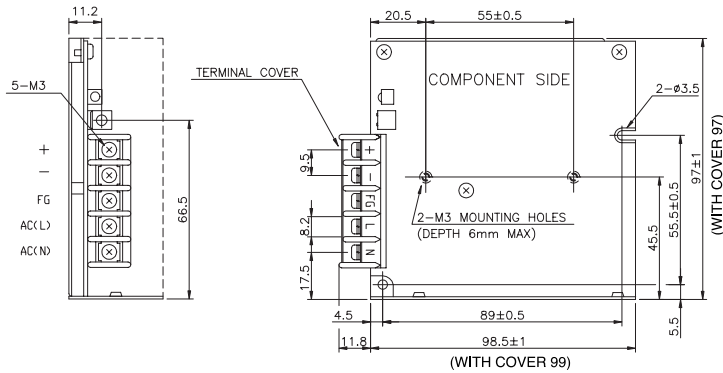

● Recommended Noise Filter

MAW-12R5-22



P134

● Recommended Power Supply Fixture



P198

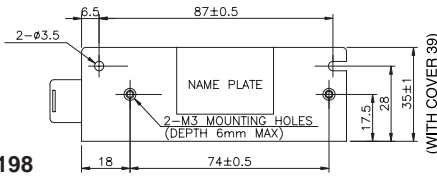

(Unit: mm)

RWS30A

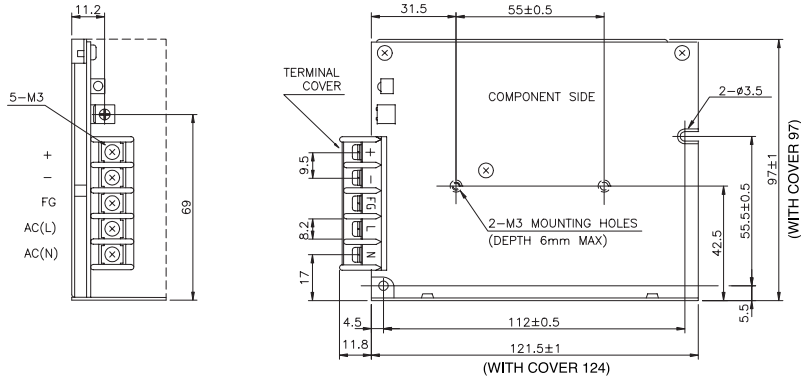

● Recommended Noise Filter

MAW-1201-22



P134

● Recommended Power Supply Fixture



P198

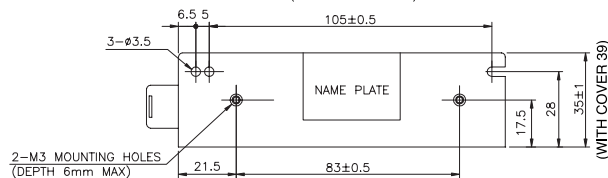

(Unit: mm)

RWS50A

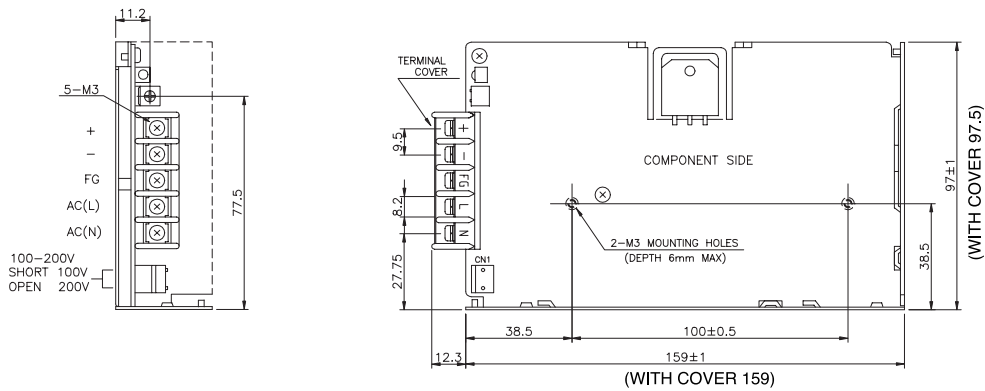

● Recommended Noise Filter

MAW-1202-22



P134

● Recommended Power Supply Fixture



P198

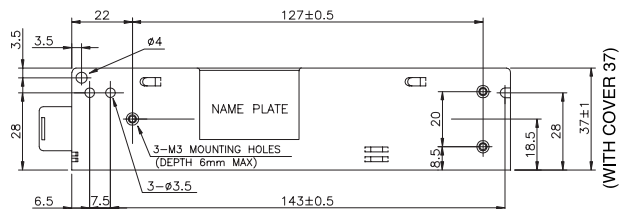

(Unit: mm)

RWS-A-SERIES

■ RWS100A

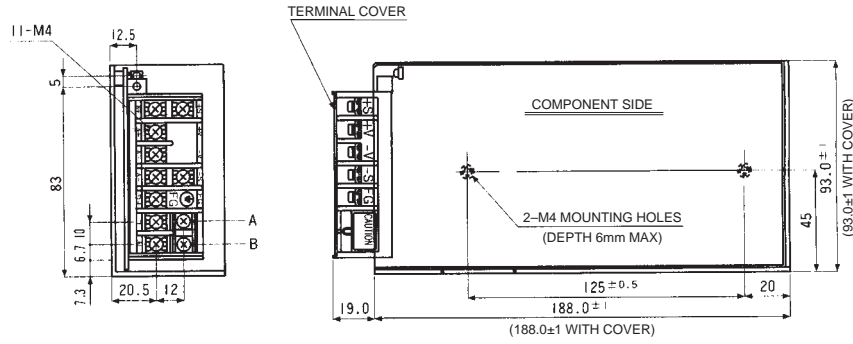

● Recommended Noise Filter

MB1206



P137

● Recommended Power Supply Fixture

P198

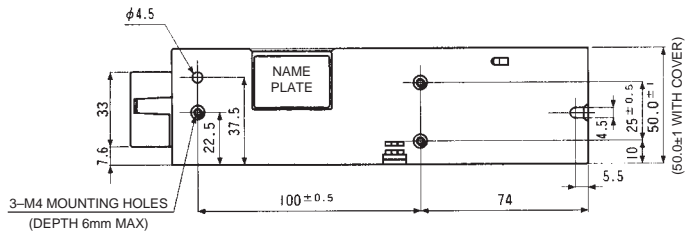

(Unit: mm)

■ RWS150A

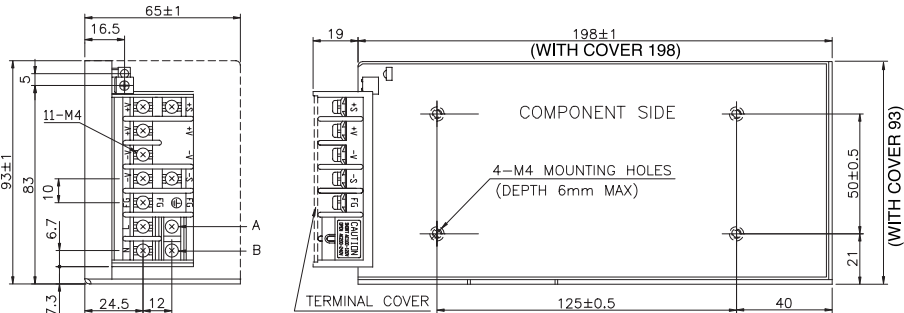

● Recommended Noise Filter

MB1206



P137

● Recommended Power Supply Fixture

P198

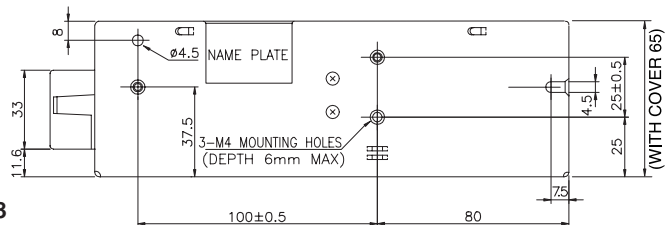

(Unit: mm)

■ RWS200A

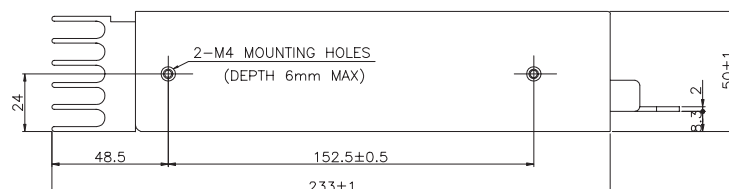
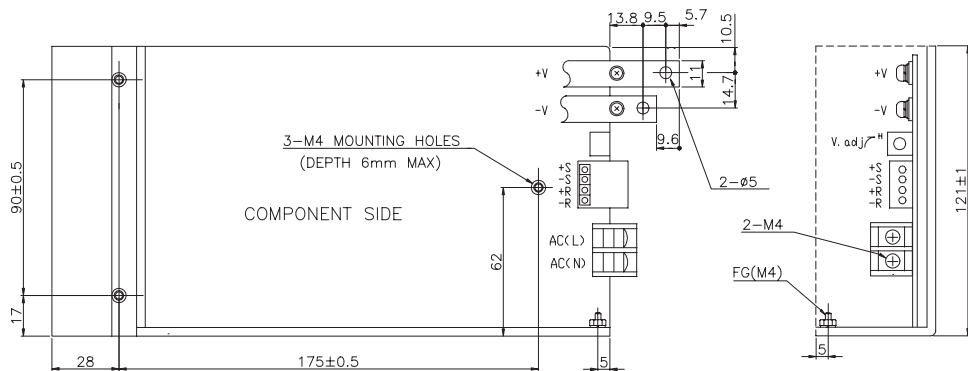

● Recommended Noise Filter

MXB-1206-33



P148

● Recommended Power Supply Fixture

P198

(Unit: mm)

RWS-A-SERIES

■ RWS300A

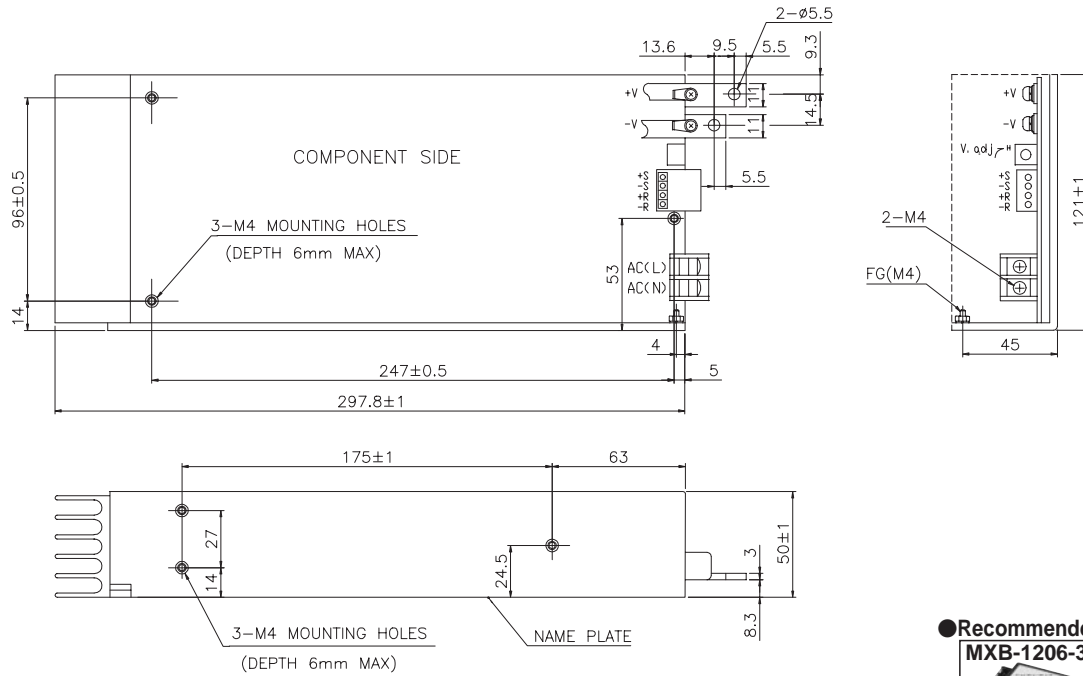

● Recommended Noise Filter

MXB-1206-33



P148

● Recommended Power Supply Fixture

P198

(Unit: mm)

■ RWS450A

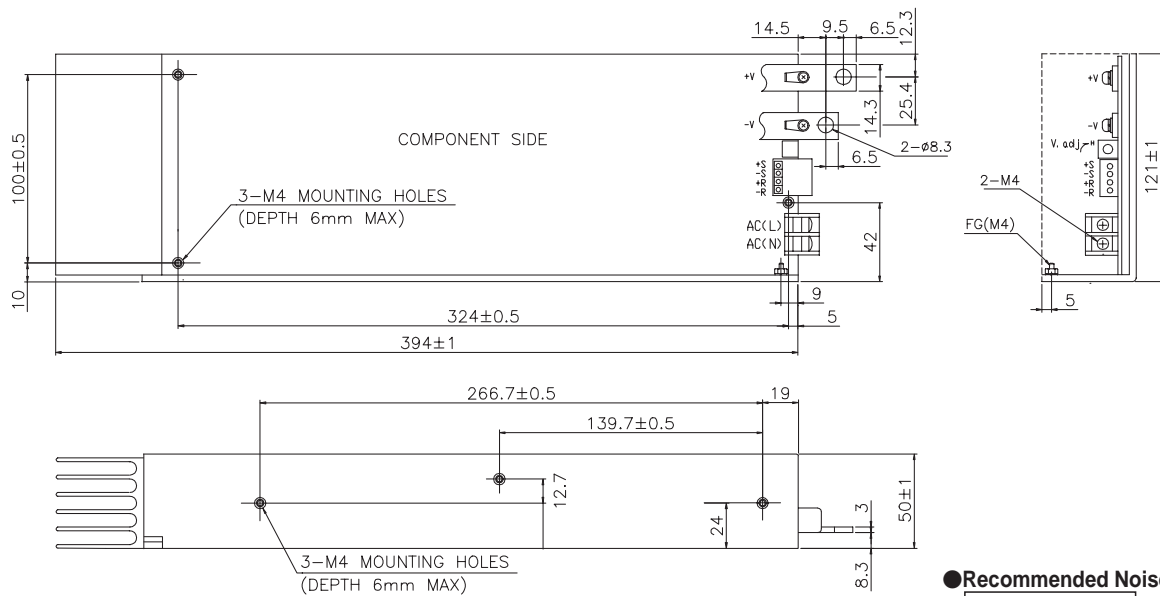

● Recommended Noise Filter

MXB-1210-33



P148

● Recommended Power Supply Fixture

P198

(Unit: mm)