



512 Kbit Serial I²C Bus EEPROM

FEATURES SUMMARY

- Two-Wire I²C Serial Interface
Supports 400 kHz Protocol
- Supply Voltage Ranges:
 - 1.8V to 5.5V (M24512 – R)
 - 2.5V to 5.5V (M24512 – W)
- Write Control Input
- BYTE and PAGE WRITE (up to 128 Bytes)
- RANDOM and SEQUENTIAL READ Modes
- Self-Timed Programming Cycle
- Automatic Address Incrementing
- Enhanced ESD/Latch-Up Protection
- More than 100,000 Erase/Write Cycles
- More than 40-Year Data Retention

Table 1. M24512 devices

Reference	Part Number
M24512	M24512 – W
	M24512 – R

Figure 1. Packages

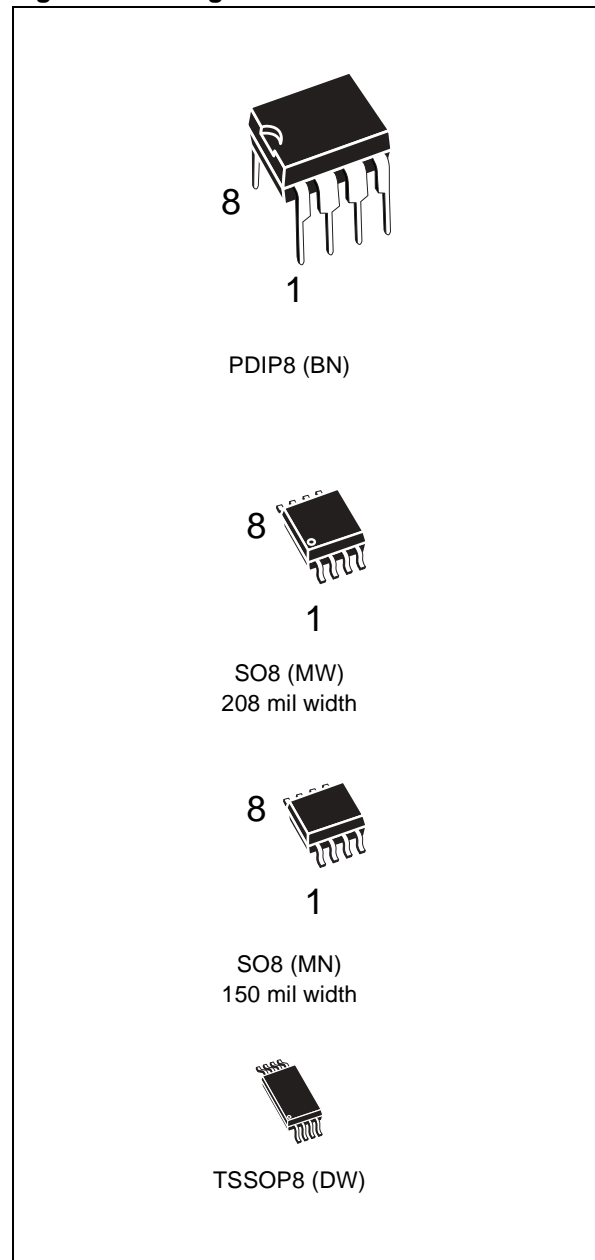

TABLE OF CONTENTS

FEATURES SUMMARY	1
Table 1. M24512 devices	1
Figure 1. Packages	1
Figure 2. Logic Diagram	4
Table 2. Signal Names	4
Power On Reset	4
Figure 3. DIP, SO and TSSOP Connections	4
SIGNAL DESCRIPTION	5
Serial Clock (SCL)	5
Serial Data (SDA)	5
Chip Enable (E0, E1, E2)	5
Write Control (\overline{WC})	5
Figure 4. Maximum R_p Value versus Bus Parasitic Capacitance (C) for an I ² C Bus	5
Figure 5. I ² C Bus Protocol	6
Table 3. Device Select Code	6
Table 4. Most Significant Byte	6
Table 5. Least Significant Byte	6
DEVICE OPERATION	7
Start Condition	7
Stop Condition	7
Acknowledge Bit (ACK)	7
Data Input	7
Memory Addressing	7
Table 6. Operating Modes	7
Figure 6. Write Mode Sequences with $\overline{WC}=1$ (data write inhibited)	8
Write Operations	8
Byte Write	8
Page Write	9
Figure 7. Write Mode Sequences with $\overline{WC}=0$ (data write enabled)	9
Figure 8. Write Cycle Polling Flowchart using ACK	10
Minimizing System Delays by Polling On ACK	10
Figure 9. Read Mode Sequences	11
Read Operations	11
Random Address Read	11
Current Address Read	11
Sequential Read	12
Acknowledge in Read Mode	12
INITIAL DELIVERY STATE	12
MAXIMUM RATING	13
Table 7. Absolute Maximum Ratings	13

DC AND AC PARAMETERS	14
Table 8. Operating Conditions (M24512 – W)	14
Table 9. Operating Conditions (M24512 – R)	14
Table 10. AC Measurement Conditions	14
Figure 10.AC Measurement I/O Waveform	14
Table 11. Input Parameters	15
Table 12. DC Characteristics (M24512 – W)	15
Table 13. DC Characteristics ⁽¹⁾ (M24512 – R)	15
Table 14. AC Characteristics (M24512 – W)	16
Table 15. AC Characteristics ⁽¹⁾ (M24512 – R)	16
Figure 11.AC Waveforms	17
PACKAGE MECHANICAL	18
Figure 12.PDIP8 – 8 pin Plastic DIP, 0.25mm lead frame, Package Outline	18
Table 16. PDIP8 – 8 pin Plastic DIP, 0.25mm lead frame, Package Mechanical Data	18
Figure 13.SO8W – 8 lead Plastic Small Outline, 208 mils body width, Package Outline	19
Table 17. SO8W – 8 lead Plastic Small Outline, 208 mils body width, Package Mechanical Data	19
Figure 14.SO8N – 8 lead Plastic Small Outline, 150 mils body width, Package Outline	20
Table 18. SO8N – 8 lead Plastic Small Outline, 150 mils body width, Package Mechanical Data	20
Figure 15.TSSOP8 – 8 lead Thin Shrink Small Outline, Package Outline	21
Table 19. TSSOP8 – 8 lead Thin Shrink Small Outline, Package Mechanical Data	21
PART NUMBERING	22
Table 20. Ordering Information Scheme	22
REVISION HISTORY	23
Table 21. Document Revision History	23

SUMMARY DESCRIPTION

These I²C-compatible electrically erasable programmable memory (EEPROM) devices are organized as 64K x 8 bits.

Figure 2. Logic Diagram

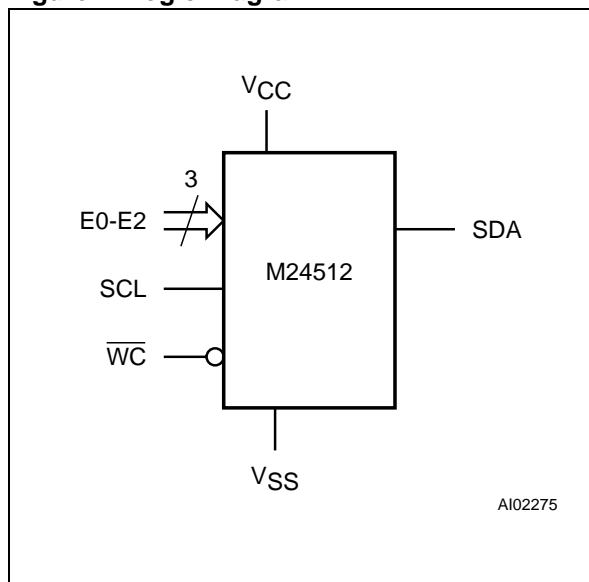

Table 2. Signal Names

E0, E1, E2	Chip Enable
SDA	Serial Data
SCL	Serial Clock
\overline{WC}	Write Control
VCC	Supply Voltage
VSS	Ground

I²C uses a two-wire serial interface, comprising a bi-directional data line and a clock line. The devices carry a built-in 4-bit Device Type Identifier code (1010) in accordance with the I²C bus definition.

The device behaves as a slave in the I²C protocol, with all memory operations synchronized by the serial clock. Read and Write operations are initiated by a Start condition, generated by the bus mas-

ter. The Start condition is followed by a Device Select Code and Read/Write bit (RW) (as described in Table 3.), terminated by an acknowledge bit.

When writing data to the memory, the device inserts an acknowledge bit during the 9th bit time, following the bus master's 8-bit transmission. When data is read by the bus master, the bus master acknowledges the receipt of the data byte in the same way. Data transfers are terminated by a Stop condition after an Ack for Write, and after a NoAck for Read.

Power On Reset

In order to prevent data corruption and inadvertent Write operations during Power-up, a Power On Reset (POR) circuit is included. At Power-up, the device will not respond to any command until VCC has reached the Power On Reset threshold voltage (this threshold is lower than the VCC min operating voltage defined in Tables 8 and 9). In the same way, as soon as VCC drops from the normal operating voltage, below the Power On Reset threshold voltage, the device stops to respond to any command.

Prior to selecting and issuing commands to the memory, a valid and stable VCC voltage must be applied. This voltage must remain stable and valid until the end of the transmission of the command and, for a Write instruction, until the completion of the internal write cycle (t_W).

Figure 3. DIP, SO and TSSOP Connections

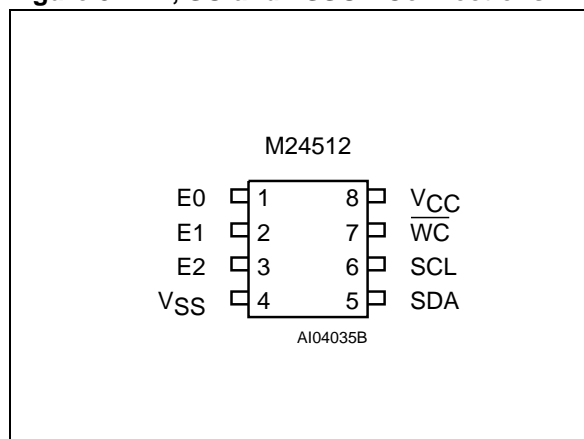

Note: See PACKAGE MECHANICAL section for package dimensions, and how to identify pin-1.

SIGNAL DESCRIPTION

Serial Clock (SCL). This input signal is used to strobe all data in and out of the device. In applications where this signal is used by slave devices to synchronize the bus to a slower clock, the bus master must have an open drain output, and a pull-up resistor must be connected from Serial Clock (SCL) to V_{CC} . (Figure 4. indicates how the value of the pull-up resistor can be calculated). In most applications, though, this method of synchronization is not employed, and so the pull-up resistor is not necessary, provided that the bus master has a push-pull (rather than open drain) output.

Serial Data (SDA). This bi-directional signal is used to transfer data in or out of the device. It is an open drain output that may be wire-OR'ed with other open drain or open collector signals on the bus. A pull up resistor must be connected from Serial Data (SDA) to V_{CC} . (Figure 4. indicates how the value of the pull-up resistor can be calculated).

Chip Enable (E0, E1, E2). These input signals are used to set the value that is to be looked for on the three least significant bits (b3, b2, b1) of the 7-bit Device Select Code. These inputs must be tied to V_{CC} or V_{SS} , to establish the Device Select Code. When not connected (left floating), these inputs are read as Low (0,0,0).

Write Control (WC). This input signal is useful for protecting the entire contents of the memory from inadvertent write operations. Write operations are disabled to the entire memory array when Write Control (WC) is driven High. When unconnected, the signal is internally read as V_{IL} , and Write operations are allowed.

When Write Control (WC) is driven High, Device Select and Address bytes are acknowledged, Data bytes are not acknowledged.

Figure 4. Maximum R_p Value versus Bus Parasitic Capacitance (C) for an I²C Bus

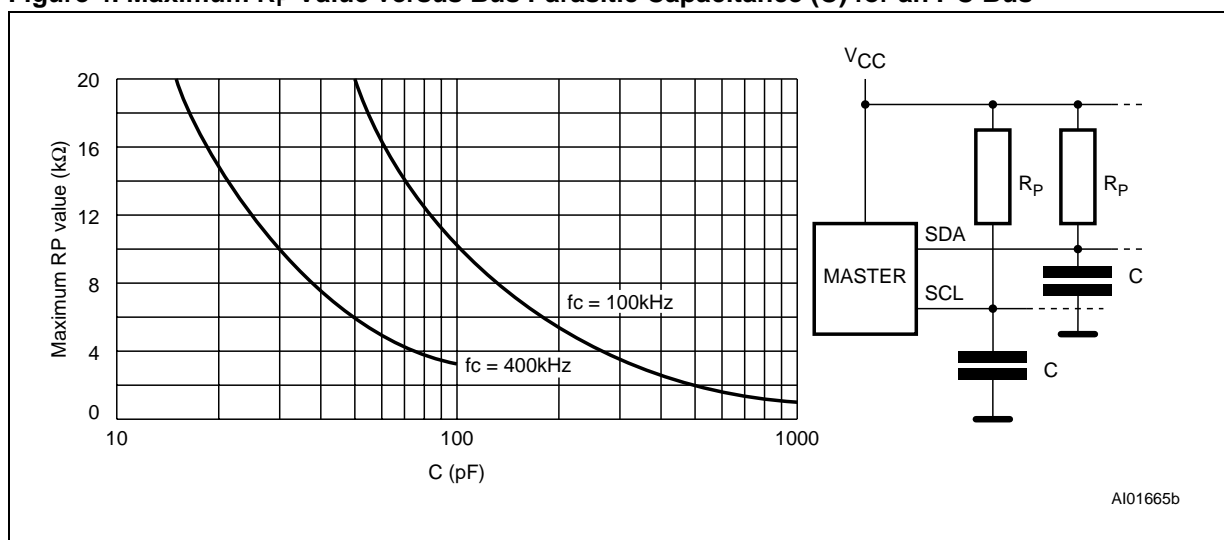

Figure 5. I²C Bus Protocol

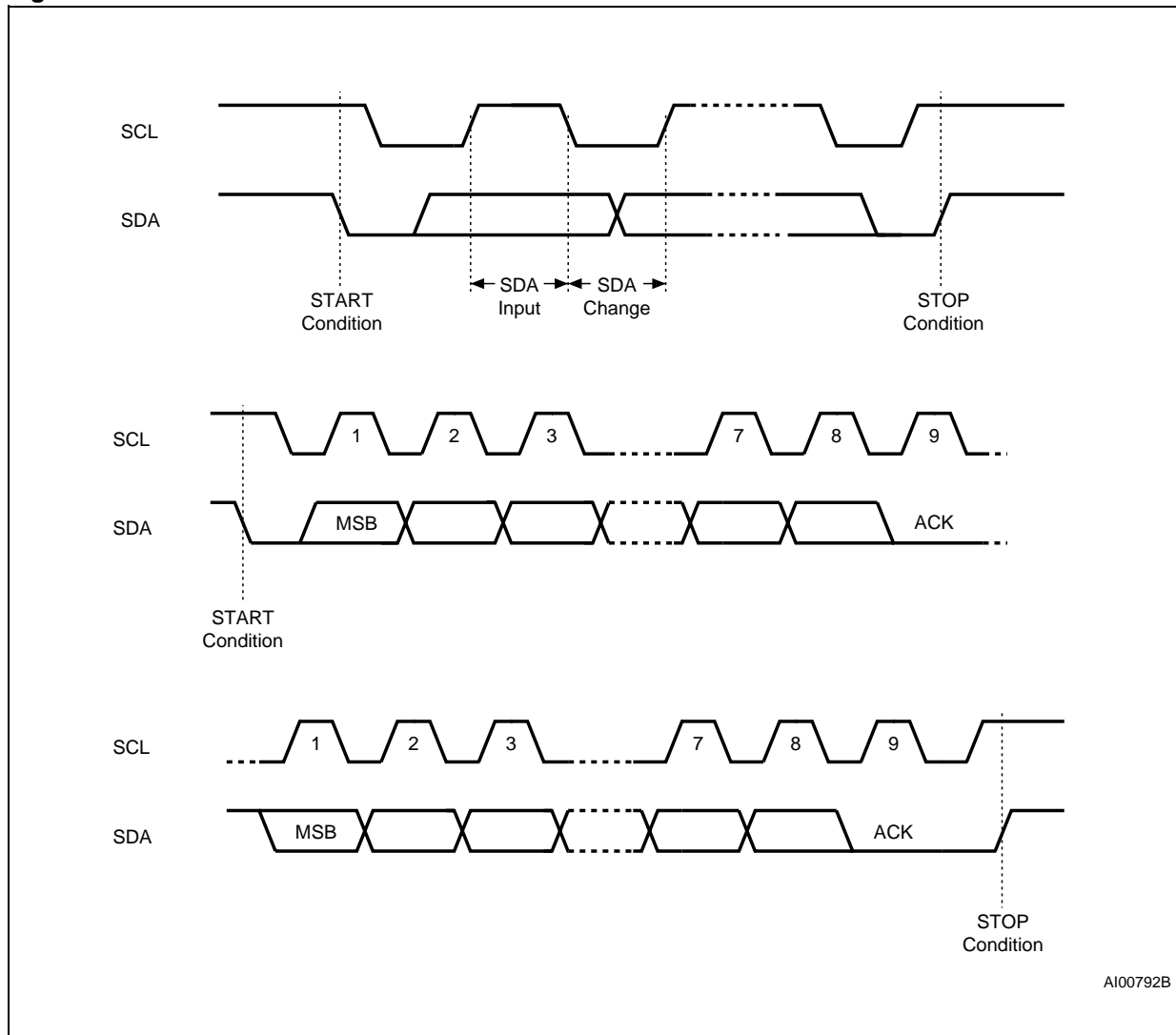

Table 3. Device Select Code

	Device Type Identifier ¹				Chip Enable Address ²			R \bar{W}
	b7	b6	b5	b4	b3	b2	b1	b0
Device Select Code	1	0	1	0	E2	E1	E0	R \bar{W}

Note: 1. The most significant bit, b7, is sent first.

2. E0, E1 and E2 are compared against the respective external pins on the memory device.

Table 4. Most Significant Byte

b15	b14	b13	b12	b11	b10	b9	b8
-----	-----	-----	-----	-----	-----	----	----

Table 5. Least Significant Byte

b7	b6	b5	b4	b3	b2	b1	b0
----	----	----	----	----	----	----	----

DEVICE OPERATION

The device supports the I²C protocol. This is summarized in [Figure 5](#). Any device that sends data on to the bus is defined to be a transmitter, and any device that reads the data to be a receiver. The device that controls the data transfer is known as the bus master, and the other as the slave device. A data transfer can only be initiated by the bus master, which will also provide the serial clock for synchronization. The M24512 device is always a slave in all communication.

Start Condition

Start is identified by a falling edge of Serial Data (SDA) while Serial Clock (SCL) is stable in the High state. A Start condition must precede any data transfer command. The device continuously monitors (except during a Write cycle) Serial Data (SDA) and Serial Clock (SCL) for a Start condition, and will not respond unless one is given.

Stop Condition

Stop is identified by a rising edge of Serial Data (SDA) while Serial Clock (SCL) is stable and driven High. A Stop condition terminates communication between the device and the bus master. A Read command that is followed by NoAck can be followed by a Stop condition to force the device into the Stand-by mode. A Stop condition at the end of a Write command triggers the internal Write cycle.

Acknowledge Bit (ACK)

The acknowledge bit is used to indicate a successful byte transfer. The bus transmitter, whether it be bus master or slave device, releases Serial Data (SDA) after sending eight bits of data. During the 9th clock pulse period, the receiver pulls Serial

Data (SDA) Low to acknowledge the receipt of the eight data bits.

Data Input

During data input, the device samples Serial Data (SDA) on the rising edge of Serial Clock (SCL). For correct device operation, Serial Data (SDA) must be stable during the rising edge of Serial Clock (SCL), and the Serial Data (SDA) signal must change *only* when Serial Clock (SCL) is driven Low.

Memory Addressing

To start communication between the bus master and the slave device, the bus master must initiate a Start condition. Following this, the bus master sends the Device Select Code, shown in [Table 3](#). (on Serial Data (SDA), most significant bit first).

The Device Select Code consists of a 4-bit Device Type Identifier, and a 3-bit Chip Enable "Address" (E2, E1, E0). To address the memory array, the 4-bit Device Type Identifier is 1010b.

Up to eight memory devices can be connected on a single I²C bus. Each one is given a unique 3-bit code on the Chip Enable (E0, E1, E2) inputs. When the Device Select Code is received, the device only responds if the Chip Enable Address is the same as the value on the Chip Enable (E0, E1, E2) inputs.

The 8th bit is the Read/Write bit (\overline{RW}). This bit is set to 1 for Read and 0 for Write operations.

If a match occurs on the Device Select code, the corresponding device gives an acknowledgment on Serial Data (SDA) during the 9th bit time. If the device does not match the Device Select code, it deselected itself from the bus, and goes into Stand-by mode.

Table 6. Operating Modes

Mode	\overline{RW} bit	\overline{WC} ¹	Bytes	Initial Sequence
Current Address Read	1	X	1	START, Device Select, $\overline{RW} = 1$
Random Address Read	0	X	1	START, Device Select, $\overline{RW} = 0$, Address
	1	X		reSTART, Device Select, $\overline{RW} = 1$
Sequential Read	1	X	≥ 1	Similar to Current or Random Address Read
Byte Write	0	V _{IL}	1	START, Device Select, $\overline{RW} = 0$
Page Write	0	V _{IL}	≤ 128	START, Device Select, $\overline{RW} = 0$

Note: 1. X = V_{IH} or V_{IL}.

Figure 6. Write Mode Sequences with $\overline{WC}=1$ (data write inhibited)

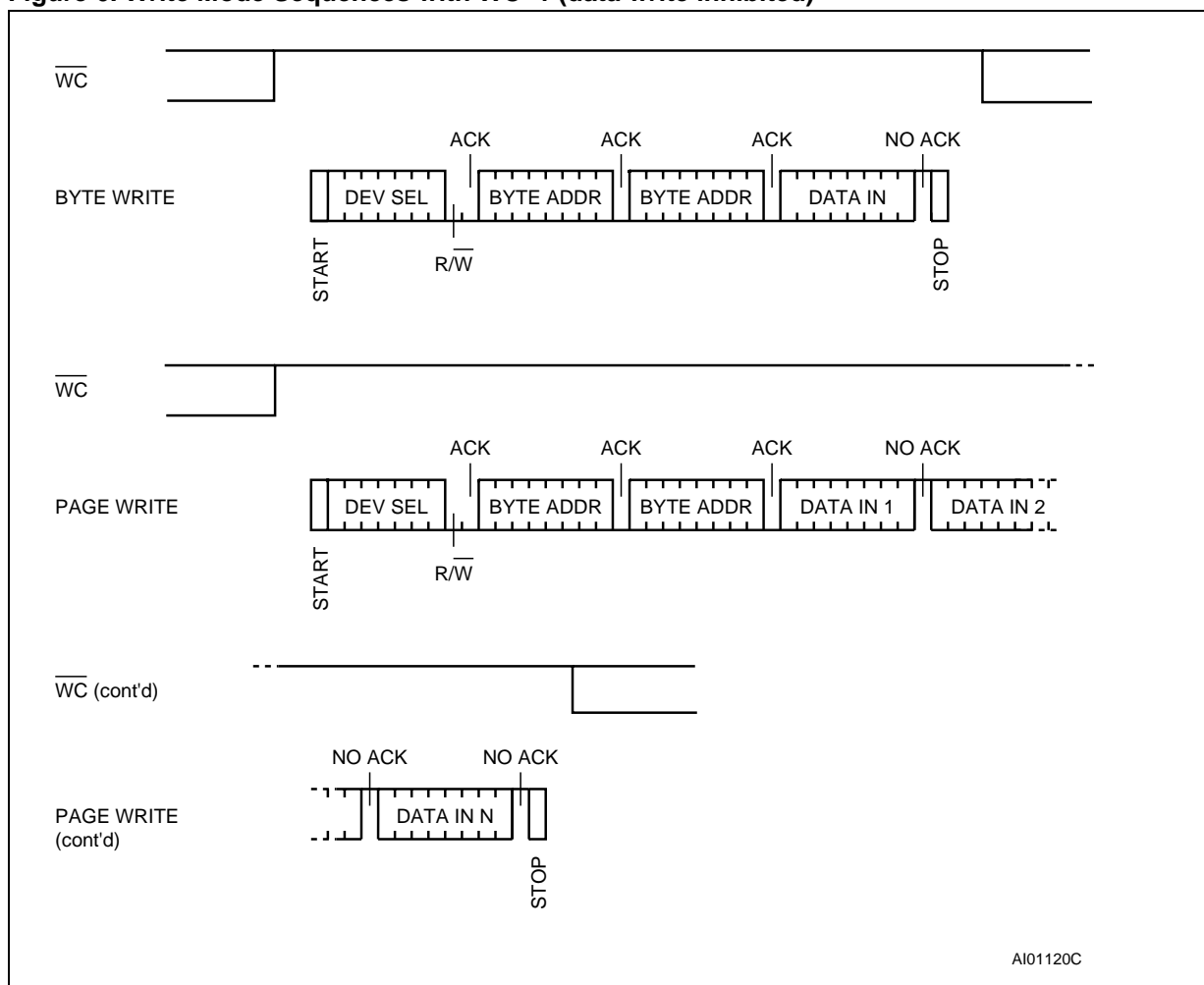

AI01120C

Write Operations

Following a Start condition the bus master sends a Device Select Code with the Read/Write bit (\overline{RW}) reset to 0. The device acknowledges this, as shown in Figure 7., and waits for two address bytes. The device responds to each address byte with an acknowledge bit, and then waits for the data byte.

Writing to the memory may be inhibited if Write Control (\overline{WC}) is driven High. Any Write instruction with Write Control (\overline{WC}) driven High (during a period of time from the Start condition until the end of the two address bytes) will not modify the memory contents, and the accompanying data bytes are not acknowledged, as shown in Figure 6..

Each data byte in the memory has a 16-bit (two byte wide) address. The Most Significant Byte (Table 4.) is sent first, followed by the Least Significant Byte (Table 5.). Bits b15 to b0 form the address of the byte in memory.

When the bus master generates a Stop condition immediately after the Ack bit (in the “10th bit” time slot), either at the end of a Byte Write or a Page Write, the internal Write cycle is triggered. A Stop condition at any other time slot does not trigger the internal Write cycle.

After the Stop condition, the delay t_{W} , and the successful completion of a Write operation, the device’s internal address counter is incremented automatically, to point to the next byte address after the last one that was modified.

During the internal Write cycle, Serial Data (SDA) is disabled internally, and the device does not respond to any requests.

Byte Write

After the Device Select code and the address bytes, the bus master sends one data byte. If the addressed location is Write-protected, by Write Control (\overline{WC}) being driven High, the device replies with NoAck, and the location is not modified. If, instead, the addressed location is not Write-protect-



ed, the device replies with Ack. The bus master terminates the transfer by generating a Stop condition, as shown in Figure 7.

Page Write

The Page Write mode allows up to 128 bytes to be written in a single Write cycle, provided that they are all located in the same 'row' in the memory: that is, the most significant memory address bits (b15-b7) are the same. If more bytes are sent than will fit up to the end of the row, a condition known as 'roll-over' occurs. This should be avoided, as

data starts to become overwritten in an implementation dependent way.

The bus master sends from 1 to 128 bytes of data, each of which is acknowledged by the device if Write Control (\overline{WC}) is Low. If Write Control (\overline{WC}) is High, the contents of the addressed memory location are not modified, and each data byte is followed by a NoAck. After each byte is transferred, the internal byte address counter (the 7 least significant address bits only) is incremented. The transfer is terminated by the bus master generating a Stop condition.

Figure 7. Write Mode Sequences with $\overline{WC}=0$ (data write enabled)

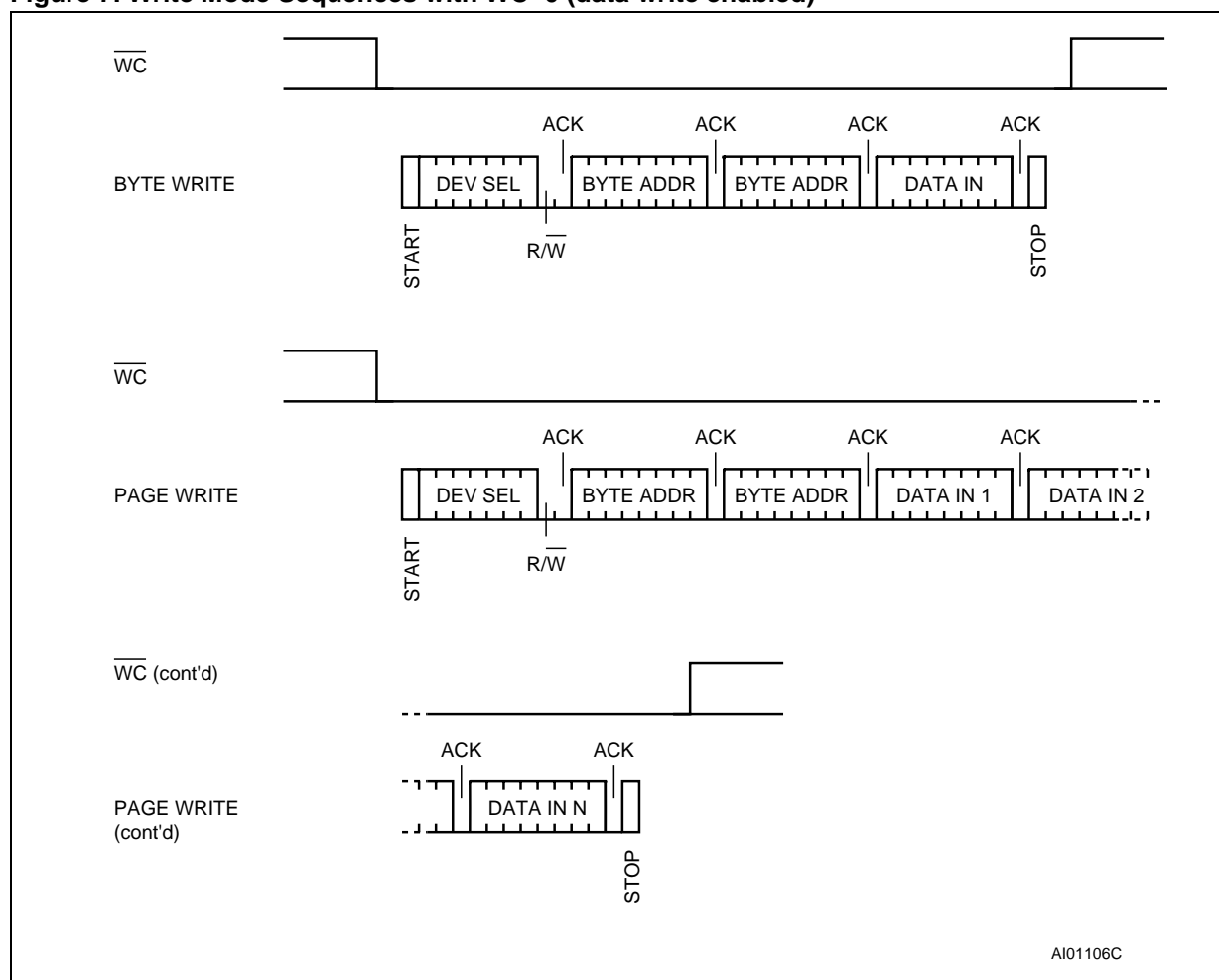
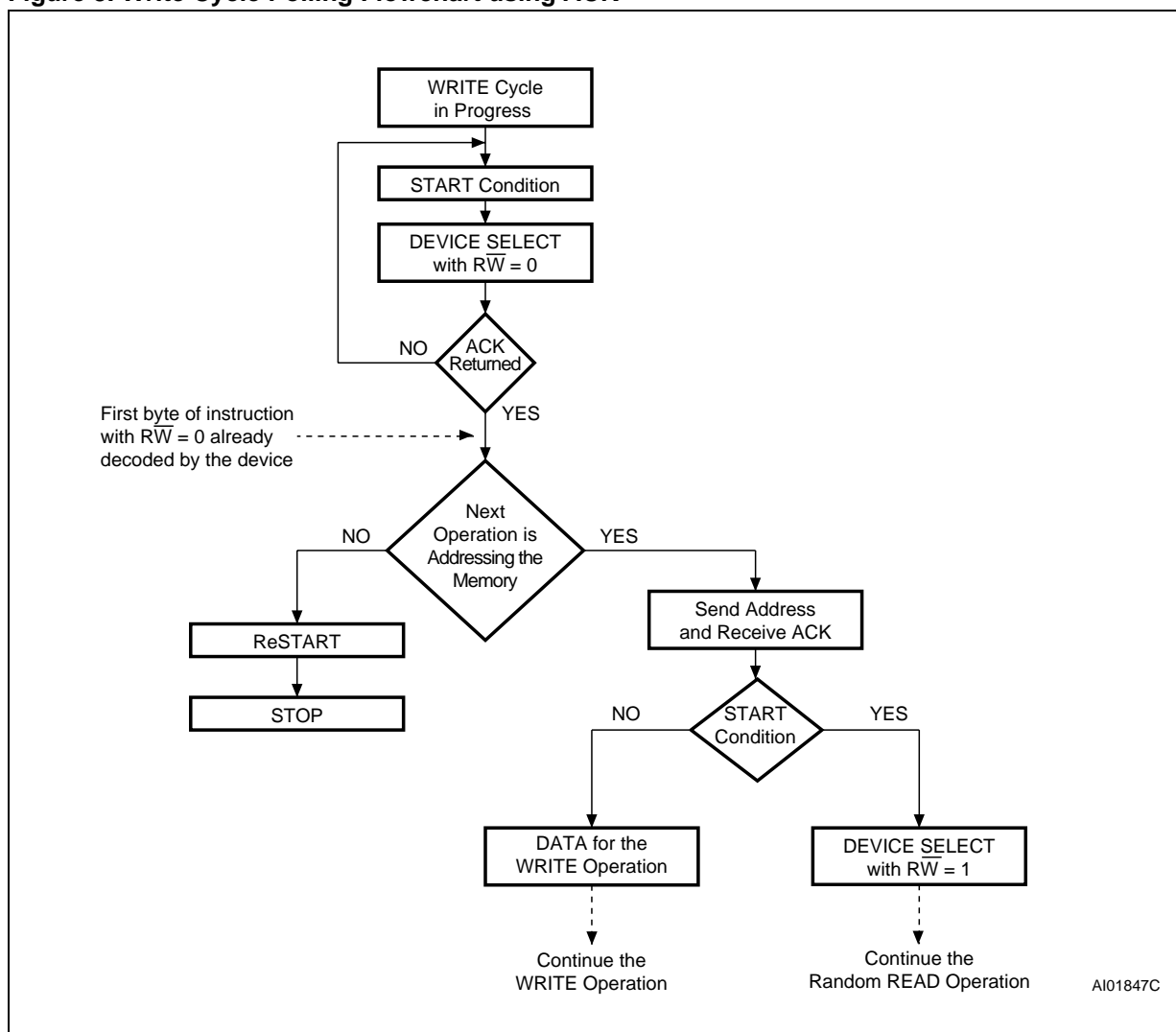

Figure 8. Write Cycle Polling Flowchart using ACK



Minimizing System Delays by Polling On ACK

During the internal Write cycle, the device disconnects itself from the bus, and writes a copy of the data from its internal latches to the memory cells. The maximum Write time (t_w) is shown in Table 14., but the typical time is shorter. To make use of this, a polling sequence can be used by the bus master.

The sequence, as shown in Figure 8., is:

- Initial condition: a Write cycle is in progress.
- Step 1: the bus master issues a Start condition followed by a Device Select Code (the first byte of the new instruction).
- Step 2: if the device is busy with the internal Write cycle, no Ack will be returned and the bus master goes back to Step 1. If the device has terminated the internal Write cycle, it responds with an Ack, indicating that the device is ready to receive the second part of the instruction (the first byte of this instruction having been sent during Step 1).

Figure 9. Read Mode Sequences

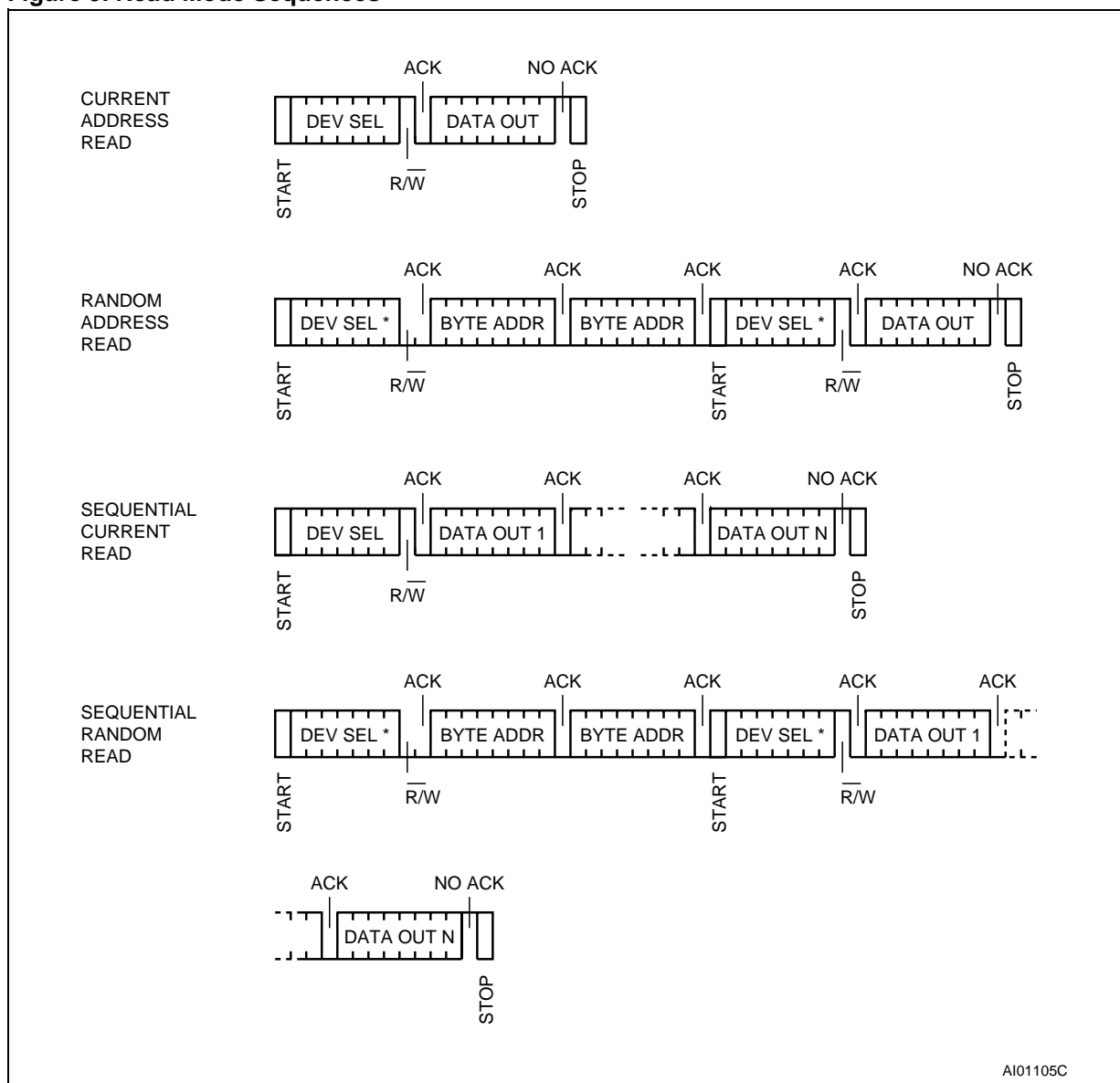

Note: 1. The seven most significant bits of the Device Select Code of a Random Read (in the 1st and 4th bytes) must be identical.

Read Operations

Read operations are performed independently of the state of the Write Control (WC) signal.

After the successful completion of a Read operation, the device's internal address counter is incremented by one, to point to the next byte address.

Random Address Read

A dummy Write is first performed to load the address into this address counter (as shown in Figure 9.) but *without* sending a Stop condition. Then, the bus master sends another Start condition, and repeats the Device Select Code, with the Read/Write bit (RW) set to 1. The device acknowledges

this, and outputs the contents of the addressed byte. The bus master must *not* acknowledge the byte, and terminates the transfer with a Stop condition.

Current Address Read

For the Current Address Read operation, following a Start condition, the bus master only sends a Device Select Code with the Read/Write bit (RW) set to 1. The device acknowledges this, and outputs the byte addressed by the internal address counter. The counter is then incremented. The bus master terminates the transfer with a Stop condition, as shown in Figure 9., *without* acknowledging the byte.

Sequential Read

This operation can be used after a Current Address Read or a Random Address Read. The bus master *does* acknowledge the data byte output, and sends additional clock pulses so that the device continues to output the next byte in sequence. To terminate the stream of bytes, the bus master must *not* acknowledge the last byte, and *must* generate a Stop condition, as shown in [Figure 9](#).

The output data comes from consecutive addresses, with the internal address counter automatically incremented after each byte output. After the last memory address, the address counter 'rolls-over', and the device continues to output data from memory address 00h.

Acknowledge in Read Mode

For all Read commands, the device waits, after each byte read, for an acknowledgment during the 9th bit time. If the bus master does not drive Serial Data (SDA) Low during this time, the device terminates the data transfer and switches to its Standby mode.

INITIAL DELIVERY STATE

The device is delivered with all bits in the memory array set to 1 (each byte contains FFh).

MAXIMUM RATING

Stressing the device outside the ratings listed in [Table 7](#), may cause permanent damage to the device. These are stress ratings only, and operation of the device at these, or any other conditions outside those indicated in the Operating sections of

this specification, is not implied. Exposure to Absolute Maximum Rating conditions for extended periods may affect device reliability. Refer also to the STMicroelectronics SURE Program and other relevant quality documents.

Table 7. Absolute Maximum Ratings

Symbol	Parameter	Min.	Max.	Unit
T _A	Ambient Operating Temperature	-40	125	°C
T _{STG}	Storage Temperature	-65	150	°C
T _{LEAD}	Lead Temperature during Soldering	See note ⁽¹⁾		°C
V _{IO}	Input or Output range	-0.50	6.5	V
V _{CC}	Supply Voltage	-0.50	6.5	V
V _{ESD}	Electrostatic Discharge Voltage (Human Body model) ²	-4000	4000	V

Note: 1. Compliant with JEDEC Std J-STD-020C (for small body, Sn-Pb or Pb assembly), the ST ECOPACK[®] 7191395 specification, and the European directive on Restrictions on Hazardous Substances (RoHS) 2002/95/EU

2. AEC-Q100-002 (compliant with JEDEC Std JESD22-A114A, C1=100pF, R1=1500Ω, R2=500Ω)

DC AND AC PARAMETERS

This section summarizes the operating and measurement conditions, and the DC and AC characteristics of the device. The parameters in the DC and AC Characteristic tables that follow are derived from tests performed under the Measure-

ment Conditions summarized in the relevant tables. Designers should check that the operating conditions in their circuit match the measurement conditions when relying on the quoted parameters.

Table 8. Operating Conditions (M24512 – W)

Symbol	Parameter	Min.	Max.	Unit
V_{CC}	Supply Voltage	2.5	5.5	V
T_A	Ambient Operating Temperature	-40	85	°C

Table 9. Operating Conditions (M24512 – R)

Symbol	Parameter	Min.	Max.	Unit
V_{CC}	Supply Voltage	1.8	5.5	V
T_A	Ambient Operating Temperature	-40	85	°C

Table 10. AC Measurement Conditions

Symbol	Parameter	Min.	Max.	Unit
C_L	Load Capacitance	100		pF
	Input Rise and Fall Times		50	ns
	Input Levels	0.2V _{CC} to 0.8V _{CC}		V
	Input and Output Timing Reference Levels	0.3V _{CC} to 0.7V _{CC}		V

Figure 10. AC Measurement I/O Waveform

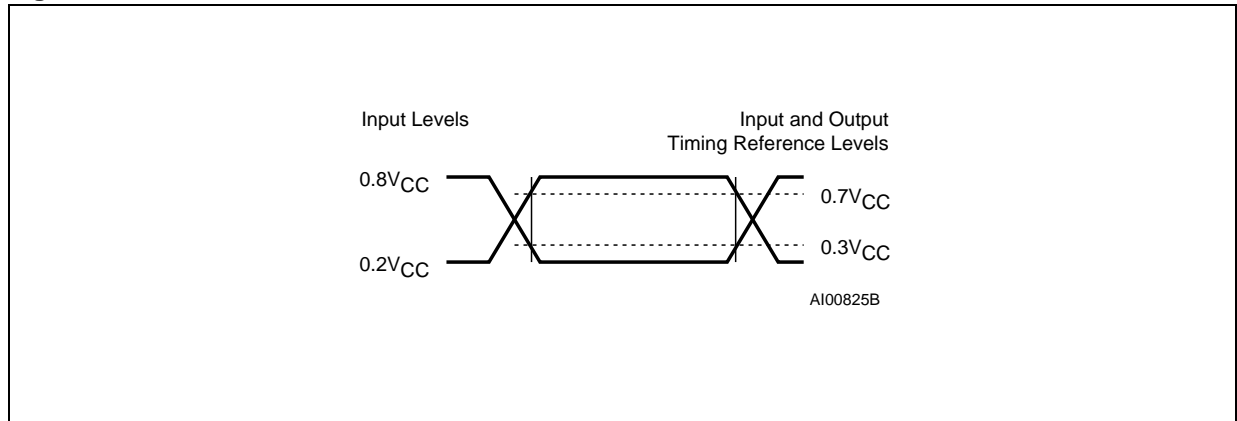

Table 11. Input Parameters

Symbol	Parameter ^(1,2)	Test Condition	Min.	Max.	Unit
C _{IN}	Input Capacitance (SDA)			8	pF
C _{IN}	Input Capacitance (other pins)			6	pF
Z _L ⁽³⁾	Input Impedance (E2, E1, E0, WC)	V _{IN} < 0.3V _{CC}	30		kΩ
Z _H ⁽³⁾	Input Impedance (E2, E1, E0, WC)	V _{IN} > 0.7V _{CC}	500		kΩ
t _{NS}	Pulse width ignored (Input Filter on SCL and SDA)	Single glitch		100	ns

Note: 1. T_A = 25 °C, f = 400 kHz
 2. Sampled only, not 100% tested.
 3. E2,E1,E0: Input impedance when the memory is selected (after a Start condition).

Table 12. DC Characteristics (M24512 – W)

Symbol	Parameter	Test Condition	Min.	Max.	Unit
I _{LI}	Input Leakage Current (SCL, SDA, E0, E1, E2)	V _{IN} = V _{SS} or V _{CC} device in Standby mode ⁽¹⁾		± 2	μA
I _{LO}	Output Leakage Current	V _{OUT} = V _{SS} or V _{CC} , SDA in Hi-Z		± 2	μA
I _{CC}	Supply Current	V _{CC} = 2.5V, f _c =400kHz (rise/fall time < 30ns)		1	mA
		V _{CC} = 5.5V, f _c =400kHz (rise/fall time < 30ns)		2	mA
I _{CC1}	Stand-by Supply Current	V _{IN} = V _{SS} or V _{CC} , V _{CC} = 2.5 V		2	μA
		V _{IN} = V _{SS} or V _{CC} , V _{CC} = 5.5 V		5	μA
V _{IL}	Input Low Voltage (SCL, SDA, WC)		-0.45	0.3V _{CC}	V
V _{IH}	Input High Voltage (SCL, SDA, WC)		0.7V _{CC}	V _{CC} +1	V
V _{OL}	Output Low Voltage	I _{OL} = 2.1 mA, V _{CC} = 2.5 V		0.4	V

Note: 1. When the device is selected (after a START condition), the Ei inputs have a different input impedance, as defined in Table 11.

Table 13. DC Characteristics⁽¹⁾ (M24512 – R)

Symbol	Parameter	Test Condition	Min.	Max.	Unit
I _{LI}	Input Leakage Current (SCL, SDA, E2, E1, E0)	V _{IN} = V _{SS} or V _{CC} device in Stand-by mode		± 2	μA
I _{LO}	Output Leakage Current	V _{OUT} = V _{SS} or V _{CC} , SDA in Hi-Z		± 2	μA
I _{CC}	Supply Current	V _{CC} =1.8V, f _c = 400kHz (rise/fall time < 30ns)		1	mA
I _{CC1}	Standby Supply Current	V _{IN} = V _{SS} or V _{CC} , V _{CC} = 1.8 V		2	μA
V _{IL}	Input Low Voltage		-0.45	0.3 V _{CC}	V
V _{IH}	Input High Voltage		0.7V _{CC}	V _{CC} +1	V
V _{OL}	Output Low Voltage	I _{OL} = 0.7 mA, V _{CC} = 1.8 V		0.2	V

Note: 1. The information contained in Table 13. is related to the new M24512 (process letter "A") and is subject to change without previous notice.

Table 14. AC Characteristics (M24512 – W)

Symbol	Alt.	Parameter	Min.	Max.	Unit
f_c	f_{SCL}	Clock Frequency		400	kHz
t_{CHCL}	t_{HIGH}	Clock Pulse Width High	600		ns
t_{CLCH}	t_{LOW}	Clock Pulse Width Low	1300		ns
t_{CH1CH2}	t_R	Clock Rise Time		300	ns
t_{CL1CL2}	t_F	Clock Fall Time		300	ns
$t_{DH1DH2}^{(2)}$	t_R	SDA Rise Time	20	300	ns
$t_{DL1DL2}^{(2)}$	t_F	SDA Fall Time	20	300	ns
t_{DXCX}	$t_{SU:DAT}$	Data In Set Up Time	100		ns
t_{CLDX}	$t_{HD:DAT}$	Data In Hold Time	0		ns
t_{CLQX}	t_{DH}	Data Out Hold Time	200		ns
$t_{CLQV}^{(3)}$	t_{AA}	Clock Low to Next Data Valid (Access Time)	200	900	ns
$t_{CHDX}^{(1)}$	$t_{SU:STA}$	Start Condition Set Up Time	600		ns
t_{DLCL}	$t_{HD:STA}$	Start Condition Hold Time	600		ns
t_{CHDH}	$t_{SU:STO}$	Stop Condition Set Up Time	600		ns
t_{DHDL}	t_{BUF}	Time between Stop Condition and Next Start Condition	1300		ns
t_W	t_{WR}	Write Time		5 or 10 ⁽⁴⁾	ms

Note: 1. For a reSTART condition, or following a Write cycle.

2. Sampled only, not 100% tested.

3. To avoid spurious START and STOP conditions, a minimum delay is placed between SCL=1 and the falling or rising edge of SDA.

4. For M24512 devices whose package marking shows the process letter "A" $t_W(\max) = 5\text{ms}$ whereas for M24512 devices whose package marking shows the process letter "V" $t_W(\max) = 10\text{ms}$

Table 15. AC Characteristics⁽¹⁾ (M24512 – R)

Symbol	Alt.	Parameter	Min.	Max.	Unit
f_c	f_{SCL}	Clock Frequency		400	kHz
t_{CHCL}	t_{HIGH}	Clock Pulse Width High	600		ns
t_{CLCH}	t_{LOW}	Clock Pulse Width Low	1300		ns
$t_{DL1DL2}^{(3)}$	t_F	SDA Fall Time	20	300	ns
t_{DXCX}	$t_{SU:DAT}$	Data In Set Up Time	100		ns
t_{CLDX}	$t_{HD:DAT}$	Data In Hold Time	0		ns
t_{CLQX}	t_{DH}	Data Out Hold Time	200		ns
$t_{CLQV}^{(4)}$	t_{AA}	Clock Low to Next Data Valid (Access Time)	200	900	ns
$t_{CHDX}^{(2)}$	$t_{SU:STA}$	Start Condition Set Up Time	600		ns
t_{DLCL}	$t_{HD:STA}$	Start Condition Hold Time	600		ns
t_{CHDH}	$t_{SU:STO}$	Stop Condition Set Up Time	600		ns
t_{DHDL}	t_{BUF}	Time between Stop Condition and Next Start Condition	1300		ns
t_W	t_{WR}	Write Time		10	ms

Note: 1. The information contained in Table 15. is related to the new M24512 (process letter "A") and is subject to change without previous notice.

2. For a reSTART condition, or following a Write cycle.

3. Sampled only, not 100% tested.

4. To avoid spurious START and STOP conditions, a minimum delay is placed between SCL=1 and the falling or rising edge of SDA.

Figure 11. AC Waveforms

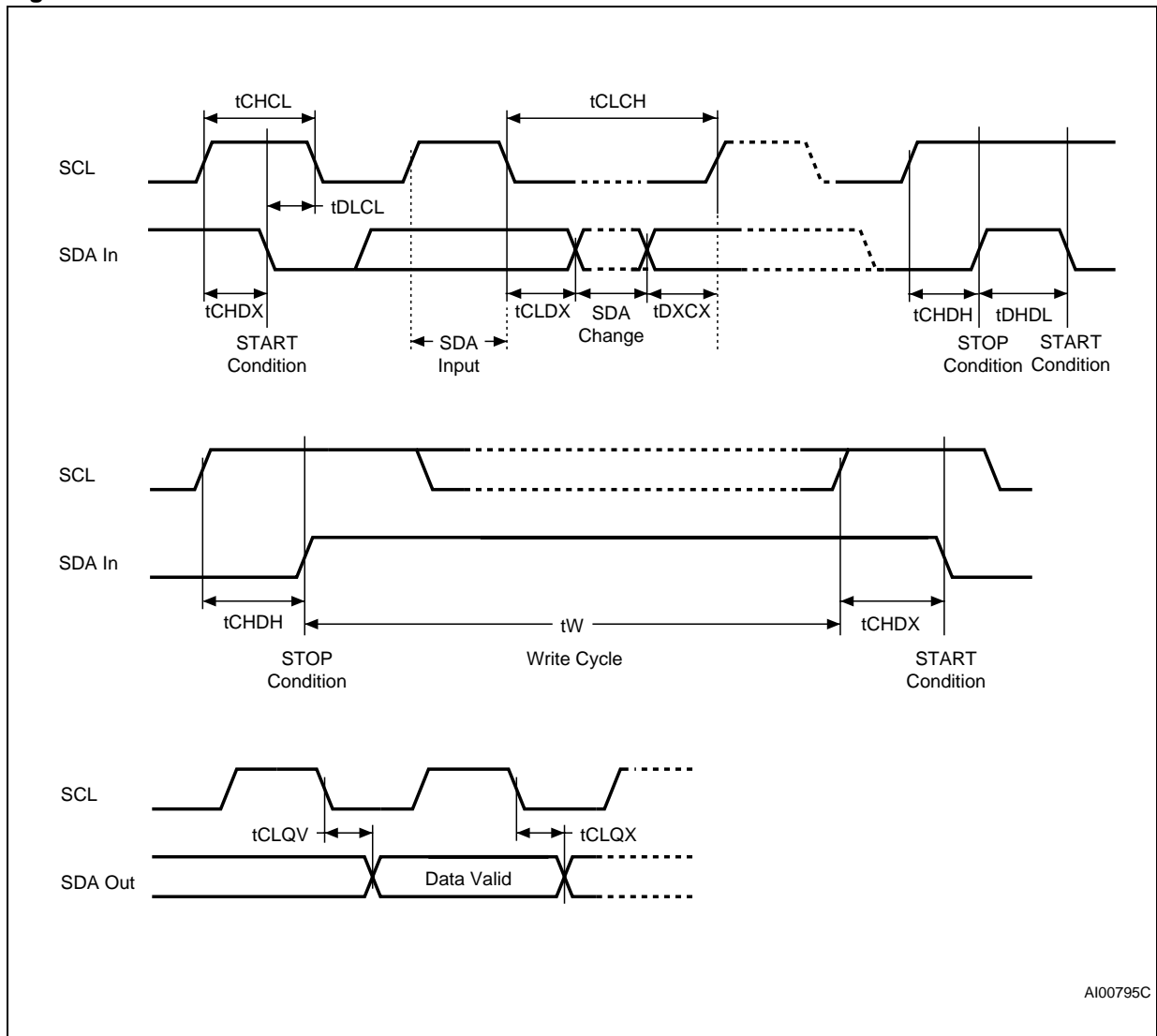

AI00795C

PACKAGE MECHANICAL

Figure 12. PDIP8 – 8 pin Plastic DIP, 0.25mm lead frame, Package Outline

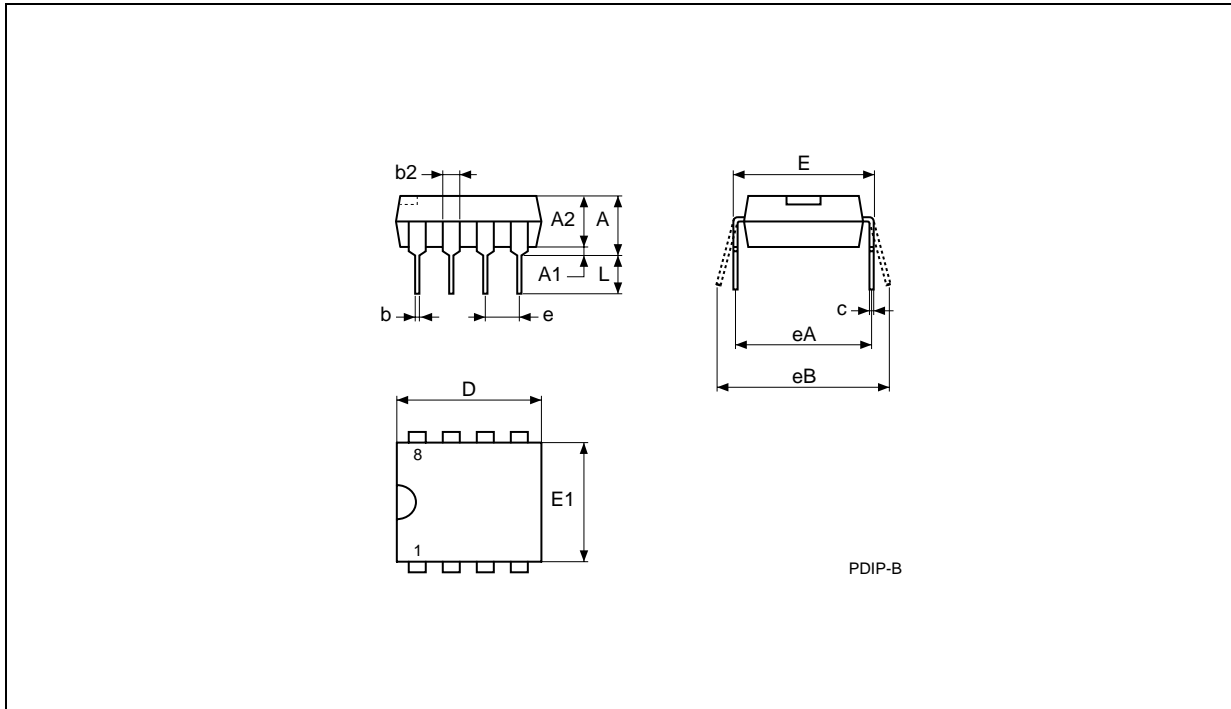

Note: Drawing is not to scale.

Table 16. PDIP8 – 8 pin Plastic DIP, 0.25mm lead frame, Package Mechanical Data

Symbol	millimeters			inches		
	Typ	Min	Max	Typ	Min	Max
A			5.33			0.210
A1		0.38			0.015	
A2	3.30	2.92	4.95	0.130	0.115	0.195
b	0.46	0.36	0.56	0.018	0.014	0.022
b2	1.52	1.14	1.78	0.060	0.045	0.070
c	0.25	0.20	0.36	0.010	0.008	0.014
D	9.27	9.02	10.16	0.365	0.355	0.400
E	7.87	7.62	8.26	0.310	0.300	0.325
E1	6.35	6.10	7.11	0.250	0.240	0.280
e	2.54	–	–	0.100	–	–
eA	7.62	–	–	0.300	–	–
eB			10.92			0.430
L	3.30	2.92	3.81	0.130	0.115	0.150

Figure 13. SO8W – 8 lead Plastic Small Outline, 208 mils body width, Package Outline

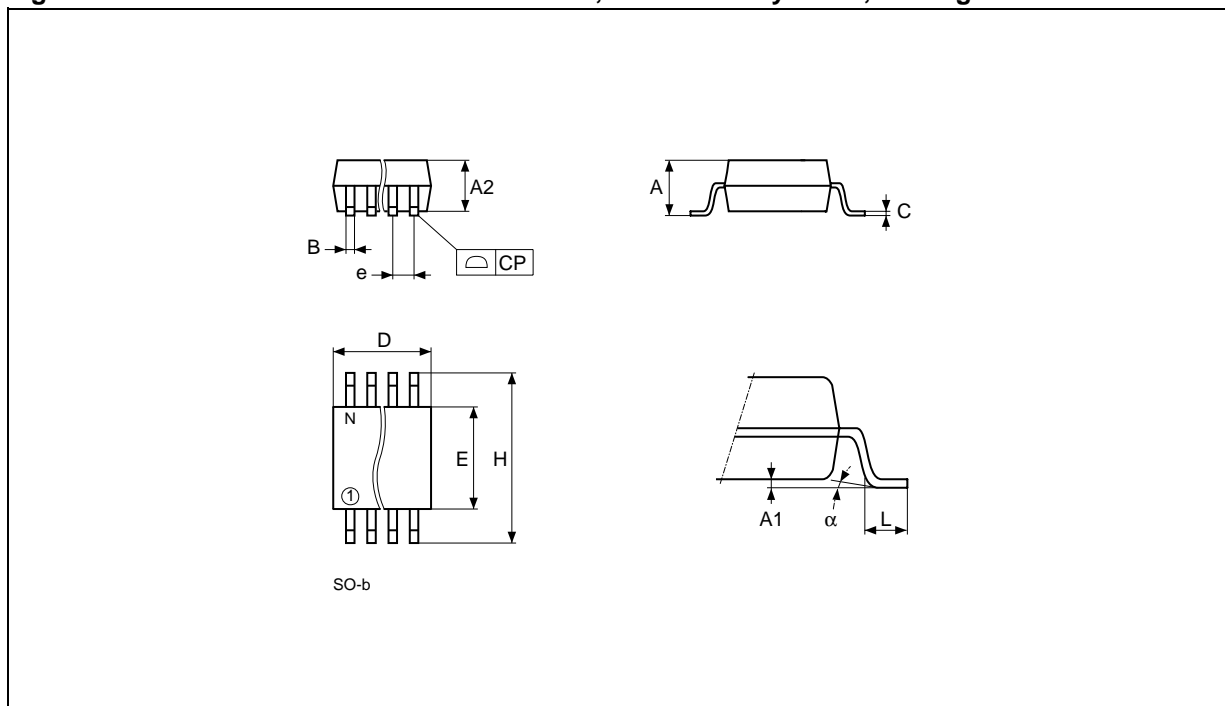

Note: Drawing is not to scale.

Table 17. SO8W – 8 lead Plastic Small Outline, 208 mils body width, Package Mechanical Data

Symbol	millimeters			inches		
	Typ	Min	Max	Typ	Min	Max
A			2.03			0.080
A1		0.10	0.25		0.004	0.010
A2			1.78			0.070
B		0.35	0.45		0.014	0.018
C	0.20	–	–	0.008	–	–
D		5.15	5.35		0.203	0.211
E		5.20	5.40		0.205	0.213
e	1.27	–	–	0.050	–	–
H		7.70	8.10		0.303	0.319
L		0.50	0.80		0.020	0.031
α		0°	10°		0°	10°
N	8			8		
CP			0.10			0.004

Figure 14. SO8N – 8 lead Plastic Small Outline, 150 mils body width, Package Outline

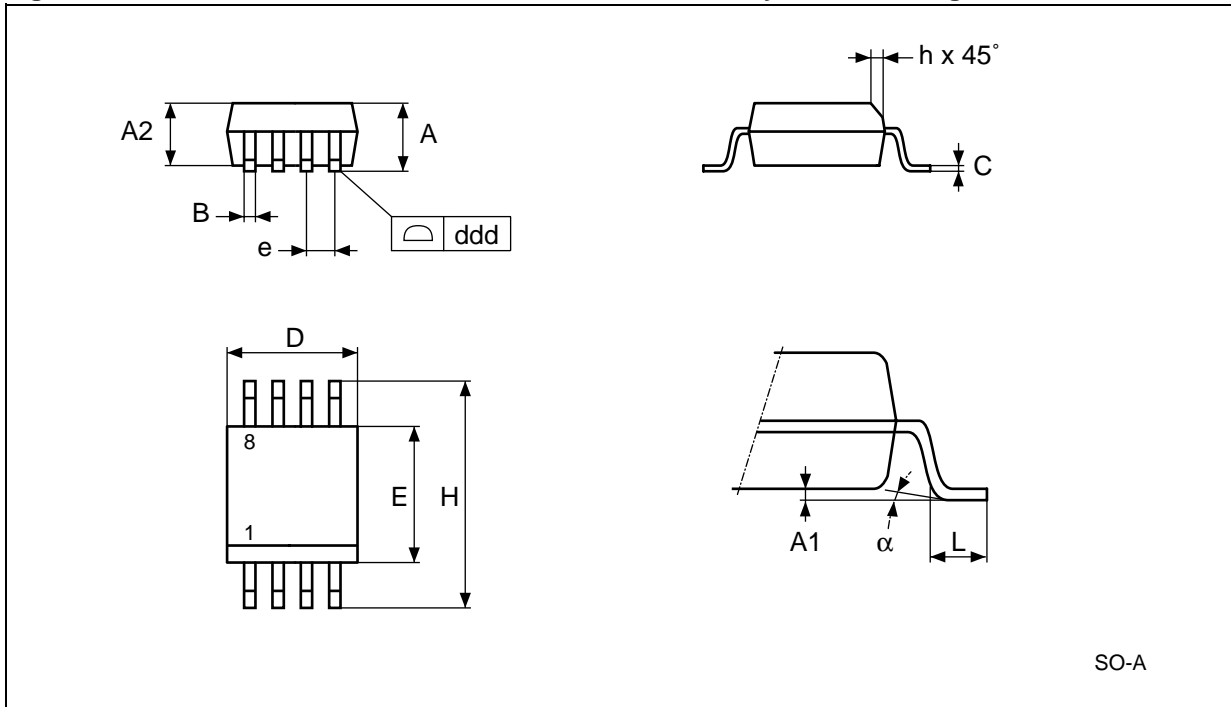

Note: Drawing is not to scale.

Table 18. SO8N – 8 lead Plastic Small Outline, 150 mils body width, Package Mechanical Data

Symbol	millimeters			inches		
	Typ	Min	Max	Typ	Min	Max
A		1.35	1.75		0.053	0.069
A1		0.10	0.25		0.004	0.010
A2		1.10	1.65		0.043	0.065
B		0.33	0.51		0.013	0.020
C		0.19	0.25		0.007	0.010
D		4.80	5.00		0.189	0.197
ddd			0.10			0.004
E		3.80	4.00		0.150	0.157
e	1.27	–	–	0.050	–	–
H		5.80	6.20		0.228	0.244
h		0.25	0.50		0.010	0.020
L		0.40	0.90		0.016	0.035
α		0°	8°		0°	8°
N		8			8	

Figure 15. TSSOP8 – 8 lead Thin Shrink Small Outline, Package Outline

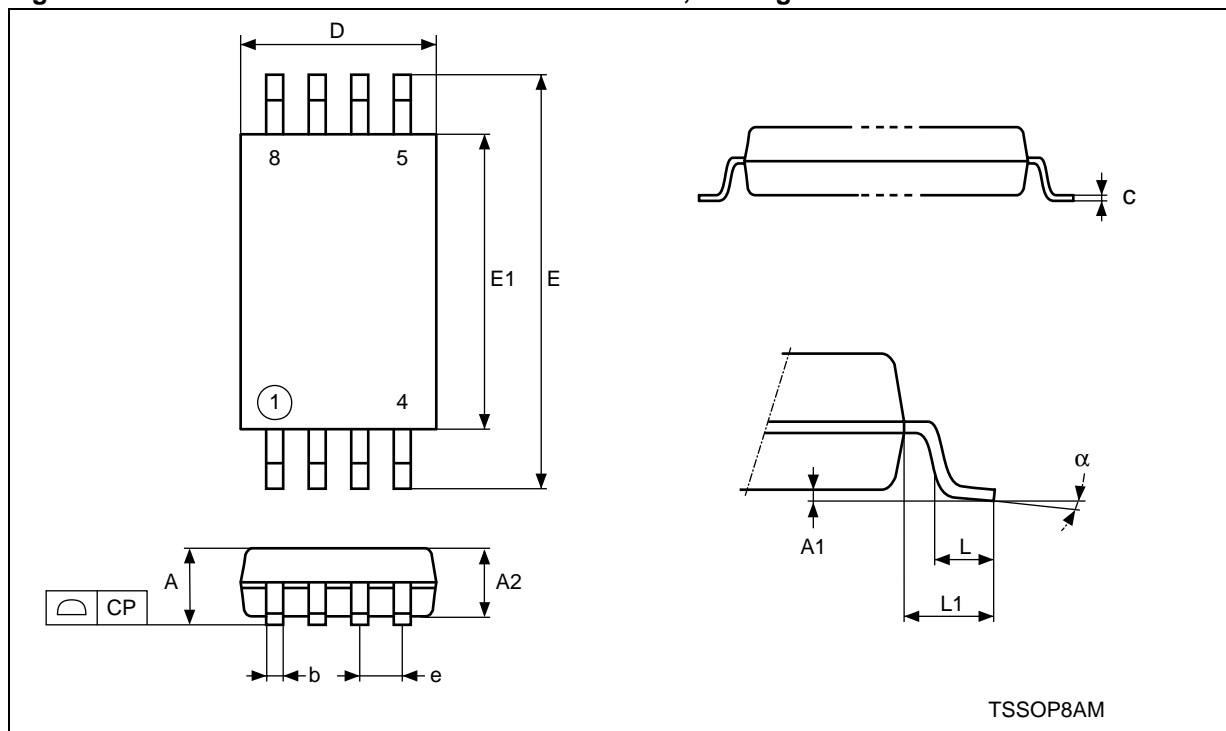

Note: Drawing is not to scale.

Table 19. TSSOP8 – 8 lead Thin Shrink Small Outline, Package Mechanical Data

Symbol	millimeters			inches		
	Typ	Min	Max	Typ	Min	Max
A			1.200			0.0472
A1		0.050	0.150		0.0020	0.0059
A2	1.000	0.800	1.050	0.0394	0.0315	0.0413
b		0.190	0.300		0.0075	0.0118
c		0.090	0.200		0.0035	0.0079
CP			0.100			0.0039
D	3.000	2.900	3.100	0.1181	0.1142	0.1220
e	0.650	–	–	0.0256	–	–
E	6.400	6.200	6.600	0.2520	0.2441	0.2598
E1	4.400	4.300	4.500	0.1732	0.1693	0.1772
L	0.600	0.450	0.750	0.0236	0.0177	0.0295
L1	1.000			0.0394		
α		0°	8°		0°	8°
N		8			8	

PART NUMBERING

Table 20. Ordering Information Scheme

Example:	M24512	-	W	MW	6	T	P
Device Type							
M24 = I ² C serial access EEPROM							
Device Function							
512 = 512 Kbit (64K x 8)							
Operating Voltage							
W = V _{CC} = 2.5 to 5.5V R = V _{CC} = 1.8 to 5.5V							
Package							
BN = PDIP8 MW = SO8 (208 mil width) MN = SO8 (150 mil body width) DW = TSSOP8							
Device Grade							
6 = Industrial temperature range, -40 to 85 °C. Device tested with standard test flow							
Option							
blank = Standard Packing T = Tape and Reel Packing							
Plating Technology							
blank = Standard SnPb plating P or G = Lead-Free and RoHS compliant							

For a list of available options (speed, package, etc.) or for further information on any aspect of this

device, please contact your nearest ST Sales Office.

REVISION HISTORY

Table 21. Document Revision History

Date	Revision	Description of Revision
29-Jan-2001	1.1	Lead Soldering Temperature in the Absolute Maximum Ratings table amended Write Cycle Polling Flow Chart using ACK illustration updated LGA8 and SO8(wide) packages added References to PSDIP8 changed to PDIP8, and Package Mechanical data updated
10-Apr-2001	1.2	LGA8 Package Mechanical data and illustration updated SO16 package removed
16-Jul-2001	1.3	LGA8 Package given the designator "LA"
02-Oct-2001	1.4	LGA8 Package mechanical data updated
13-Dec-2001	1.5	Document becomes Preliminary Data Test conditions for ILI, ILO, ZL and ZH made more precise VIL and VIH values unified. tNS value changed
12-Jun-2001	1.6	Document promoted to Full Datasheet
22-Oct-2003	2.0	Table of contents, and Pb-free options added. Minor wording changes in Summary Description, Power-On Reset, Memory Addressing, Write Operations, Read Operations. V _{IL} (min) improved to -0.45V.
02-Sep-2004	3.0	LGA8 package is Not for New Design. 5V and -S supply ranges, and Device Grade 5 removed. Absolute Maximum Ratings for V _{IO} (min) and V _{CC} (min) changed. Soldering temperature information clarified for RoHS compliant devices. Device grade information clarified. AEC-Q100-002 compliance. V _{IL} specification unified for SDA, SCL and WC
22-Feb-2005	4.0	INITIAL DELIVERY STATE is FFh (not necessarily the same as Erased). LGA package removed, TSSOP8 and SO8N packages added (see PACKAGE MECHANICAL section and Table 20., Ordering Information Scheme). Voltage range R (1.8V to 5.5V) also offered. Minor wording changes. Z _L Test Conditions modified in Table 11., Input Parameters and Note 3. added. I _{CC} and I _{CC1} values for V _{CC} = 5.5V added to Table 12., DC Characteristics (M24512 – W) . Power On Reset paragraph specified. t _W max value modified in Table 14., AC Characteristics (M24512 – W) and note 4 added. Plating technology changed in Table 20., Ordering Information Scheme . Resistance and capacitance renamed in Figure 4., Maximum R_p Value versus Bus Parasitic Capacitance (C) for an I²C Bus .

Information furnished is believed to be accurate and reliable. However, STMicroelectronics assumes no responsibility for the consequences of use of such information nor for any infringement of patents or other rights of third parties which may result from its use. No license is granted by implication or otherwise under any patent or patent rights of STMicroelectronics. Specifications mentioned in this publication are subject to change without notice. This publication supersedes and replaces all information previously supplied. STMicroelectronics products are not authorized for use as critical components in life support devices or systems without express written approval of STMicroelectronics.

The ST logo is a registered trademark of STMicroelectronics.
ECOPACK is a registered trademark of STMicroelectronics.
All other names are the property of their respective owners

© 2005 STMicroelectronics - All rights reserved

STMicroelectronics group of companies
Australia - Belgium - Brazil - Canada - China - Czech Republic - Finland - France - Germany - Hong Kong - India - Israel - Italy - Japan -
Malaysia - Malta - Morocco - Singapore - Spain - Sweden - Switzerland - United Kingdom - United States of America
www.st.com