



ICS300/ICS301/ICS302 QTClock™ Quick Turn Clock Synthesizer

Description

The ICS300 and ICS301 QTClocks™ generate a high quality, high frequency clock output and a reference from a low frequency crystal or clock input. They are designed to replace crystals and crystal oscillators in most electronic systems. The ICS302 can accept a higher frequency clock input to generate up to 200 MHz. The devices contain a One Time Programmable (OTP) ROM which is factory programmed with the PLL divider values to output a broad range of frequencies, from 6 to 200 MHz, allowing customer requests for different frequencies to be shipped in 1-3 days. Using Phase-Locked-Loop (PLL) techniques, the devices run from a standard fundamental mode, inexpensive crystal, or clock. They are smaller and less expensive than one oscillator.

Features

- Packaged as 8 pin SOIC 
- Quick turn frequency programming allows samples in one to three days
- Replaces nearly any crystal or oscillator
- ICS300 produces up to 100 MHz at 3.3V, ICS301 produces up to 200 MHz at 3.3V, ICS302 accepts up to 125 MHz clock input
- Easy to cascade with ICS5xx series
- Input crystal frequency of 5 - 27 MHz
- Input clock frequency of 2 - 125 MHz
- Low jitter - 50 ps one sigma
- Compatible with all popular CPUs
- Duty cycle of 45/55
- Operating voltages of 3.0 to 5.5V
- Full CMOS level outputs with 25mA drive capability at TTL levels
- Tri-state output + PLL power down pin
- Advanced, low power CMOS process

Block Diagram

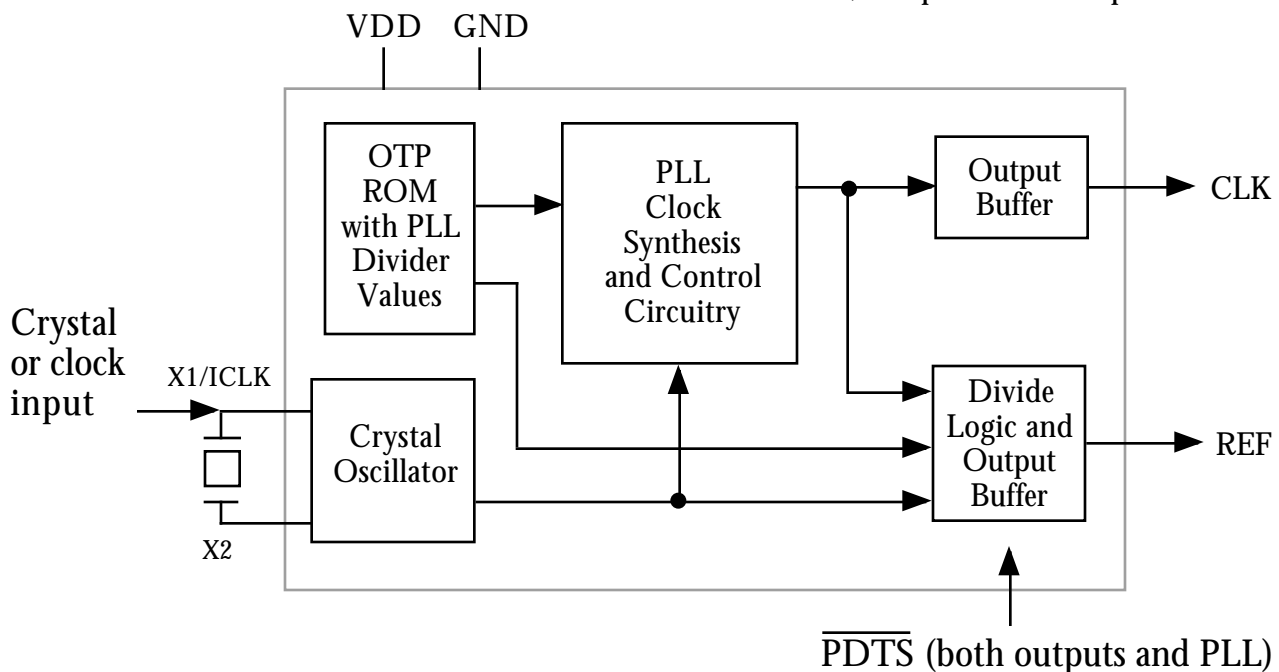



ICS300/ICS301/ICS302 QTClock™ Quick Turn Clock Synthesizer

Pin Assignments

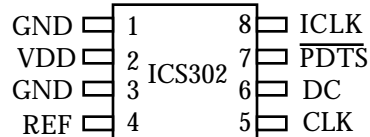
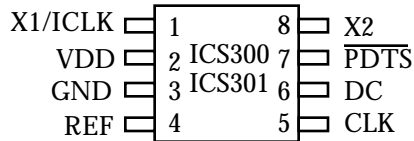

REF Clock Options

REF	Comments
Reference	Buffered oscillator output
Reference/2	Oscillator frequency divided by two
CLK/2	CLK frequency divided by two
Off	Output stopped low. Lowest jitter

Pin Descriptions

Number	Number	Name	Type	Description
300/1	302			
1	8	X1/ICLK	I	Crystal connection or clock input. Clock only on ICS302.
2	2	VDD	P	Connect to +3.3V or +5V.
3	1, 3	GND	P	Connect to ground.
4	4	REF	O	Buffered crystal oscillator output clock, or variation per REF clock options table above.
5	5	CLK	O	Clock output. Fixed frequency between 6 and 200 MHz programmed at factory.
6	6	DC	-	Don't Connect anything to this pin.
7	7	P̄DTS	I	Powers down PLL, and puts both outputs into high impedance state, when low.
8	-	X2	O	Crystal connection. Leave unconnected for clock input.

Key: I = Input, O = output, P = power supply connection

Device Configuration

The specification is complete when the ICS300/301/302 QTClock Order Form accompanies this data sheet. The order form lists the input, REF, and CLK actual frequencies, as well as any other available options. This unique configuration is given a two character alphanumeric programming code, which must be specified when referring to samples.

External Components / Crystal Selection

The ICS300/301/302 requires a 0.01μF decoupling capacitor to be connected between VDD and GND. It must be connected close to the ICS300/301/302 to minimize lead inductance. No external power supply filtering is required for this device. A 33Ω terminating resistor can be used next to the CLK and REF pins. The total on-chip capacitance is approximately 16 pF, so a parallel resonant, fundamental mode crystal should be used. For crystals with a specified load capacitance greater than 16 pF, crystal capacitors can be connected from each of the pins X1 and X2 to Ground. The value (in pF) of these crystal caps should be = $(C_L - 16) * 2$, where C_L is the crystal load capacitance in pF. These external capacitors are only required for applications where the exact frequency is critical. For a clock input, connect to X1/ICLK and leave X2 unconnected (no capacitors on either).



ICS300/ICS301/ICS302 QTClock™ Quick Turn Clock Synthesizer

Electrical Specifications

Parameter	Conditions	Minimum	Typical	Maximum	Units
ABSOLUTE MAXIMUM RATINGS (stresses beyond these can permanently damage the device)					
Supply Voltage, VDD	Referenced to GND			7	V
Inputs	Referenced to GND	-0.5		VDD+0.5	V
Clock Output	Referenced to GND	-0.5		VDD+0.5	V
Ambient Operating Temperature		0		70	°C
Soldering Temperature	Max of 10 seconds			260	°C
Storage temperature		-65		150	°C
DC CHARACTERISTICS (VDD = 5.0V unless otherwise noted)					
Operating Voltage, VDD		3		5.5	V
Input High Voltage, VIH, ICLK only	ICLK (Pin 1)	(VDD/2)+1	VDD/2		V
Input Low Voltage, VIL, ICLK only	ICLK (Pin 1)		VDD/2	(VDD/2)-1	V
Input High Voltage, VIH	$\overline{\text{PDT}}\overline{\text{S}}$	2			V
Input Low Voltage, VIL	$\overline{\text{PDT}}\overline{\text{S}}$			0.4	V
Output High Voltage, VOH	IOH=-4mA	VDD-0.4			V
Output High Voltage, VOH	IOH=-25mA	2.4			V
Output Low Voltage, VOL	IOL=25mA			0.4	V
IDD Operating Supply Current, 20 MHz crystal	No Load, 100MHz		20		mA
Short Circuit Current	CLK output		±70		mA
On-Chip Pull-up Resistor, $\overline{\text{PDT}}\overline{\text{S}}$	Pin 7		270		k
Input Capacitance, $\overline{\text{PDT}}\overline{\text{S}}$	Pin 7		4		pF
AC CHARACTERISTICS (VDD = 5.0V unless otherwise noted)					
Input Frequency, crystal input, ICS300 and 301		5		27	MHz
Input Frequency, clock input, ICS300 and 301		2		50	MHz
Input Frequency, clock input, ICS302		50		125	MHz
Output Frequency, ICS300	VDD = 4.5 to 5.5V	6		160	MHz
Output Frequency, ICS300	VDD = 3.0 to 3.6V	6		100	MHz
Output Frequency, ICS301 and ICS302	VDD = 4.5 to 5.5V	6		200	MHz
Output Frequency, ICS301 and ICS302	VDD = 3.0 to 3.6V	6		200	MHz
Output Clock Rise Time	0.8 to 2.0V		1		ns
Output Clock Fall Time	2.0 to 0.8V		1		ns
Output Clock Duty Cycle (Note 1)	at programmed level	45	49 to 51	55	%
Absolute Clock Period Jitter	Deviation from mean		±120		ps
One Sigma Clock Period Jitter			50		ps
Power-up time, $\overline{\text{PDT}}\overline{\text{S}}$ goes high until Refer. out	Reference on REF clk		3	10	ms
Power-up time, $\overline{\text{PDT}}\overline{\text{S}}$ goes high until CLK out			8	20	ms

Note 1: These are typical values. The actual minimum and maximum duty cycle limits are shown on the ICS300/301/302 QTClock Order Form for each programmed version.



ICS300/ICS301/ICS302 QTClock™ Quick Turn Clock Synthesizer

Package Outline and Package Dimensions

(For current dimensional specifications, see JEDEC Publication No. 95.)

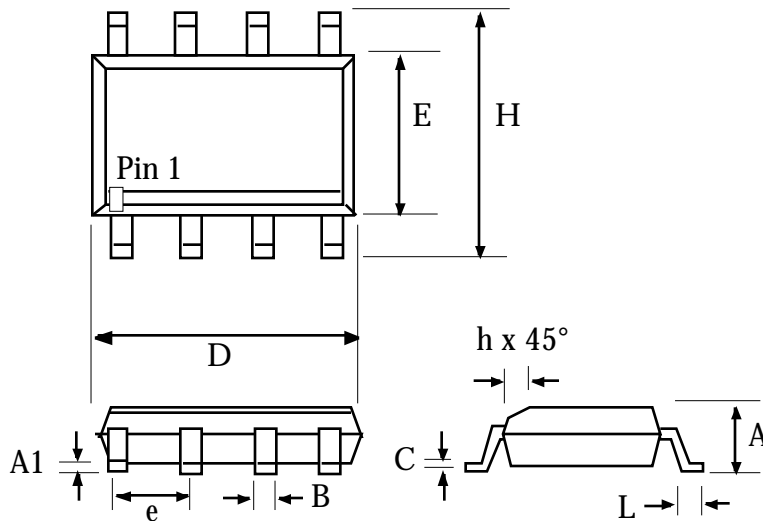

8 pin SOIC

Symbol	Inches		Millimeters	
	Min	Max	Min	Max
A	0.0532	0.0688	1.35	1.75
A1	0.0040	0.0098	0.10	0.24
B	0.0130	0.0200	0.33	0.51
C	0.075	0.098	1.91	2.40
D	0.1890	0.1968	4.80	5.00
E	0.1497	0.1574	3.80	4.00
e	.050 BSC		1.27 BSC	
H	0.2284	0.2440	5.80	6.20
h	0.0099	0.0195	0.25	0.50
L	0.0160	0.0500	0.41	1.27

Ordering Information

Part/Order Number	Marking	Package	Temperature
ICS300M-xx	ICS300M	8 pin SOIC	0 to 70 °C
ICS300MT-xx	ICS300M	8 pin SOIC on tape and reel	0 to 70 °C
ICS301M-xx	ICS301M	8 pin SOIC	0 to 70 °C
ICS301MT-xx	ICS301M	8 pin SOIC on tape and reel	0 to 70 °C
ICS302M-xx	ICS302M	8 pin SOIC	0 to 70 °C
ICS302MT-xx	ICS302M	8 pin SOIC on tape and reel	0 to 70 °C

xx represents a 2 character alphanumeric programming code assigned by the factory, which indicates the output frequencies on CLK and REF. All samples are shipped with an ICS300/301/302 order form describing the characteristics of the device.

While the information presented herein has been checked for both accuracy and reliability, Integrated Circuit Systems, Inc. (ICS) assumes no responsibility for either its use or for the infringement of any patents or other rights of third parties, which would result from its use. No other circuits, patents, or licenses are implied. This product is intended for use in normal commercial applications. Any other applications such as those requiring extended temperature range, high reliability, or other extraordinary environmental requirements are not recommended without additional processing by ICS. ICS reserves the right to change any circuitry or specifications without notice. ICS does not authorize or warrant any ICS product for use in life support devices or critical medical instruments.

QTClock is a trademark of ICS