

Wideband Four Quadrant Analog Multiplier (Current Output)

July 1994

Features

- This Circuit is Processed in Accordance to MIL-STD-883 and is Fully Conformant Under the Provisions of Paragraph 1.2.1.
- Low Multiplication Error 1.5% (Typ)
- Input Bias Currents 8 μ A (Typ)
- Signal Input Feedthrough at 5MHz. -52dB (Typ)
- Wide Y Channel Bandwidth 130MHz (Typ)
- Wide X Channel Bandwidth 75MHz (Typ)
- Rise Time ($R_L = 50\Omega$) 7ns (Typ)
- Supply Current..... 17mA (Max)

Applications

- Military Avionics
- Missile Guidance Systems
- Medical Imaging Displays
- Video Mixers
- Sonar AGC Processors
- Radar Signal Conditioning
- Voltage Controlled Amplifier
- Vector Generator

Description

The HA-2557/883 is a monolithic, high speed, four quadrant, analog multiplier constructed in Intersil' Dielectrically Isolated High Frequency Process. The single-ended current output of the HA-2557/883 has a 130MHz signal bandwidth ($R_L = 50\Omega$). High bandwidth and low distortion make this part an ideal component in video systems.

The suitability for precision video applications is demonstrated further by low multiplication error (1.5%), low feedthrough (-52dB), and differential inputs with low bias currents (8 μ A). The HA-2557/883 is also well suited for mixer circuits as well as AGC applications for sonar, radar, and medical imaging equipment.

The current output of the HA-2557/883 allows it to achieve higher bandwidths than voltage output multipliers. Full scale output current is trimmed to 1.6mA. An internal 2500 Ω feedback resistor is also provided to accurately convert the current, if desired, to a full scale output voltage of $\pm 4V$. The HA-2557/883 is not limited to multiplication applications only; frequency doubling, power detection, as well as many other configurations are also possible.

Ordering Information

PART NUMBER	TEMPERATURE RANGE	PACKAGE
HA1-2557/883	-55°C to +125°C	16 Lead CerDIP

Pinout

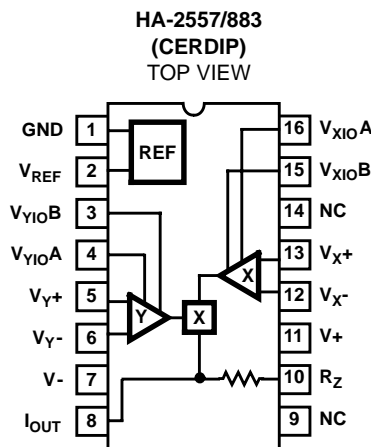

Schematic

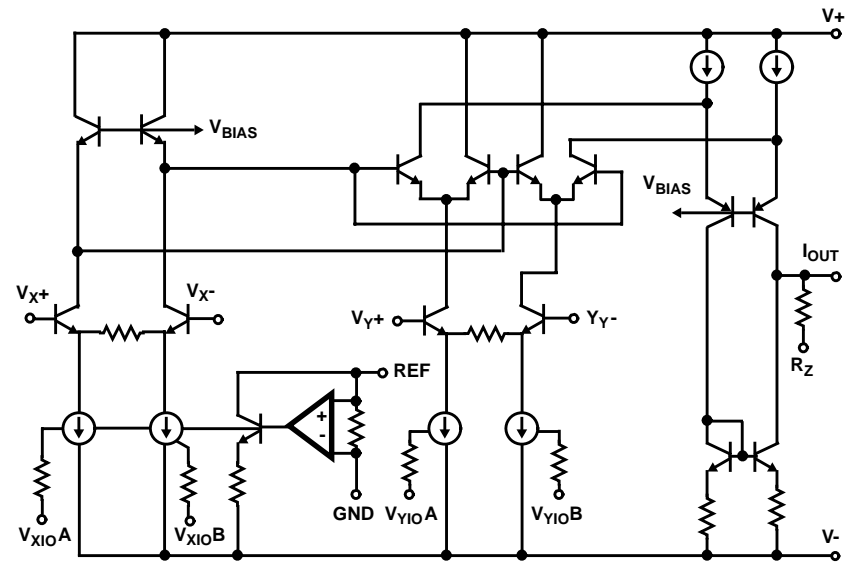

Specifications HA2557/883

Absolute Maximum Ratings

Voltage Between V+ and V-	35V
Differential Input Voltage	6V
Output Current	±3mA
ESD Rating	< 2000V
Lead Temperature (Soldering 10s)	+300°C
Storage Temperature Range	-65°C ≤ T _A ≤ +150°C
Max Junction Temperature	+175°C

Thermal Information

Thermal Resistance	θ_{JA}	θ_{JC}
CerDIP Package	82°C/W	27°C/W
Maximum Package Power Dissipation at +75°C		
CerDIP Package		1.22W
Package Power Dissipation Derating Factor above +75°C		
CerDIP Package		12mW/°C

CAUTION: Stresses above those listed in "Absolute Maximum Ratings" may cause permanent damage to the device. This is a stress only rating and operation of the device at these or any other conditions above those indicated in the operational sections of this specification is not implied.

Operating Conditions

Operating Supply Voltage (±V _S)	±15V	Operating Temperature Range	-55°C ≤ T _A ≤ +125°C
---	------	-----------------------------	---------------------------------

TABLE 1. DC ELECTRICAL PERFORMANCE CHARACTERISTICS

Device Tested at: V_{SUPPLY} = ±15V, R_Z (Pin 10) not connected, Unless Otherwise Specified.

PARAMETERS	SYMBOL	CONDITIONS	GROUP A SUBGROUPS	TEMPERATURE	LIMITS		UNITS
					MIN	MAX	
Multiplication Error	ME	V _Y , V _X = ±4V FS = 1.6mA	1	+25°C	-3	3	%FS
			2, 3	+125°C, -55°C	-6	6	%FS
Linearity Error	LE	V _Y , V _X = ±4V	1	+25°C	-0.25	0.25	%FS
R _Z Accuracy	RZE	Nominal 2500Ω	1	+25°C	-3	3	%
			2, 3	+125°C, -55°C	-5	5	%
I _{OUT} Offset	I _{OO}	V _X , V _Y = 0V	1	+25°C	-10	10	μA
			2, 3	+125°C, -55°C	-15	15	μA
Input Offset Voltage (V _X)	V _{XIO}	V _Y = ±4V	1	+25°C	-15	15	mV
			2, 3	+125°C, -55°C	-25	25	mV
Input Bias Current (V _X)	I _B (V _X)	V _X = 0V, V _Y = 4V	1	+25°C	-15	15	μA
			2, 3	+125°C, -55°C	-25	25	μA
Input Offset Current (V _X)	I _{IO} (V _X)	V _X = 0V, V _Y = 4V	1	+25°C	-2	2	μA
			2, 3	+125°C, -55°C	-3	3	μA
Common Mode (V _X) Rejection Ratio	CMRR(V _X)	V _{XCM} = ±10V V _Y = 4V	1	+25°C	65	-	dB
			2, 3	+125°C, -55°C	65	-	dB
Power Supply (V _X) Rejection Ratio	+ PSRR(V _X)	V ₊ = +12V to +17V V _Y = 4V	1	+25°C	65	-	dB
			2, 3	+125°C, -55°C	65	-	dB
	- PSRR(V _X)	V ₋ = -12V to -17V V _Y = 4V	1	+25°C	45	-	dB
			2, 3	+125°C, -55°C	45	-	dB
Input Offset Voltage (V _Y)	V _{YIO}	V _X = ±4V	1	+25°C	-15	15	mV
			2, 3	+125°C, -55°C	-25	25	mV
Input Bias Current (V _Y)	I _B (V _Y)	V _Y = 0V, V _X = 4V	1	+25°C	-15	15	μA
			2, 3	+125°C, -55°C	-25	25	μA
Input Offset Current (V _Y)	I _{IO} (V _Y)	V _Y = 0V, V _X = 4V	1	+25°C	-2	2	μA
			2, 3	+125°C, -55°C	-3	3	μA
Common Mode (V _Y) Rejection Ratio	CMRR(V _Y)	V _{YCM} = +9V, -10V V _X = 4V	1	+25°C	65	-	dB
			2, 3	+125°C, -55°C	65	-	dB
Power Supply (V _Y) Rejection Ratio	+ PSRR(V _Y)	V ₊ = +12V to +17V V _X = 4V	1	+25°C	65	-	dB
			2, 3	+125°C, -55°C	65	-	dB
	- PSRR(V _Y)	V ₋ = -12V to -17V V _X = 4V	1	+25°C	45	-	dB
			2, 3	+125°C, -55°C	45	-	dB
Supply Current	I _{CC}	V _X , V _Y = 0V	1	+25°C	-	17	mA
			2, 3	+125°C, -55°C	-	17	mA
Output Impedance	Z _{OUT}	V _{OUT} = ±10V	1	+25°C	1.0	-	MΩ

TABLE 2. AC ELECTRICAL PERFORMANCE CHARACTERISTICS

Table 2 Intentionally Left Blank. See AC Specifications in Table 3

TABLE 3. ELECTRICAL PERFORMANCE CHARACTERISTICS

Device Tested at: $V_{SUPPLY} = \pm 15V$, R_Z (Pin 10) not connected, Unless Otherwise Specified.

PARAMETERS	SYMBOL	CONDITIONS	NOTES	TEMPERATURE	LIMITS		UNITS
					MIN	MAX	
V_Y CHARACTERISTICS							
Bandwidth	$BW(V_Y)$	-3dB, $V_X = 4V$, $V_Y \leq 200mV_{P-P}$	1	+25°C	90	-	MHz
AC Feedthrough	V_{ISO}	$f_O = 5MHz$, $V_Y = 200mV_{P-P}$ $V_X = Nulled$	1, 2	+25°C	-	-48	dB
Rise and Fall Time	T_R, T_F	$V_Y = -4V$ to +4V Step $V_X = 4V$, 10% to 90% pts	1	+25°C	-	10	ns
Overshoot	+OS, -OS	$V_Y = -4V$ to +4V Step $V_X = 4V$	1	+25°C	-	10	%
Differential Input Resistance	$R_{IN}(V_Y)$	$V_Y = \pm 4V$, $V_X = 0V$	1	+25°C	650	-	kΩ
V_X CHARACTERISTICS							
Bandwidth	$BW(V_X)$	-3dB, $V_Y = 4V$, $V_X \leq 200mV_{P-P}$	1	+25°C	60	-	MHz
AC Feedthrough	V_{ISO}	$f_O = 5MHz$, $V_X = 200mV_{P-P}$ $V_Y = Nulled$	1, 2	+25°C	-	-50	dB
Rise and Fall Time	T_R, T_F	$V_X = -4V$ to +4V Step $V_Y = 4V$, 10% to 90% pts	1	+25°C	-	10	ns
Overshoot	+OS, -OS	$V_X = -4V$ to +4V Step $V_Y = 4V$	1	+25°C	-	15	%
Differential Input Resistance	$R_{IN}(V_X)$	$V_X = \pm 4V$, $V_Y = 0V$	1	+25°C	650	-	kΩ

NOTE:

- Parameters listed in Table 3 are controlled via design or process parameters and are not directly tested at final production. These parameters are lab characterized upon initial design release, or upon design changes. These parameters are guaranteed by characterization based upon data from multiple production runs which reflect lot to lot and within lot variation.
- Offset voltage applied to minimize feedthrough signal.

TABLE 4. ELECTRICAL TEST REQUIREMENTS

MIL-STD-883 TEST REQUIREMENTS	SUBGROUPS (SEE TABLE 1)
Interim Electrical Parameters (Pre Burn-In)	-
Final Electrical Test Parameters	1 (Note 1), 2, 3
Group A Test Requirements	1, 2, 3
Groups C and D Endpoints	1

NOTE:

- PDA applies to Subgroup 1 only.

Die Characteristics

DIE DIMENSIONS:

71mils x 100mils x 19mils ± 1mils

METALLIZATION:

Type: Al, 1% Cu
 Thickness: $16k\text{\AA} \pm 2k\text{\AA}$

GLASSIVATION:

Type: Nitride (Si_3N_4) over Silox (SiO_2 , 5% Phos)
 Silox Thickness: $12k\text{\AA} \pm 2k\text{\AA}$
 Nitride Thickness: $3.5k\text{\AA} \pm 1.5k\text{\AA}$

TRANSISTOR COUNT: 72

SUBSTRATE POTENTIAL: V-

WORST CASE CURRENT DENSITY:

$0.47 \times 10^5 \text{A/cm}^2$

Metallization Mask Layout

HA-2557/883

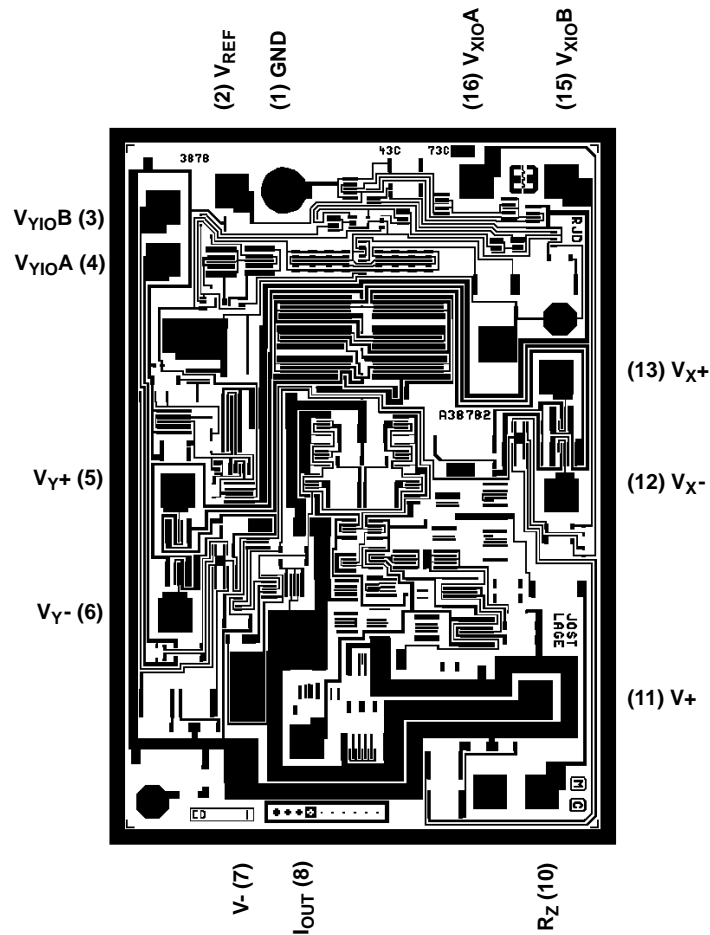

Test Circuits

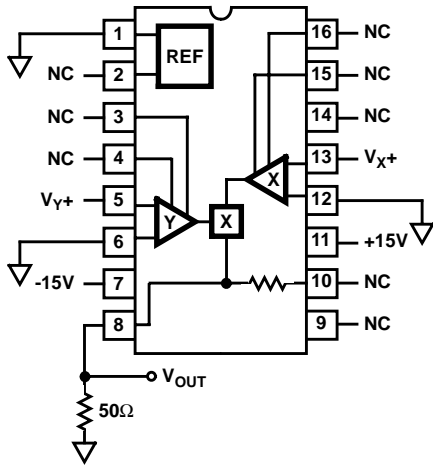

V_Y TRANSIENT RESPONSE
 Vertical Scale: Top 5V/Div. Bottom: 100mV/Div.
 Horizontal Scale: 20ns/Div.

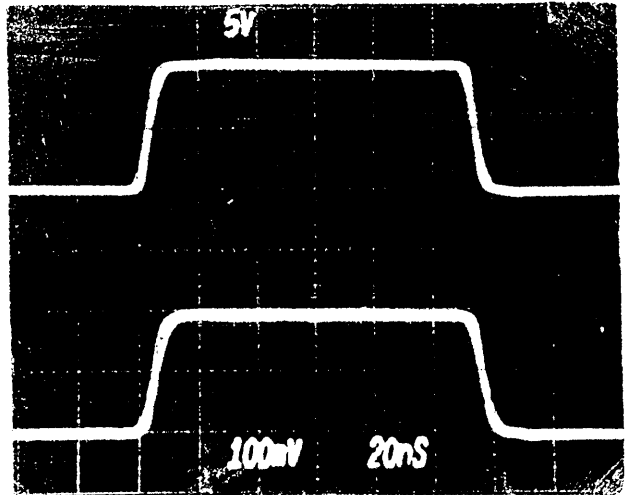
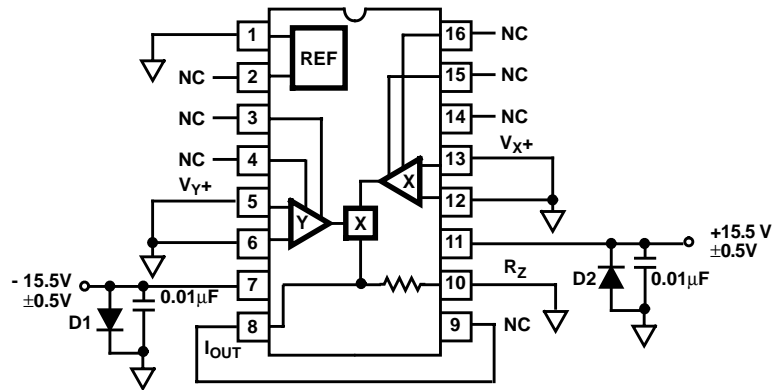

FIGURE 1. AC AND TRANSIENT RESPONSE TEST CIRCUIT

Burn-In Circuit

HA-2557/883 CERAMIC DIP



D1 = D2 = 1N4002 OR EQUIVALENT (PER BOARD)

Packaging

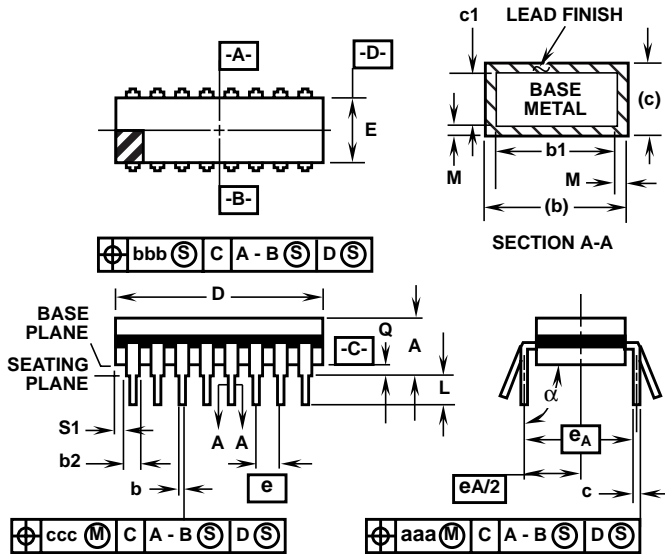

**F16.3 MIL-STD-1835 GDIP1-T16 (D-2, CONFIGURATION A)
16 LEAD DUAL-IN-LINE FRIT-SEAL CERAMIC PACKAGE**

SYMBOL	INCHES		MILLIMETERS		NOTES
	MIN	MAX	MIN	MAX	
A	-	0.200	-	5.08	-
b	0.014	0.026	0.36	0.66	2
b1	0.014	0.023	0.36	0.58	3
b2	0.045	0.065	1.14	1.65	-
b3	0.023	0.045	0.58	1.14	4
c	0.008	0.018	0.20	0.46	2
c1	0.008	0.015	0.20	0.38	3
D	-	0.840	-	21.34	5
E	0.220	0.310	5.59	7.87	5
e	0.100 BSC		2.54 BSC		-
eA	0.300 BSC		7.62 BSC		-
eA/2	0.150 BSC		3.81 BSC		-
L	0.125	0.200	3.18	5.08	-
Q	0.015	0.060	0.38	1.52	6
S1	0.005	-	0.13	-	7
S2	0.005	-	0.13	-	-
α	90°	105°	90°	105°	-
aaa	-	0.015	-	0.38	-
bbb	-	0.030	-	0.76	-
ccc	-	0.010	-	0.25	-
M	-	0.0015	-	0.038	2
N	16		16		8

NOTES:

1. Index area: A notch or a pin one identification mark shall be located adjacent to pin one and shall be located within the shaded area shown. The manufacturer's identification shall not be used as a pin one identification mark.
2. The maximum limits of lead dimensions b and c or M shall be measured at the centroid of the finished lead surfaces, when solder dip or tin plate lead finish is applied.
3. Dimensions b1 and c1 apply to lead base metal only. Dimension M applies to lead plating and finish thickness.
4. Corner leads (1, N, N/2, and N/2+1) may be configured with a partial lead paddle. For this configuration dimension b3 replaces dimension b1.
5. This dimension allows for off-center lid, meniscus, and glass overrun.
6. Dimension Q shall be measured from the seating plane to the base plane.
7. Measure dimension S1 at all four corners.
8. N is the maximum number of terminal positions.
9. Dimensioning and tolerancing per ANSI Y14.5M - 1982.
10. Controlling Dimension: Inch.
11. Lead Finish: Type A.
12. Materials: Compliant to MIL-M38510.

DESIGN INFORMATION

August 1999

Wideband Four Quadrant Current Output Analog Multiplier

The information contained in this section has been developed through characterization by Intersil Semiconductor and is for use as application and design information only. No guarantee is implied.

Typical Performance Curves

V_Y BANDWIDTH

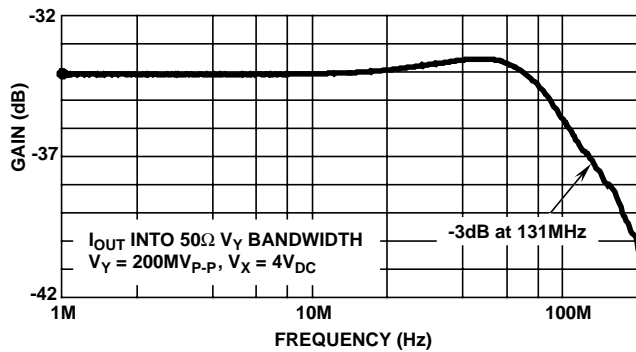

V_X BANDWIDTH

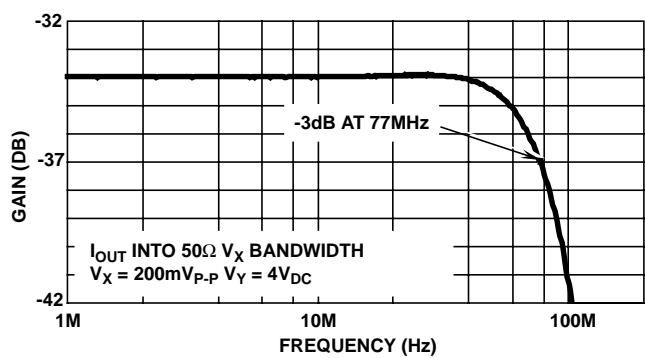

HA2557 INTO HA2842 AS I TO V CONVERTER V_Y FULLPOWER BANDWIDTH

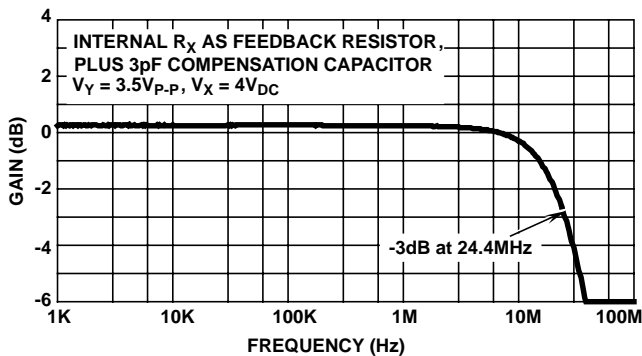

V_Y TRANSIENT RESPONSE OF HA-2842 AS I TO V CONVERTER

Top: V_Y Input 0 to 4V Step
Bottom: HA-2842 0 to 4V Response

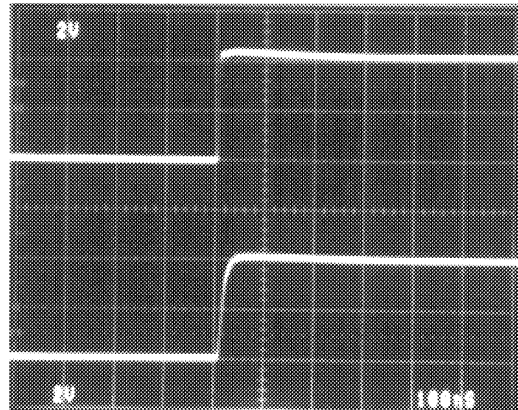

DESIGN INFORMATION (Continued)

The information contained in this section has been developed through characterization by Intersil Semiconductor and is for use as application and design information only. No guarantee is implied.

Typical Performance Curves

DRIVING HA5023 AS I TO V CONVERTER V_Y BANDWIDTH

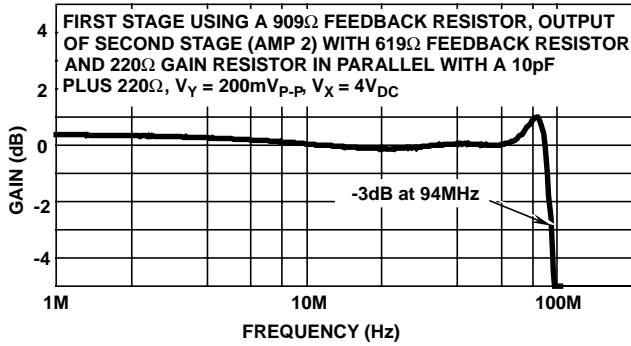

V_Y TRANSIENT RESPONSE OF HA5023 AS I TO V CONVERTER

Top: V_Y Input 0 to 4V Step
Bottom: HA5023 0 to 4V Response

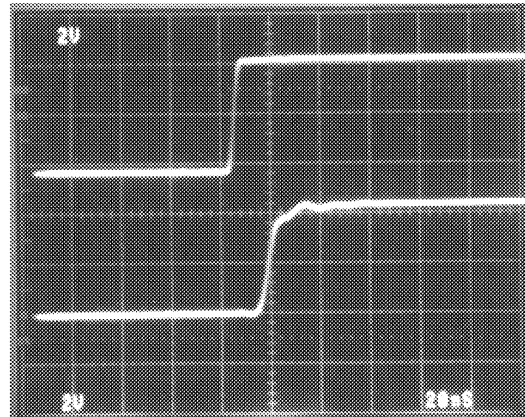

DRIVING HA5023 AS I TO V CONVERTER V_X BANDWIDTH

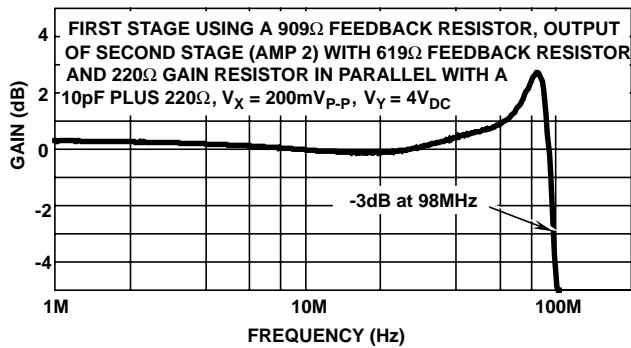

V_X TRANSIENT RESPONSE OF HA5023 AS I TO V CONVERTER

Top: V_X Input 0 to 4V Step
Bottom: HA5023 0 to 4V Response

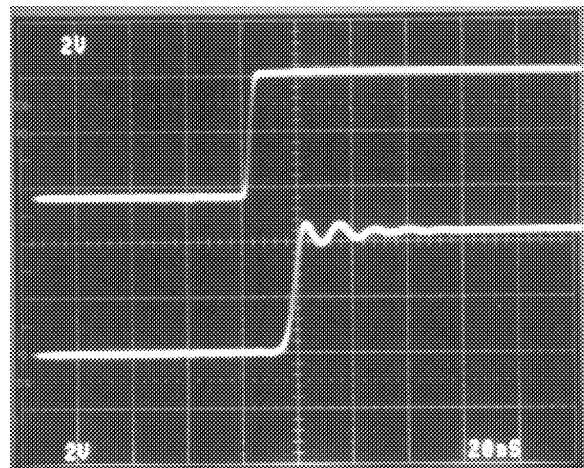

DRIVING HA5023 AS I TO V CONVERTER V_Y FULLPOWER BANDWIDTH

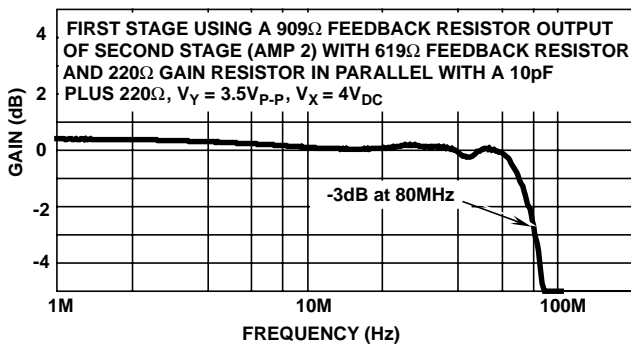

DRIVING HA5023 AS I TO V CONVERTER V_X FULLPOWER BANDWIDTH

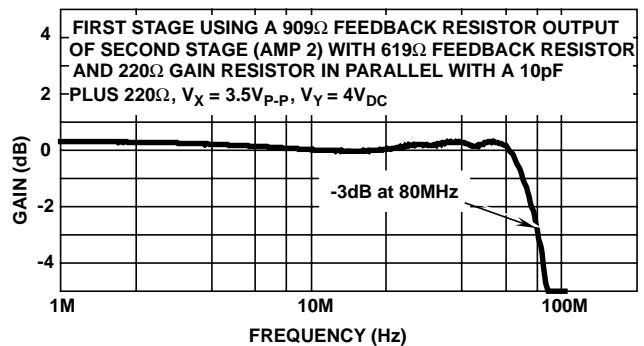

DESIGN INFORMATION (Continued)

The information contained in this section has been developed through characterization by Intersil Semiconductor and is for use as application and design information only. No guarantee is implied.

Typical Performance Curves

INPUT BIAS CURRENT

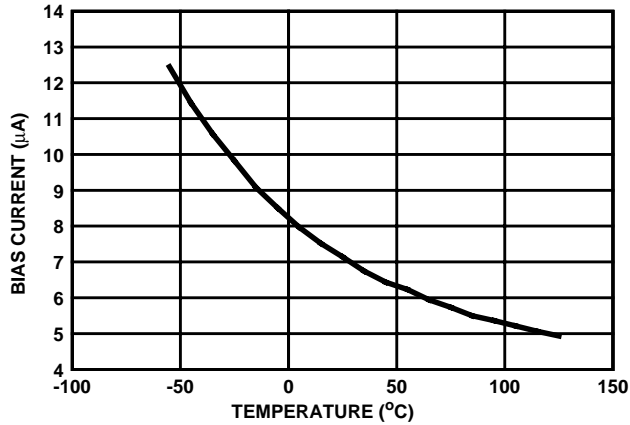

ABSOLUTE VALUE OFFSET VOLTAGE

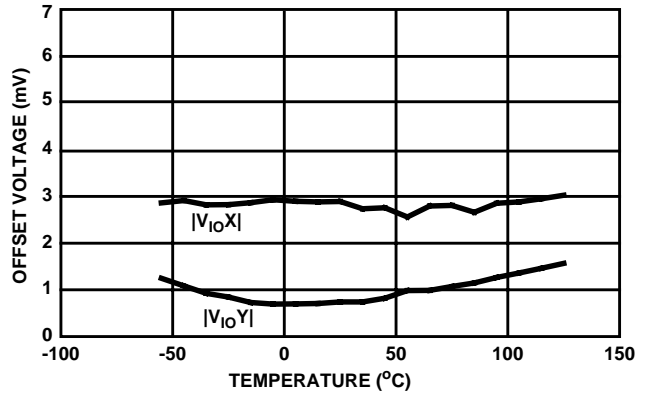

SCALE FACTOR ERROR

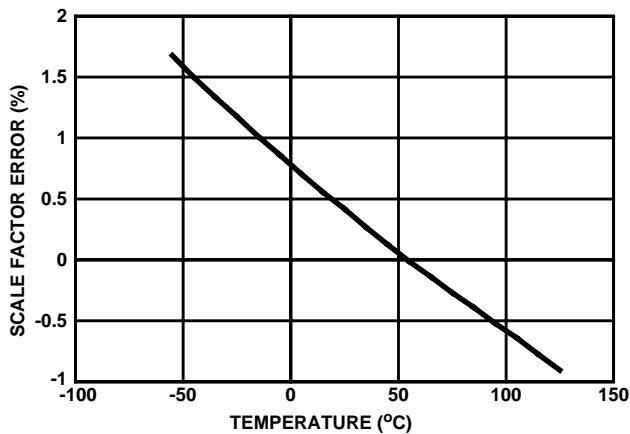

INPUT VOLTAGE RANGE

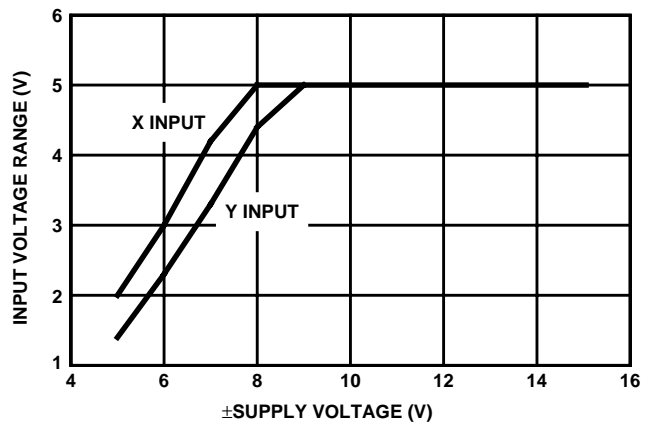

INPUT COMMON MODE RANGE

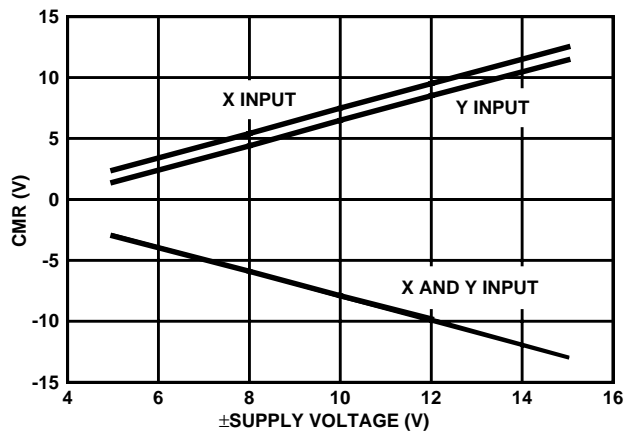

DESIGN INFORMATION (Continued)

The information contained in this section has been developed through characterization by Intersil Semiconductor and is for use as application and design information only. No guarantee is implied.

Applications Information

Operation at Reduced Supply Voltages

The HA-2557 will operate over a range of supply voltages, $\pm 5V$ to $\pm 15V$. Use of supply voltages below $\pm 12V$ will reduce input and output voltage ranges. See "Typical Performance Curves" for more information.

Offset Adjustment

The channel offset voltage may be nulled by using a 20K potentiometer between the V_{YIO} or V_{XIO} adjust pin A and B and connecting the wiper to V_- . Reducing the channel offset voltage will reduce AC feedthrough and improve the multiplication error.

Theory of Operation

The HA-2557 creates an output current that is the product of the X and Y input voltages divided by a constant scale factor of $10kV\Omega$. The resulting output has the correct polarity in each of the four quadrants defined by the combinations of positive and negative X and Y inputs. This results in the following equation, where X and Y are high impedance differential inputs:

$$I_{OUT} = \frac{X \times Y}{10kV\Omega}$$

To accomplish this the differential input voltages are first converted into differential currents by the X and Y input transconductance stages. The currents are then scaled by a constant reference and combined in the multiplier core. The multiplier core is a basic Gilbert Cell that produces a differential output current proportional to the product of X and Y input signal currents. This current is converted into the output for the HA-2557.

The purpose of the reference circuit is to provide a stable current, used in setting the scale factor. This is achieved with a bandgap reference circuit to produce a temperature stable voltage of 1.2V which is forced across a NiCr resistor. Slight adjustments to scale factor may be possible by overriding the internal reference with the V_{REF} pin. The scale factor is used to maintain the output of the multiplier within the normal operating range of $\pm 1.6mA$ when full scale inputs are applied.

Communications

The multiplier function of the HA-2557 has applications in AM Signal Generation, Synchronous AM Detection and Phase Detection. These circuit configurations are shown in Figure 2, Figure 3 and Figure 4. By feeding a signal into both X and Y inputs a Square function results that is useful as a Frequency Doubler as shown in Figure 5. The HA-2557 is particularly useful in applications that require the interaction of high speed signals. Both inputs X and Y have similar wide bandwidth and input characteristics. This is unlike earlier

products where one input was dedicated to a slow moving control function as is required for Automatic Gain Control. The HA-2557 is versatile enough for both.

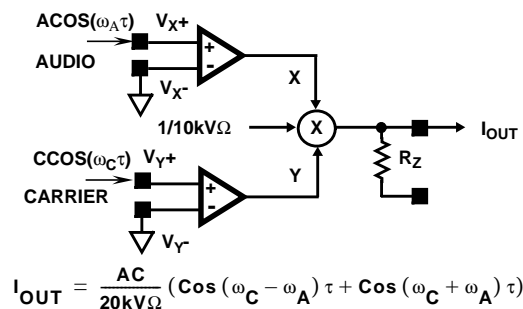

$$I_{OUT} = \frac{AC}{20kV\Omega} (\cos(\omega_C - \omega_A)\tau + \cos(\omega_C + \omega_A)\tau)$$

FIGURE 2. AM SIGNAL GENERATION

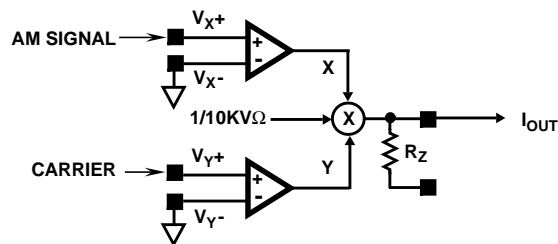

LIKE THE FREQUENCY DOUBLER YOU GET AUDIO CENTERED AT DC AND $2F_C$.

FIGURE 3. SYNCHRONOUS AM DETECTION

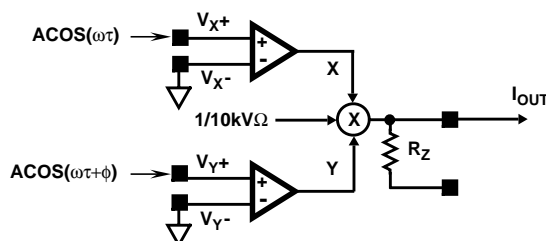

$$I_{OUT} = \frac{A^2}{20kV\Omega} (\cos(\phi) + \cos(2\omega\tau + \phi))$$

DC COMPONENT IS PROPORTIONAL TO $\cos(\phi)$

FIGURE 4. PHASE DETECTION

DESIGN INFORMATION (Continued)

The information contained in this section has been developed through characterization by Intersil Semiconductor and is for use as application and design information only. No guarantee is implied.

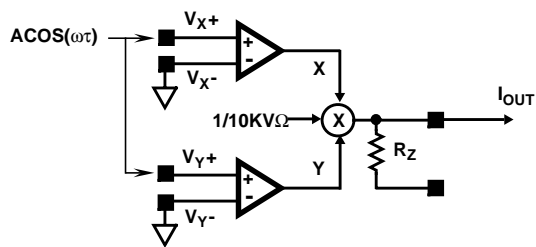

$$(A \cos(\omega\tau) \times A \cos(\omega\tau)) = 10kV\Omega (I_{OUT})$$

WHICH EVALUATES TO:

$$I_{OUT} = \frac{A^2}{20K} (1 + \cos(2\omega\tau))$$

FIGURE 5. FREQUENCY DOUBLER

Although the X and Y inputs have similar AC characteristics, they are not the same. The designer should consider input parameters such as small signal bandwidth and ac feedthrough to get the most performance from the HA-2557. The Y channel is the faster of the two inputs with a small signal bandwidth of typically 130MHz versus 75MHz for the X channel. Therefore in AM Signal Generation, the best performance will be obtained with the Carrier applied to the Y channel and the modulation signal (lower frequency) applied to the X channel.

Operation Over a Wide Supply Range

The HA-2557 is able to operate over a wide supply voltage range $\pm 5V$ to $\pm 17.5V$. The $\pm 5V$ range is particularly useful in video applications. At $\pm 5V$ the input voltage range is reduced to $\pm 1.4V$ limiting the fullscale output current. Another current output option is the HA-2556 voltage output multiplier configured for current output with an output sensing resistor (Refer to the HA-2556 datasheet).

Automatic Gain Control

Figure 6 shows the HA-2557 configured in an Automatic Gain Control or AGC application. The HA-2842 serves as an output I to V converter using R_Z which is trimmed to provide an accurate 4V Fullscale conversion. Refer to **Voltage Output Conversion** for more details about this function. The HA-5127 low noise amplifier provides the gain control signal to the X input. This control signal sets the peak output voltage of the multiplier to match the preset reference level. The feedback network around the HA-5127 provides a response time adjustment. High frequency changes in the peak are rejected as noise or the desired signal to be transmitted. These signals do not indicate a change in the average peak value and therefore no gain adjustment is needed. Lower frequency changes in the peak value are given a gain of -1 for feedback to the control input. At DC the circuit is an integrator automatically compensating for offset and other constant error terms.

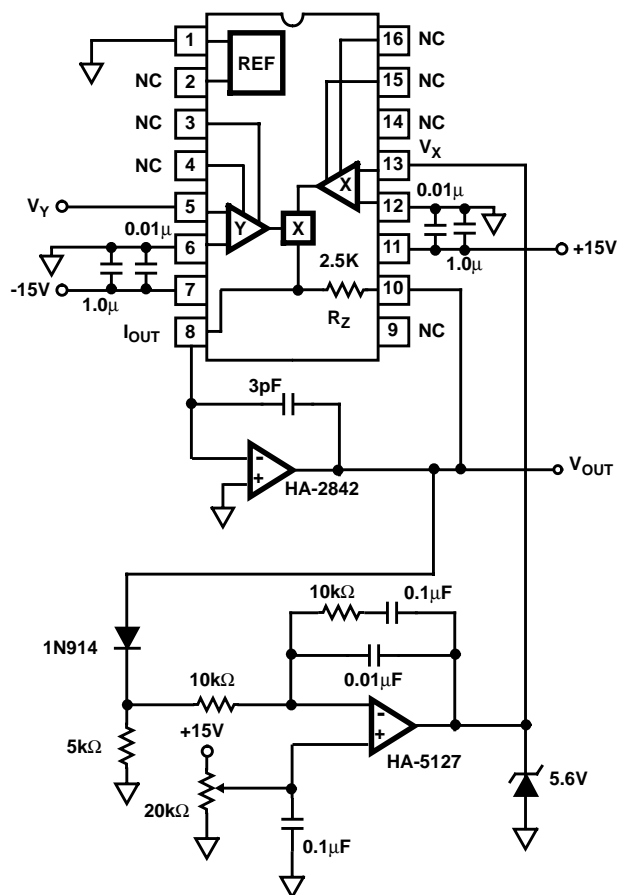

FIGURE 6. AUTOMATIC GAIN CONTROL

This multiplier has the advantage over other AGC circuits, in that the signal bandwidth is not affected by the control signal gain adjustment.

Voltage Output Conversion

The HA-2842 is an excellent choice to perform the output current to voltage conversion as shown in Figure 7. The combination of $400V/\mu s$ slew rate and 80MHz Gain Bandwidth product will maintain signal dynamics while providing a full scale $\pm 4V$ output. The HA-2842 also provides a hefty output drive capability of 100mA.

This voltage feedback amplifier takes advantage of the internal R_Z resistor, trimmed to provide an accurate 4V fullscale conversion. The parasitic capacitance at the negative input of the HA-2842 must be compensated with a 3pF capacitor from pin 2 to pin 6. This compensation will also insure that the amp will see a noise gain of 2 at its crossover frequency, the minimum required for stability with this device. The full power bandwidth curve and large signal pulse response for this circuit are shown in Typical Performance Curves. The fast slew rate of the HA-2842 results in a minimal reduction of bandwidth for large signals.

DESIGN INFORMATION (Continued)

The information contained in this section has been developed through characterization by Intersil Semiconductor and is for use as application and design information only. No guarantee is implied.

Another choice for an I to V converter that takes better advantage of the wide bandwidth of the HA-2557, is to use the HA5023 Dual 100MHz current feedback amp. The optimum bandwidth of a current feedback amp is obtained with a fixed feedback resistor. Therefore scaling the I to V conversion to a convenient value requires two stages. Fortunately the HA5023 provides two wideband amplifiers in a single 8 pin Mini-DIP or SOIC package, while their current feedback architecture provides signal gain with minimal reduction in bandwidth. This circuit configuration is shown in Figure 8.

The optimum bandwidth is achieved in stage 1 with a 909Ω feedback resistor. This voltage is then gained up by the second stage to provide a ±4V Fullscale Voltage output with a bandwidth in excess of 90MHz. The 10pF capacitor and the additional 220Ω resistor improve gain flatness and reduce gain peaking. The HA5023 also provides excellent Full Power Bandwidth (-3dB at 80MHz for a 3.5V_{P-P} signal). Refer to Typical Performance Curves for more information.

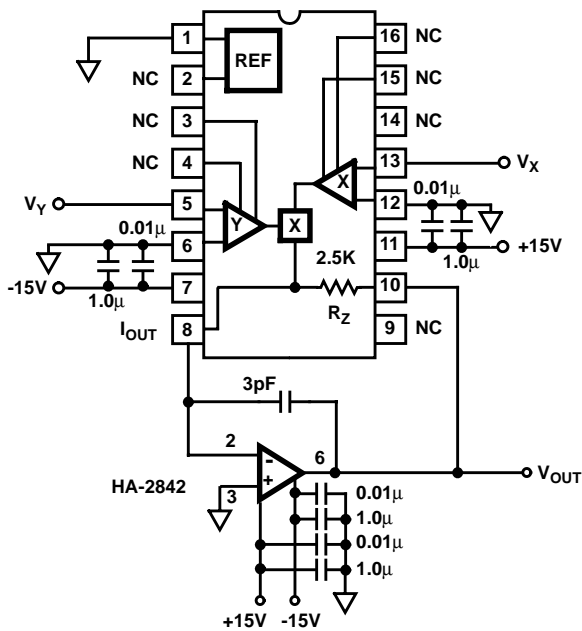

FIGURE 7. VOLTAGE OUTPUT CONVERSION

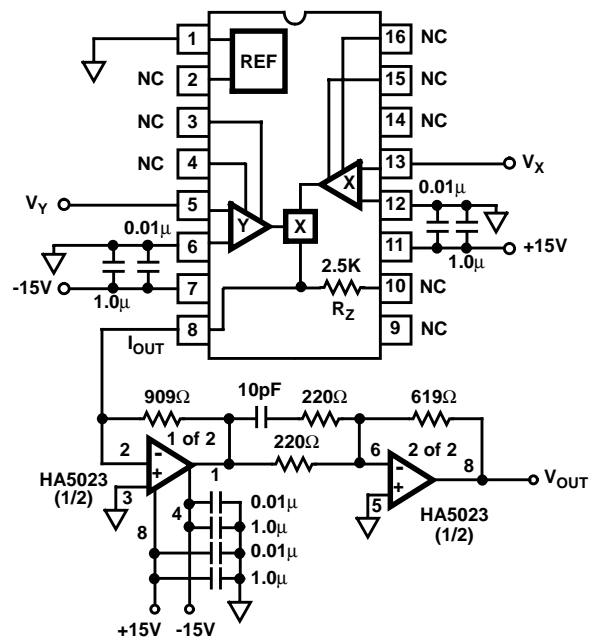

FIGURE 8. VOLTAGE OUTPUT CONVERSION

DESIGN INFORMATION (Continued)

The information contained in this section has been developed through characterization by Intersil Semiconductor and is for use as application and design information only. No guarantee is implied.

TYPICAL PERFORMANCE CHARACTERISTICS

Device Tested at $V_{\text{SUPPLY}} = 15\text{V}$, R_Z (Pin 10) Not Connected, Unless Otherwise Specified.

PARAMETERS	SYMBOL	CONDITIONS	TEMPERATURE	TYPICAL	UNITS
Multiplication Error	ME	$V_Y, V_X = \pm 4\text{V}$	+25°C	±1.5	%FS
			+125°C, -55°C	±3.0	%FS
Multiplication Error Drift	METC	$V_Y, V_X = \pm 4\text{V}$	+125°C, -55°C	±0.003	%FS/°C
Linearity Error	LE3V	$V_Y, V_X = \pm 3\text{V}$	+25°C	±0.02	%FS
	LE4V	$V_Y, V_X = \pm 4\text{V}$	+25°C	±0.05	%FS
Scale Factor	SF		+25°C	10	kVΩ
Voltage Noise	$E_N(1\text{kHz})$	$f = 1\text{kHz}, V_X = 0\text{V}, V_Y = 0\text{V}$	+25°C	150	nV/√Hz
	$E_N(100\text{kHz})$	$f = 100\text{kHz}, V_X = 0\text{V}, V_Y = 0\text{V}$	+25°C	40	nV/√Hz
Positive Power Supply Rejection Ratio	+PSRR	$V_{S+} = +12\text{V to } +15\text{V},$ $V_{S-} = -15\text{V}$	+25°C	80	dB
			+125°C, -55°C	80	dB
Negative Power Supply Rejection Ratio	-PSRR	$V_{S-} = -12\text{V to } -15\text{V},$ $V_{S+} = +15\text{V}$	+25°C	55	dB
			+125°C, -55°C	55	dB
Supply Current	I_{CC}	$V_X, V_Y = 0\text{V}$	+25°C	13	mA
			+125°C, -55°C	13	mA
INPUT CHARACTERISTICS					
Input Offset Voltage	V_{IO}	$V_Y = \pm 4\text{V}$	+25°C	±4	mV
			+125°C, -55°C	±8	mV
Input Offset Voltage Drift	$V_{\text{IO}TC}$	$V_Y = \pm 4\text{V}$	+125°C, -55°C	±35	μV/°C
Input Bias Current	I_{B}	$V_X = 0\text{V}, V_Y = 4\text{V}$	+25°C	±8	μA
			+125°C, -55°C	±12	μA
Input Offset Current	I_{IO}	$V_X = 0\text{V}, V_Y = 4\text{V}$	+25°C	±0.5	μA
			+125°C, -55°C	±1.0	μA
Differential Input Range			+25°C	±4	V

DESIGN INFORMATION (Continued)

The information contained in this section has been developed through characterization by Intersil Semiconductor and is for use as application and design information only. No guarantee is implied.

TYPICAL PERFORMANCE CHARACTERISTICS

Device Tested at $V_{SUPPLY} = 15V$, R_Z (Pin 10) Not Connected, Unless Otherwise Specified.

PARAMETERS	SYMBOL	CONDITIONS	TEMPERATURE	TYPICAL	UNITS
V_Y CHARACTERISTICS					
Bandwidth	BW(V _Y)	-3dB, V _X = 4V, V _Y ≤ 200mV _{P-P}	+25°C	130	MHz
AC Feedthrough	V _{ISO} (5MHz)	f _O = 5MHz, V _Y = 200mV _{P-P} V _X = Nulled (Note 1)	+25°C	-52	dB
Rise and Fall Time	T _R , T _F	V _Y = -4V to +4V Step, V _X = 4V, 10% to 90% pts	+25°C	7	ns
Differential Input Resistance	R _{IN} (V _Y)	V _Y = ±4V, V _X = 0V	+25°C	1	MΩ
V_X CHARACTERISTICS					
Bandwidth	BW(V _X)	-3dB, V _Y = 4V, V _X ≤ 200mV _{P-P}	+25°C	75	MHz
AC Feedthrough	V _{ISO} (5MHz)	f _O = 5MHz, V _X = 200mV _{P-P} V _Y = nulled (Note 1)	+25°C	-54	dB
Rise and Fall Time	T _R , T _F	V _X = -4V to +4V step, V _Y = 4V, 10% to 90% pts	+25°C	7	ns
Differential Input Resistance	R _{IN} (V _X)	V _X = ±4V, V _Y = 0V	+25°C	1	MΩ
OUTPUT CHARACTERISTICS					
Output Offset Current	I _{OO}	V _X , V _Y = 0V	+25°C	2.4	μA
			+125°C, -55°C	5.6	μA
Full Scale Output Current	I _{OUT} FS	V _X , V _Y = ±4V	+25°C	±1.6	mA
Output Resistance	Z _{OUT}	V _{OUT} = ±10V	+25°C	1.5	MΩ
Output Capacitance	C _{OUT}		+25°C	6.5	pF

NOTE:

- Offset voltage applied to minimize feedthrough signal.

All Intersil semiconductor products are manufactured, assembled and tested under **ISO9000** quality systems certification.

Intersil products are sold by description only. Intersil Corporation reserves the right to make changes in circuit design and/or specifications at any time without notice. Accordingly, the reader is cautioned to verify that data sheets are current before placing orders. Information furnished by Intersil is believed to be accurate and reliable. However, no responsibility is assumed by Intersil or its subsidiaries for its use; nor for any infringements of patents or other rights of third parties which may result from its use. No license is granted by implication or otherwise under any patent or patent rights of Intersil or its subsidiaries.

For information regarding Intersil Corporation and its products, see web site <http://www.intersil.com>