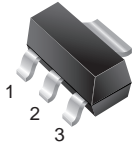
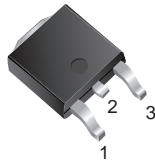

## 1.5A Low Dropout Positive Adjustable Regulator

**SOT-223**

GS1086CST

**TO-252  
(DPak)**

GS1086CE

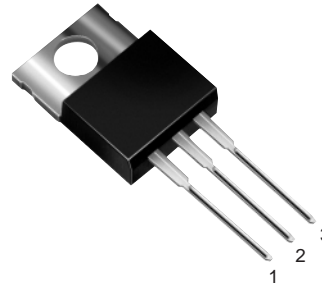
**TO-220AB**

GS1086CT

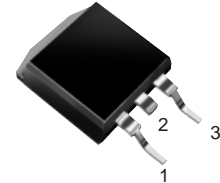
**TO-263AB  
(D<sup>2</sup>Pak)**

GS1086CM

### Pin Definition

1. Adjust/Gnd.
2.  $V_{out}$  (tab)
3.  $V_{in}$

### Features

- Dropout Voltage 1.3V at 1.5A Output Current
- Fast Transient Response
- Line Regulation typically at 0.015%
- Load Regulation typically at 0.1%
- Internal thermal and current limiting
- Adjustable Output Voltage or Fixed 2.5V, 2.85V, 3.3V, 5V
- Standard 3-Pin Power Packages

### Description

The GS1086 is a low dropout three terminal regulator with 1.5A output current capability. The output voltage is adjustable with the use of a resistor divider. For fixed output voltage versions, the output voltage is internally set at 2.5V, 2.85V, 3.3V or 5V. Dropout is guaranteed at a maximum of 1.5V at maximum output current. Its low dropout voltage and fast transient response make it ideal for low voltage microprocessor applications. Internal current and thermal limiting provides protection against any overload condition that would create excessive junction temperatures.

### Applications

- Post Regulator for Switching Supply
- Battery Chargers
- Constant-Current Regulators
- PC Add-On Card

### Functional Block Diagram

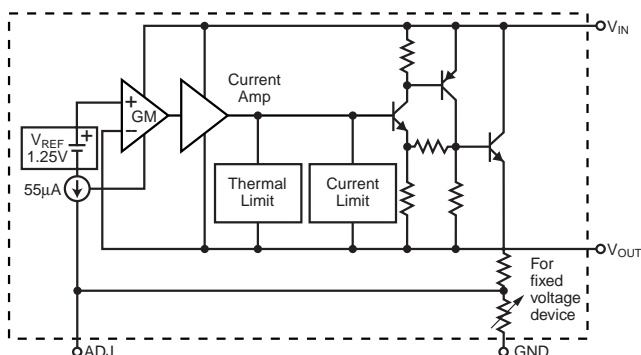

### Mechanical Data

**Case:** TO-220AB, TO-263AB (D<sup>2</sup>PAK), TO-252 (DPAK) and SOT-223

**High temperature soldering guaranteed:**  
 260°C/10 seconds at terminals

*Case outlines are on the back page*



**Maximum Ratings and Thermal Characteristics** ( $T_A = 25^\circ\text{C}$  unless otherwise noted)

Parameter	Symbol	Value	Unit
Vin Pin to ADJ/GND Pin	Vin	7	V
Thermal Resistance – Junction to Case	$R_{\theta JC}$	TO-220AB	3.0
		TO-252	8.0
		TO-263AB	3.0
		SOT-223	15.0
Operating Junction Temperature Range	$T_J$	0 to +125	$^\circ\text{C}$
Storage Temperature Range	$T_{stg}$	-65 to 150	$^\circ\text{C}$

**Electrical Characteristics**<sup>(1)</sup>  $T_J = 25^\circ\text{C}$ <sup>(2)</sup>,  $V_{IN} = 5\text{V}$ ,  $I_o = 10\text{mA}$  unless otherwise noted.

Parameter	Symbol	Test Conditions	Min	Typ	Max	Unit
Reference Voltage	$V_{REF}$	$T_J = 25^\circ\text{C}$ $0^\circ\text{C} \leq T_J \leq 125^\circ\text{C}$ $2.65\text{V} \leq V_{IN} \leq 7\text{V}$ $10\text{mA} \leq I_o \leq 1.5\text{A}$	1.238 1.225	1.250 1.250	1.262 1.275	V
Output Voltage	$V_{OUT}$	GS1086-2.5 $V_{IN} = 5\text{V}$ GS1086-2.85 $V_{IN} = 5\text{V}$ GS1086-3.3 $V_{IN} = 5\text{V}$ GS1086-5 $V_{IN} = 7\text{V}$ GS1086 $0^\circ\text{C} \leq T_J \leq 125^\circ\text{C}$ $2.65\text{V} \leq V_{IN} \leq 7\text{V}$ $10\text{mA} \leq I_o \leq 1.5\text{A}$	2.47 2.82 3.26 4.95 0.98 $V_N$	2.5 2.85 3.30 5.00 $V_N$	2.53 2.88 3.33 5.05 1.02 $V_N$	V
Line Regulation	$REG_{line}$	$2.65\text{V} \leq V_{IN} \leq 7\text{V}$ $T_J = 25^\circ\text{C}$ $0^\circ\text{C} \leq T_J \leq 125^\circ\text{C}$		0.015 0.02	0.2 0.2	% $V_O$
Load Regulation	$REG_{load}$	$10\text{mA} \leq I_o \leq 1.5\text{A}$ $T_J = 25^\circ\text{C}$ $0^\circ\text{C} \leq T_J \leq 125^\circ\text{C}$		0.1 0.2	0.3 0.4	% $V_O$
Dropout Voltage	$V_{DROP}$	$0^\circ\text{C} \leq T_J \leq 125^\circ\text{C}$ $I_o = 1.5\text{A}$ $I_o = 1.0\text{A}$ $I_o = 500\text{mA}$		1.3 1.25 1.2	1.5 1.45 1.4	V
Output Current	$I_o$	$0^\circ\text{C} \leq T_J \leq 125^\circ\text{C}$	1.5	2.0		A
Adjust Pin Current	$I_{adj}$	$2.65 \leq V_{in} \leq 7\text{V}$ $10\text{mA} \leq I_o \leq 1.5\text{A}$ $0^\circ\text{C} \leq T_J \leq 125^\circ\text{C}$		55	120	$\mu\text{A}$
Adjust Pin Current Change	$\Delta I_{adj}$	$2.65 \leq V_{in} \leq 7\text{V}$ $10\text{mA} \leq I_o \leq 1.5\text{A}$ $0^\circ\text{C} \leq T_J \leq 125^\circ\text{C}$		0.2	5	$\mu\text{A}$
Temperature Stability	$T_S$	$I_o = 0.5\text{A}$ $0^\circ\text{C} \leq T_J \leq 125^\circ\text{C}$		0.8		% $V_O$
Minimum Load Current Adjustable Version	$I_{LMIN}$	$0^\circ\text{C} \leq T_J \leq 125^\circ\text{C}$		3	10	mA

**Electrical Characteristics<sup>(1)</sup> (con't.)**  $T_J = 25^\circ\text{C}$ <sup>(2)</sup>,  $V_{IN} = 5\text{V}$ ,  $I_o = 10\text{mA}$  unless otherwise noted.

Parameter	Symbol	Test Conditions	Min	Typ	Max	Unit
Quiescent Current Fixed Voltage Version	$I_Q$	$0^\circ\text{C} \leq T_J \leq 125^\circ\text{C}$		10	14	mA
RMS Output Noise	N	$10\text{Hz} \leq f \leq 10\text{kHz}$		0.003		% $V_O$
Ripple Rejection Ratio	RR	$f = 120\text{Hz}$ , $C_O = 25\mu\text{F}$ $C_{adj} = 25\mu\text{F}$	60	68		dB
Thermal Regulation	$R_{TH}$	$T_A = 25^\circ\text{C}$ , 30ms Pulse		0.02	0.05	%/W
Long Term Stability		$T_A = 125^\circ\text{C}$ , 1000 Hrs		0.3		% $V_O$

**Notes:**

(1) All parameters, except nominal output voltage are specified for the variable voltage version, allowing a wider  $V_{IN}$  Range.

The specified limits also apply for the fixed voltage versions over the allowable input voltage range: GS1086-2.5 (3.9V - 7.0V), GS1086-2.85 (4.25V - 7.0V), GS1086-3.3 (4.75V - 7.0V), GS1086-5 (6.4V - 7.0V).

(2) To maintain the specified junction temperatures, low duty cycle pulse testing is required for most parameters.

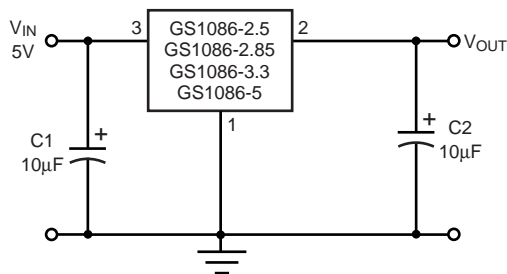
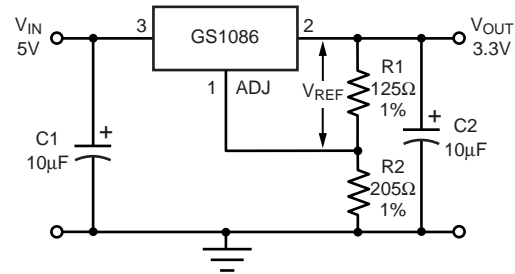
**Typical Application Circuit**

**Fixed Voltage Regulator**

**Adjustable Voltage Regulator**
**Notes:**

$$V_{REF} = V_{OUT} - V_{ADJ} = 1.25\text{V (typ.)}$$

$$V_{OUT} = V_{REF} \times (1 + R_2/R_1) + I_{ADJ} \times R_2$$

$$I_{ADJ} = 55\mu\text{A (typ.)}$$

(1) C1 needed if device is far away from filter capacitors

(2) C2 required for stability

**Ratings and Characteristic Curves** ( $T_A = 25^\circ\text{C}$  unless otherwise noted)

**Fig. 1 – Dropout Voltage ( $V_{OUT} = 3.3\text{V}$ )**

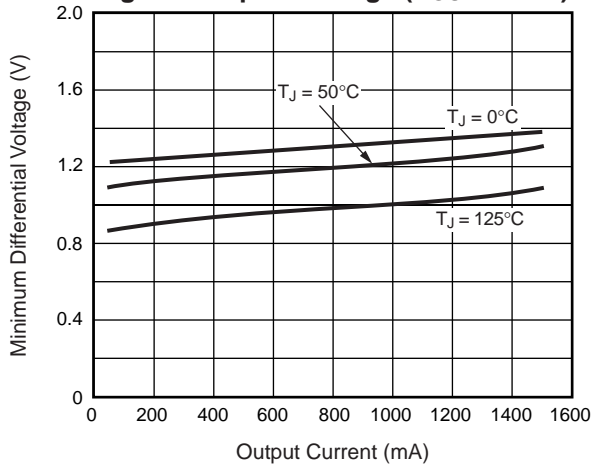

**Fig. 2 – Dropout Voltage v.s. Temperature**

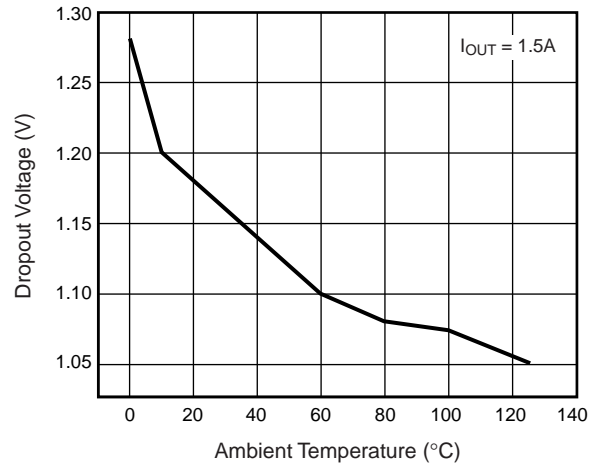

**Fig. 3 – Minimum Load Current (Adjustable Version)**

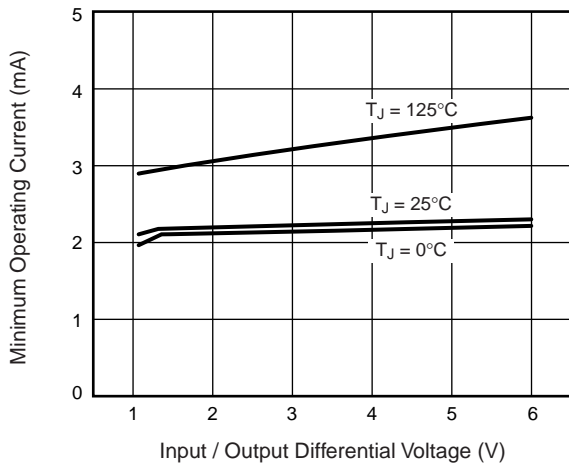

**Fig. 4 – Adjust Pin Current**

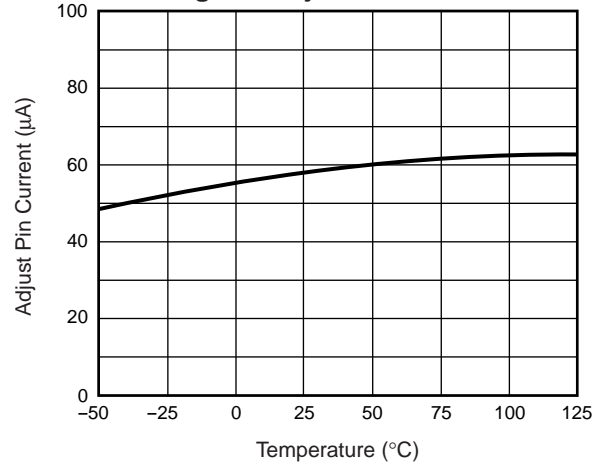

**Fig. 5 – Temperature Stability**

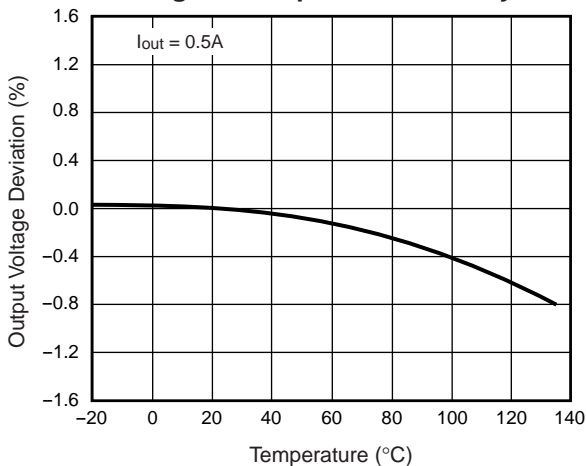

**Fig. 6 – Ripple Rejection (with  $C_{adj} 25\mu\text{F}$ )**

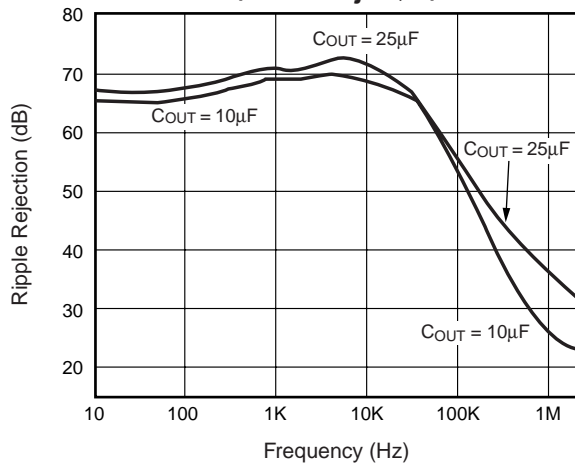

**Ratings and Characteristic Curves** ( $T_A = 25^\circ\text{C}$  unless otherwise noted)

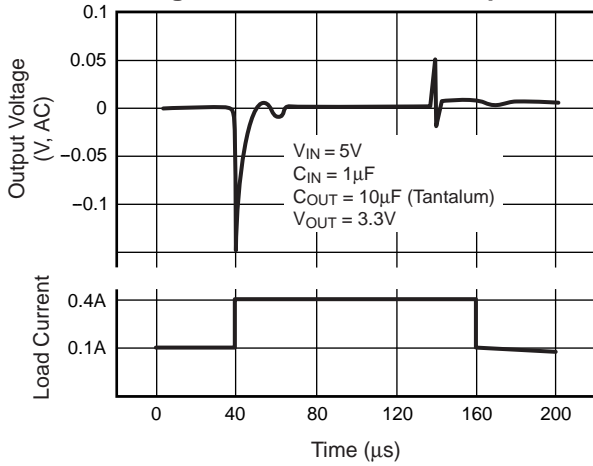
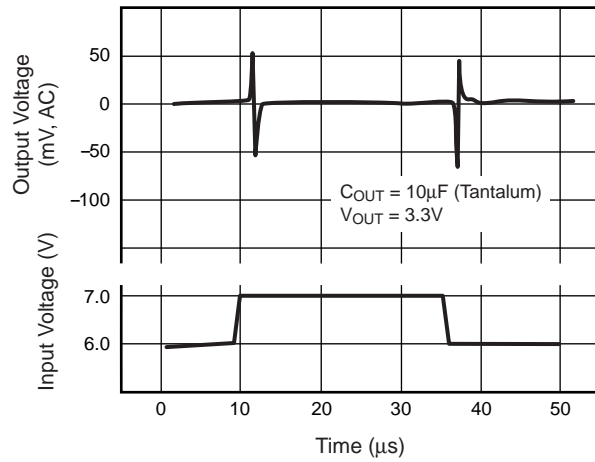
**Fig. 7 – Load Transient Response**

**Fig. 8 – Line Transient Response**

**Ordering Information**
**GS1086Cxx xxx**

 Output Voltage  
 Default: Adj.  
 2.5: 2.5V  
 2.85: 2.85V  
 3.3: 3.3V  
 5: 5.0V

 Package Type  
 ST: SOT-223  
 T: TO-220  
 M: TO-263  
 E: TO-252

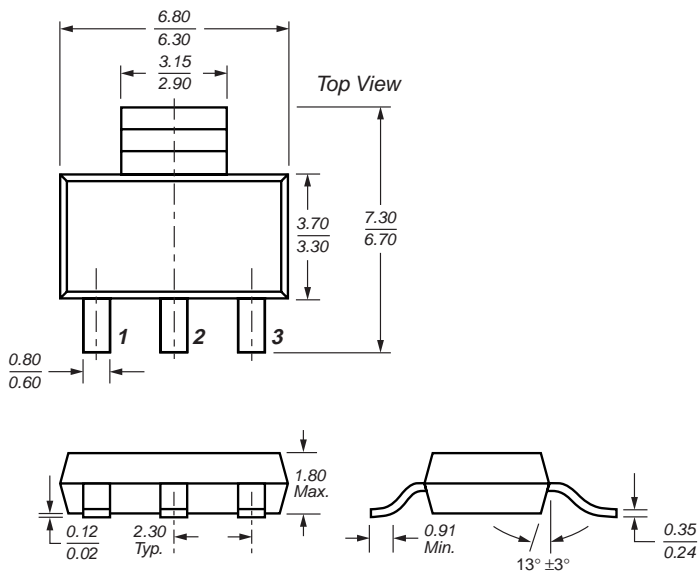
**Case Outlines**

**SOT-223**



**TO-252 (DPAK)**

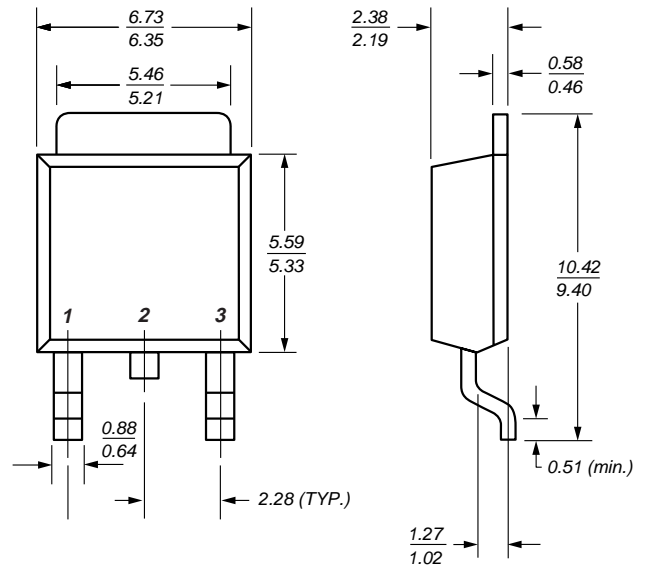

Dimensions in millimeters

**TO-263**

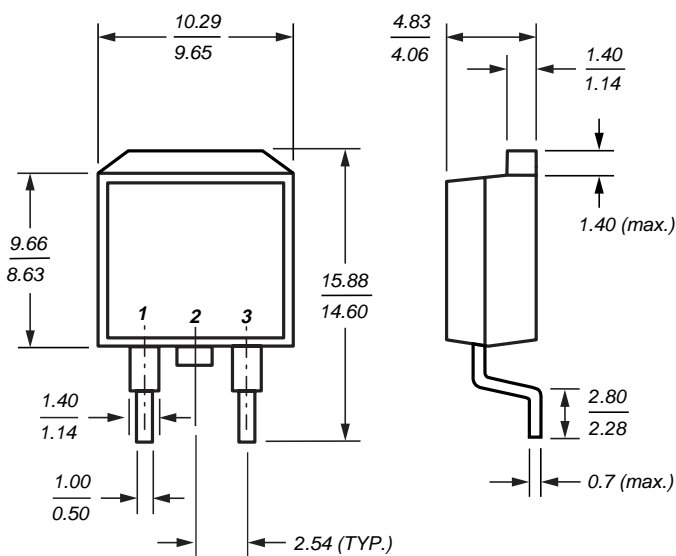

**TO-220**

