

XC6406 Series

High Current Dual Positive Regulator



Low Power Consumption : 40 μ A (MAX.)
Dropout Voltage : 150mV @ 100mA
: 300mV @ 200mA
Maximum Output Current : More Than 400mA
High Accuracy : \pm 2%

APPLICATIONS

CD-ROM, DVD
Battery powered equipment
PDAs
Cameras, Video recorders
Portable AV equipment
Reference voltage

GENERAL DESCRIPTION

The XC6406 series are highly precise, low power consumption, dual positive regulators. They are fabricated using Torex's CMOS process. Performance features of the series include high current and low dropout voltage, and the series features a voltage reference, and error amplifier, a current limiter and a phase compensation circuit plus a driver transistor.

Output voltage of each regulator 1 and regulator 2 is selectable in 100mV steps within the range of 1.8V to 6.0V.

The XC6406 series is available in the SOP-8 package.

FEATURES

Maximum Output Current : 400mA (within the power dissipation)
Maximum Operating Voltage : 8.0V
Output Setting Voltage Range : 1.8 ~ 6.0V (100mV steps)
Accuracy : \pm 2%
Low Power Consumption : 20 μ A (TYP.)
Line Regulation : 0.2% / V (TYP.)
Output Voltage Temperature Range : 100 ppm/ (TYP.)
Operating Temperature Range : - 40 ~ 85
Small Packages : SOP-8
: SOP-8FD
(Under development)

TYPICAL APPLICATION CIRCUIT

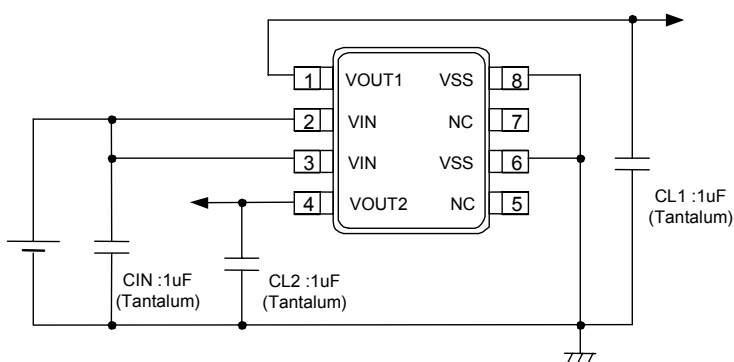

* Please connect the VIN pins No. 2 and No. 3 externally.

**Please connect the Vss pins No. 6 and No. 8 externally.

PIN CONFIGURATION

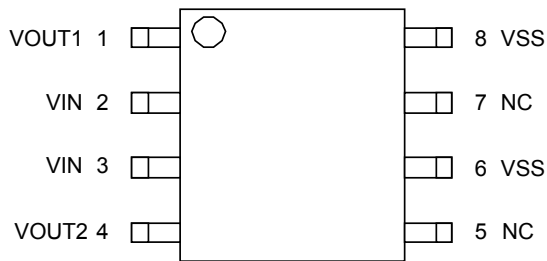

SOP-8 & SOP-8FD (TOP VIEW)

* Please connect the VIN pins No. 2 and No. 3 externally.

**Please connect the Vss pins No. 6 and No. 8 externally.

PIN ASSIGNMENT

PIN NUMBER	PIN NAME	FUNCTION
1	VOUT1	Regulator 1 - Output
2	VIN	Power Input
3	VIN	Power Input
4	VOUT2	Regulator 2 - Output
5	NC	No Connection
6	VSS	Ground
7	NC	No Connection
8	VSS	Ground

PRODUCT CLASSIFICATION

Ordering Information

XC6406

DESIGNATOR	DESCRIPTION	SYMBOL	DESCRIPTION
	Type of Regulator 1 (VR1)	P	: Short-circuit protection circuit built-in
		E	: No current limiter circuit built-in
	Type of Regulator 2 (VR2)	P	: Short-circuit protection circuit built-in
		E	: No current limiter circuit built-in
	Output Voltage of VR1 & VR2	18~ 60	: VR1 setting output voltage range: 1.8V ~ 6.0V VR2 setting output voltage range: 1.8V ~ 6.0V 100mV increments are available.(*1)
	Package	S	: SOP-8
		(T.B.D.*2)	: SOP-8FD
	Device Orientation	R	: Embossed tape, Standard feed
		L	: Embossed tape, Reverse feed

*1: Output voltage of 50mV steps is applied only for 2.85V type.

*2: T.B.D.: To be determined

PACKAGING INFORMATION

SOP-8

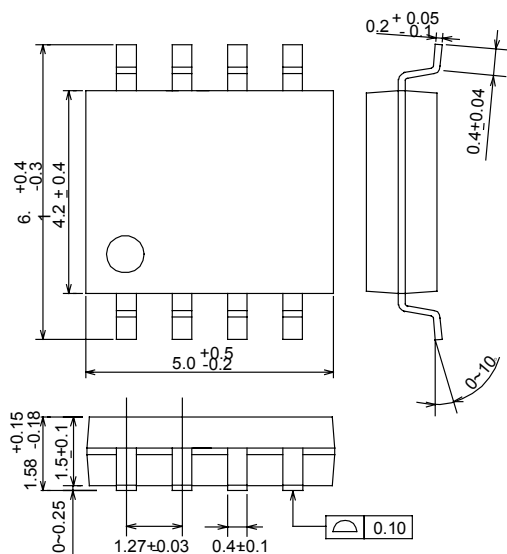

SOP-8FD

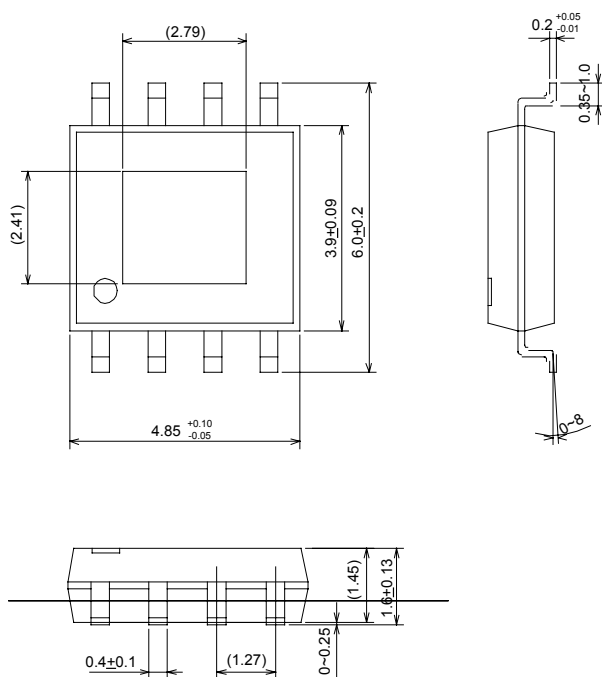

MARKING RULE

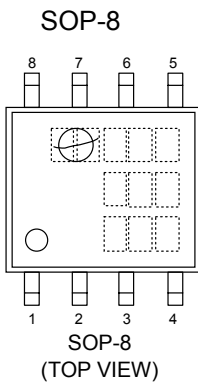

Represents product series

MARK		PRODUCT SERIES
①	②	
0	6	XC6406****S*

Represents type of VR1 regulator

MARK	VR1REGULATOR TYPE	PRODUCT SERIES
P	Short-Circuit Protection Circuit Built-In	XC6406P***S*
E	No Current Limiter Circuit Built-In	XC6406E***S*

Represents type of VR2 regulator

MARK	VR2REGULATOR TYPE	PRODUCT SERIES
P	Short-Circuit Protection Circuit Built-In	XC6406P***S*
E	No Current Limiter Circuit Built-In	XC6406E***S*

Represents VR output voltage

ex)

MARK		VOLTAGE(V)		PRODUCT SERIES
		VR1	VR2	
0	1	3.3	2.5	XC6406**01S*

Represents a least significant digit of production year

ex)

MARK	PRODUCTION YEAR
3	2003
4	2004

Represents production lot number

0 to 9, A to Z repeated(G,I,J,O,Q,W excepted)

Note: No character inversion used.

ex)

MARK		PRODUCTION LOT NUMBER
⑧	⑨	
-	3	03
0	1	1A

ABSOLUTE MAXIMUM RATINGS

Ta = 25

PARAMETER	SYMBOL	RATINGS	UNITS
Input Voltage	V _{IN}	10	V
Output Current	I _{OUT1} + I _{OUT2}	600	mA
Output Voltage	V _{OUT1} / 2	V _{SS} - 0.3 ~ V _{IN} + 0.3	V
EN Pin Voltage	V _{EN1} / 2	V _{SS} - 0.3 ~ V _{IN} + 0.3	V
Power Dissipation	SOP-8	Pd	mW
	SOP-8FD		
Operating Temperature Range	T _{opr}	- 40 ~ + 85	
Storage Temperature Range	T _{stg}	- 55 ~ + 125	

ELECTRICAL CHARACTERISTICS

XC6406EExx

PARAMETER	SYMBOL	CONDITIONS	MIN.	TYP.	MAX.	UNITS
Supply Current	I _{DD}	V _{IN} = 7V	-	20	40	μA
Input Voltage	V _{IN}		-	-	8.0	V

 * Please connect the V_{IN} pins No. 2 and No. 3 externally.

 **Please connect the V_{SS} pins No. 6 and No. 8 externally

 V_{OUT}(T) = 1.8V

Ta=25

PARAMETER	SYMBOL	CONDITIONS	MIN.	TYP.	MAX.	UNITS
Output Voltage (*2)	V _{OUT} (E)	V _{IN} =2.8V, I _{OUT} =40mA	1.764	1.800 V _{OUT} (T)	1.836	V
Maximum Output Current	I _{OUT} MAX	V _{IN} =2.8V, V _{OUT} = V _{OUT} (E) x 0.9	400	-	-	mA
Load Regulation	ΔV _{OUT}	V _{IN} =2.8V, I _{OUT} 1mA ~ 200mA	-	40	100	mV
Dropout Voltage (*3)	V _{dif1}	I _{OUT} =100mA	-	200	300	mV
	V _{dif2}	I _{OUT} =200mA	-	400	600	mV
Line Regulation	$\frac{\Delta V_{OUT}}{\Delta V_{IN} \cdot V_{OUT}}$	2.8V V _{IN} 8.0V, I _{OUT} =40mA	-	0.2	0.3	% / V
Output Voltage Temperature Range	$\frac{\Delta V_{OUT}}{\Delta T_{opr} \cdot V_{OUT}}$	I _{OUT} =40mA, -40 ~ T _{opr} 85	-	± 100	-	ppm / °C

NOTE:

 *1: V_{OUT}(T) : Specified output voltage

 *2: V_{OUT}(E) : Effective output voltage

 (I.e. the output voltage when "V_{OUT}(T)+1.0V" is provided at the V_{IN} pin while maintaining a certain I_{OUT}.)

 *3: V_{dif}={V_{IN}⁽⁵⁾ - V_{OUT}⁽⁴⁾}

 *4: V_{OUT}1: A voltage equal to 98% of the output voltage whenever an amply stabilized V_{OUT}1=I_{OUT}{V_{OUT}(T)+1.0V} is input.

 *5: V_{IN}1=The input voltage when V_{OUT}1 appears as input voltage is gradually decreased.

ELECTRICAL CHARACTERISTICS (Continued)

XC6406EExx (Continued)

V_{OUT(T)} = 2.5V

T_a=25

PARAMETER	SYMBOL	CONDITIONS	MIN.	TYP.	MAX.	UNITS
Output Voltage (*2)	V _{OUT(E)}	V _{IN} =3.5V, I _{OUT} =40mA	2.450	2.500 V _{OUT(T)}	2.550	V
Maximum Output Current	I _{OUTMAX}	V _{IN} =3.5V, V _{OUT} V _{OUT(E)} x 0.93	400	-	-	mA
Load Regulation	ΔV _{OUT}	V _{IN} =3.5V, 1mA I _{OUT} 200mA	-	40	100	mV
Dropout Voltage (*3)	V _{dif1}	I _{OUT} =100mA	-	170	250	mV
	V _{dif2}	I _{OUT} =200mA	-	320	500	mV
Line Regulation	$\frac{\Delta V_{OUT}}{\Delta V_{IN} \cdot V_{OUT}}$	3.5V V _{IN} 8.0V, I _{OUT} =40mA	-	0.2	0.3	% / V
Output Voltage Temperature Range	$\frac{\Delta V_{OUT}}{\Delta T_{opr} \cdot V_{OUT}}$	I _{OUT} =40mA, -40 T _{opr} 85	-	± 100	-	ppm /

NOTE:

*1: V_{OUT(T)} : Specified output voltage

*2: V_{OUT(E)} : Effective output voltage

(I.e. the output voltage when "V_{OUT(T)}+1.0V" is provided at the V_{IN} pin while maintaining a certain I_{OUT}.)

*3: V_{dif}={V_{IN1}⁽⁵⁾ - V_{OUT1}⁽⁴⁾}

*4: V_{OUT1}: A voltage equal to 98% of the output voltage whenever an amply stabilized V_{OUT1}=I_{OUT}{V_{OUT(T)}+1.0V} is input.

*5: V_{IN1}=The input voltage when V_{OUT1} appears as input voltage is gradually decreased.

V_{OUT(T)} = 3.3V

T_a=25

PARAMETER	SYMBOL	CONDITIONS	MIN.	TYP.	MAX.	UNITS
Output Voltage (*2)	V _{OUT(E)}	V _{IN} =4.3V, I _{OUT} =40mA	3.234	3.300 V _{OUT(T)}	3.366	V
Maximum Output Current	I _{OUTMAX}	V _{IN} =4.3V, V _{OUT} V _{OUT(E)} x 0.93	400	-	-	mA
Load Regulation	ΔV _{OUT}	V _{IN} =4.3V, 1mA I _{OUT} 200mA	-	40	100	mV
Dropout Voltage (*3)	V _{dif1}	I _{OUT} =100mA	-	150	220	mV
	V _{dif2}	I _{OUT} =200mA	-	300	420	mV
Line Regulation	$\frac{\Delta V_{OUT}}{\Delta V_{IN} \cdot V_{OUT}}$	3.5V V _{IN} 8.0V, I _{OUT} =40mA	-	0.2	0.3	% / V
Output Voltage Temperature Range	$\frac{\Delta V_{OUT}}{\Delta T_{opr} \cdot V_{OUT}}$	I _{OUT} =40mA, -40 T _{opr} 85	-	± 100	-	ppm /

NOTE:

*1: V_{OUT(T)} : Specified output voltage

*2: V_{OUT(E)} : Effective output voltage

(I.e. the output voltage when "V_{OUT(T)}+1.0V" is provided at the V_{IN} pin while maintaining a certain I_{OUT}.)

*3: V_{dif}={V_{IN1}⁽⁵⁾ - V_{OUT1}⁽⁴⁾}

*4: V_{OUT1}: A voltage equal to 98% of the output voltage whenever an amply stabilized V_{OUT1}=I_{OUT}{V_{OUT(T)}+1.0V} is input.

*5: V_{IN1}=The input voltage when V_{OUT1} appears as input voltage is gradually decreased.