

MITSUBISHI MICROCOMPUTERS 3822 Group

SINGLE-CHIP 8-BIT CMOS MICROCOMPUTER

DESCRIPTION

The 3822 group is the 8-bit microcomputer based on the 740 family core technology.

The 3822 group has the LCD drive control circuit, an 8-channel A-D converter, and a serial I/O as additional functions.

The various microcomputers in the 3822 group include variations of internal memory size and packaging. For details, refer to the section on part numbering.

For details on availability of microcomputers in the 3822 group, refer to the section on group expansion.

FEATURES

- Basic machine-language instructions 71
- The minimum instruction execution time 0.5 μ s
(at 8 MHz oscillation frequency)
- Memory size
 - ROM 4 K to 48 K bytes
 - RAM 192 to 1024 bytes
- Programmable input/output ports 49
- Software pull-up/pull-down resistors (Ports P0-P7 except port P40)
- Interrupts 17 sources, 16 vectors
(includes key input interrupt)
- Timers 8-bit X 3, 16-bit X 2
- Serial I/O 8-bit X 1 (UART or Clock-synchronized)
- A-D converter 8-bit X 8 channels
- LCD drive control circuit
 - Bias 1/2, 1/3
 - Duty 1/2, 1/3, 1/4
 - Common output 4
 - Segment output 32

- 2 clock generating circuits
(connect to external ceramic resonator or quartz-crystal oscillator)
- Power source voltage
 - In high-speed mode 4.0 to 5.5 V
 - In middle-speed mode 2.5 to 5.5 V
(Extended operating temperature version:
2.0 to 5.5 V, Ta = -20 to 85°C
3.0 to 5.5 V, Ta = -40 to -20°C)
(One time PROM version: 2.5 to 5.5 V)
(M version: 2.2 to 5.5 V)
(H version: 2.0 to 5.5 V)
 - In low-speed mode 2.5 to 5.5 V
(Extended operating temperature version:
2.0 to 5.5 V, Ta = -20 to 85°C
3.0 to 5.5 V, Ta = -40 to -20°C)
(One time PROM version: 2.5 to 5.5 V)
(M version: 2.2 to 5.5 V)
(H version: 2.0 to 5.5 V)
- Power dissipation
 - In high-speed mode 32 mW
(at 8 MHz oscillation frequency, at 5 V power source voltage)
 - In low-speed mode 45 μ W
(at 32 kHz oscillation frequency, at 3 V power source voltage)
- Operating temperature range -20 to 85°C
(Extended operating temperature version: -40 to 85°C)

APPLICATIONS

Camera, household appliances, consumer electronics, etc.

PIN CONFIGURATION (TOP VIEW)

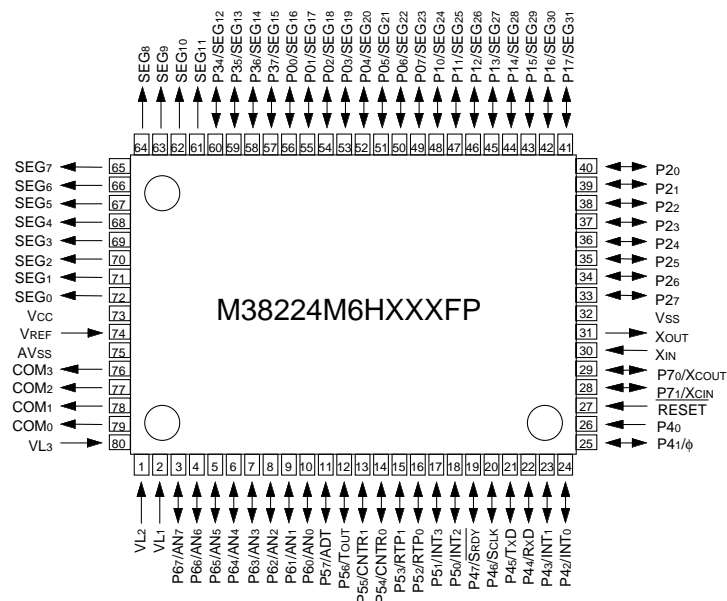

Package type : 80P6N-A (80-pin plastic-molded QFP)

Fig. 1 M38224M6HXXXFP pin configuration
(The pin configuration of 80D0 is same as this.)

PIN CONFIGURATION (TOP VIEW)

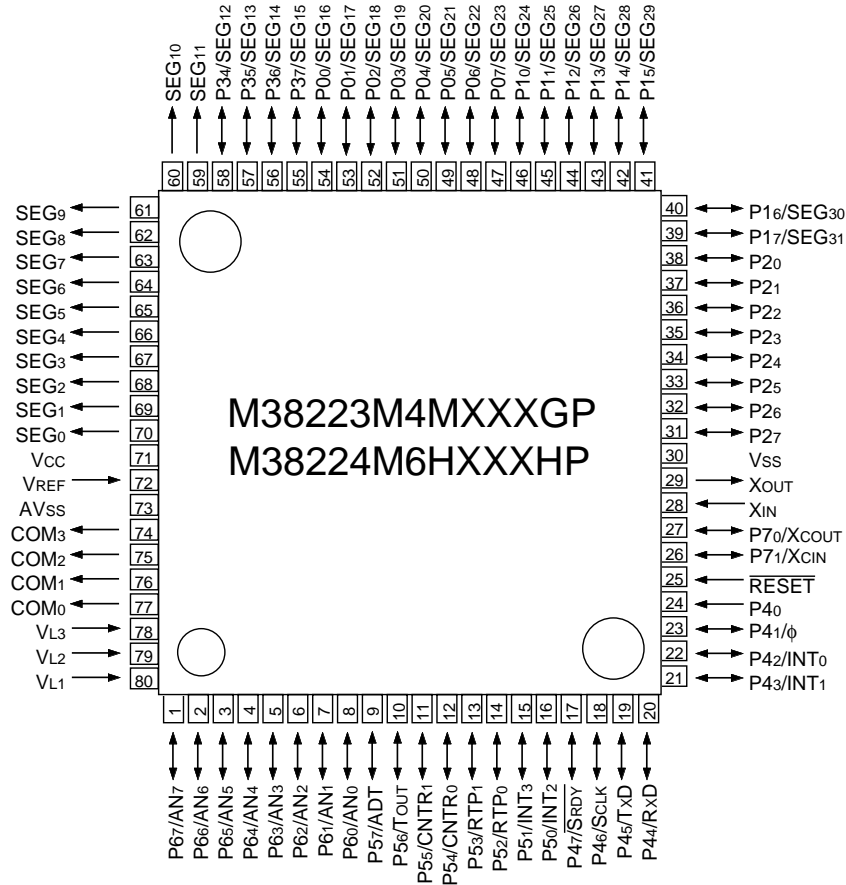

**Package type : 80P6S-A/80P6Q-A
(80-pin plastic-molded QFP)**

Fig. 2 M38223M4MXXXGP/M38224M6HXXXHP pin configuration

FUNCTIONAL BLOCK DIAGRAM (Package type : 80P6Q-A)

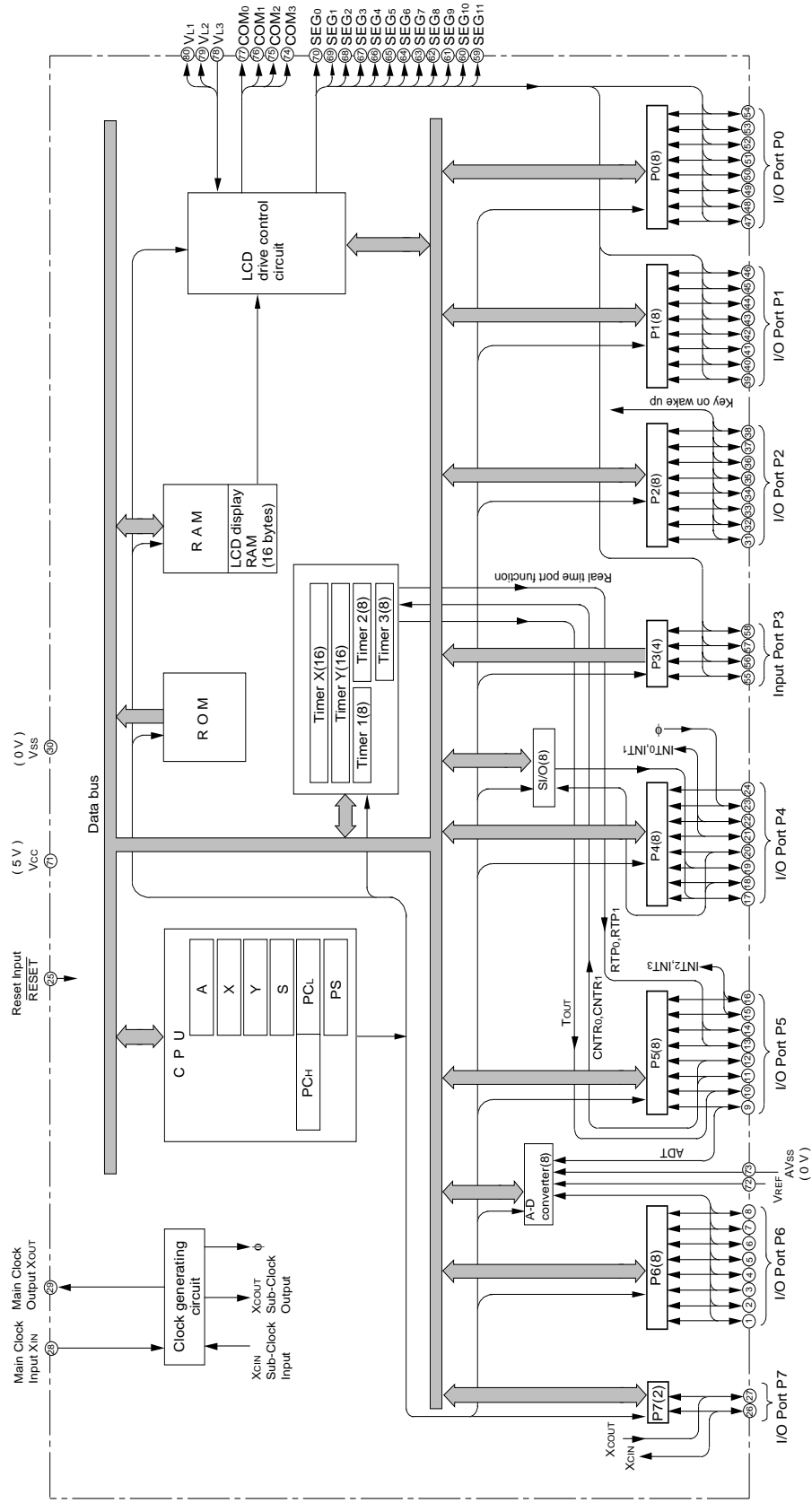

Fig. 3 Functional block diagram

PIN DESCRIPTION

Table 1 Pin description (1)

Pin	Name	Function	
			Function except a port function
VCC, VSS	Power source	<ul style="list-style-type: none"> Apply voltage of power source to VCC, and 0 V to VSS. (For the limits of VCC, refer to "Recommended operating conditions"). 	
VREF	Analog reference voltage	<ul style="list-style-type: none"> Reference voltage input pin for A-D converter. 	
AVSS	Analog power source	<ul style="list-style-type: none"> GND input pin for A-D converter. Connect to VSS. 	
RESET	Reset input	<ul style="list-style-type: none"> Reset input pin for active "L". 	
XIN	Clock input	<ul style="list-style-type: none"> Input and output pins for the main clock generating circuit. Feedback resistor is built in between XIN pin and XOUT pin. 	
XOUT	Clock output	<ul style="list-style-type: none"> Connect a ceramic resonator or a quartz-crystal oscillator between the XIN and XOUT pins to set the oscillation frequency. If an external clock is used, connect the clock source to the XIN pin and leave the XOUT pin open. This clock is used as the oscillating source of system clock. 	
VL1-VL3	LCD power source	<ul style="list-style-type: none"> Input $0 \leq VL1 \leq VL2 \leq VL3 \leq VCC$ voltage. Input 0 - VL3 voltage to LCD. 	
COM0-COM3	Common output	<ul style="list-style-type: none"> LCD common output pins. COM2 and COM3 are not used at 1/2 duty ratio. COM3 is not used at 1/3 duty ratio. 	
SEG0-SEG11	Segment output	<ul style="list-style-type: none"> LCD segment output pins. 	
P00/SEG16-P07/SEG23	I/O port P0	<ul style="list-style-type: none"> 8-bit output port. CMOS compatible input level. CMOS 3-state output structure. 	<ul style="list-style-type: none"> LCD segment output pins
P10/SEG24-P17/SEG31	I/O port P1	<ul style="list-style-type: none"> I/O direction register allows each port to be individually programmed as either input or output. Pull-down control is enabled. 	
P20 - P27	I/O port P2	<ul style="list-style-type: none"> 8-bit I/O port. CMOS compatible input level. CMOS 3-state output structure. I/O direction register allows each pin to be individually programmed as either input or output. Pull-up control is enabled. 	<ul style="list-style-type: none"> Key input (key-on wake-up) interrupt input pins
P34/SEG12 - P37/SEG15	Input port P3	<ul style="list-style-type: none"> 4-bit input port. CMOS compatible input level. Pull-down control is enabled. 	<ul style="list-style-type: none"> LCD segment output pins

Table 2 Pin description (2)

Pin	Name	Function	Function except a port function
P40	Input port P4	<ul style="list-style-type: none"> •1-bit Input port. •CMOS compatible input level. 	
P41/φ	I/O port P4	<ul style="list-style-type: none"> •7-bit I/O port. •CMOS compatible input level. •CMOS 3-state output structure. •I/O direction register allows each pin to be individually programmed as either input or output. •Pull-up control is enabled. 	•φ clock output pin
P42/INT0, P43/INT1			•Interrupt input pins
P44/RxD, P45/TxD, P46/SCLK, P47/SRDY			•Serial I/O function pins
P50/INT2, P51/INT3			•Interrupt input pins
P52/RTP0, P53/RTP1	I/O port P5	<ul style="list-style-type: none"> •8-bit I/O port. •CMOS compatible input level. •CMOS 3-state output structure. •I/O direction register allows each pin to be individually programmed as either input or output. •Pull-up control is enabled. 	•Real time port function pins
P54/CNTR0, P55/CNTR1			•Timer X, Y function pins
P56/TOUT			•Timer 2 output pins
P57/ADT			•A-D trigger input pins
P60/AN0– P67/AN7	I/O port P6	<ul style="list-style-type: none"> •8-bit I/O port. •CMOS compatible input level. •CMOS 3-state output structure. •I/O direction register allows each pin to be individually programmed as either input or output. •Pull-up control is enabled. 	•A-D conversion input pins
P70/XCOUT, P71/XCIN	I/O port P7	<ul style="list-style-type: none"> •2-bit I/O port. •CMOS compatible input level. •CMOS 3-state output structure. •I/O direction register allows each pin to be individually programmed as either input or output. •Pull-up control is enabled. 	<ul style="list-style-type: none"> •Sub-clock generating circuit I/O pins. (Connect a resonator. External clock cannot be used.)

PART NUMBERING

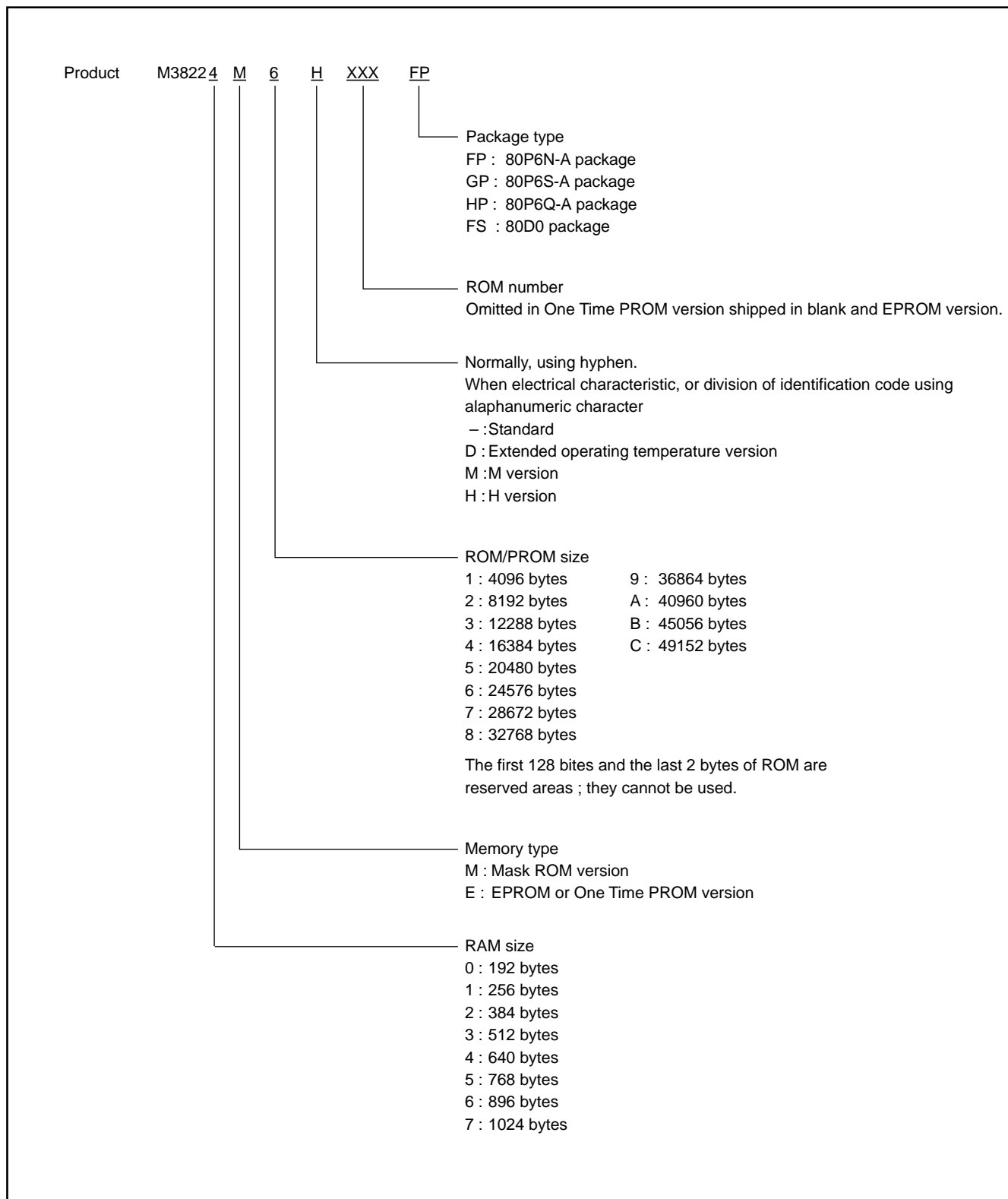

Fig. 4 Part numbering

GROUP EXPANSION (STANDARD, ONE TIME PROM VERSION, EPROM VERSION)

Mitsubishi plans to expand the 3822 group (Standard, One Time PROM version, EPROM version) as follows:

Memory Type

Support for Mask ROM, One Time PROM, and EPROM versions

Memory Size

ROM size 8 K to 48 K bytes
RAM size 384 to 1024 bytes

Package

80P6N-A 0.8 mm-pitch plastic molded QFP
80P6S-A 0.65 mm-pitch plastic molded QFP
80P6Q-A 0.5 mm-pitch plastic molded QFP
80D0 0.8 mm-pitch ceramic LCC (EPROM version)

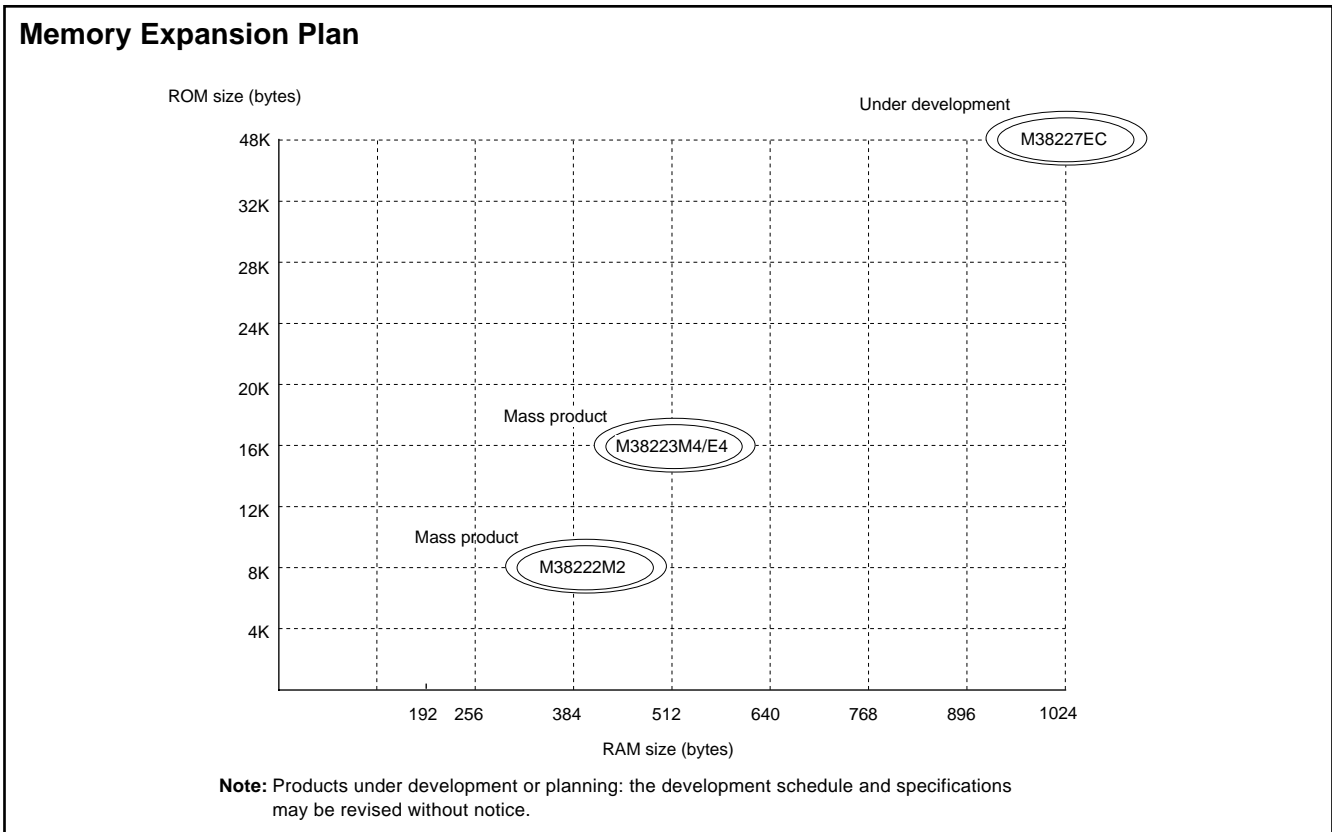

Fig. 5 Memory expansion plan

Currently products are listed below.

Table 3 List of products

As of August 2000

Product	ROM size (bytes) ROM size for User in ()	RAM size (bytes)	Package	Remarks
M38222M2-XXXFP	8192 (8062)	384	80P6N-A	Mask ROM version
M38222M2-XXXGP			80P6S-A	Mask ROM version
M38222M2-XXXHP			80P6Q-A	Mask ROM version
M38223M4-XXXFP	16384 (16254)	512	80P6N-A	Mask ROM version
M38223E4FP				One Time PROM version (blank)
M38223M4-XXXGP			80P6S-A	Mask ROM version
M38223E4GP				One Time PROM version (blank)
M38223M4-XXXHP			80P6Q-A	Mask ROM version
M38223E4HP				One Time PROM version (blank)
M38223E4FS			80D0	EPROM version
M38227ECFP	49152 (49022)	1024	80P6N-A	One Time PROM version (blank)
M38227ECHP			80P6Q-A	One Time PROM version (blank)
M38227ECFS			80D0	EPROM version

**GROUP EXPANSION
(EXTENDED OPERATING TEMPERATURE
VERSION)**

Mitsubishi plans to expand the 3822 group (extended operating temperature version) as follows:

Memory Type

Support for Mask ROM version.

Memory Size

ROM size 48 K bytes

RAM size 1024 bytes

Package

80P6N-A 0.8 mm-pitch plastic molded QFP

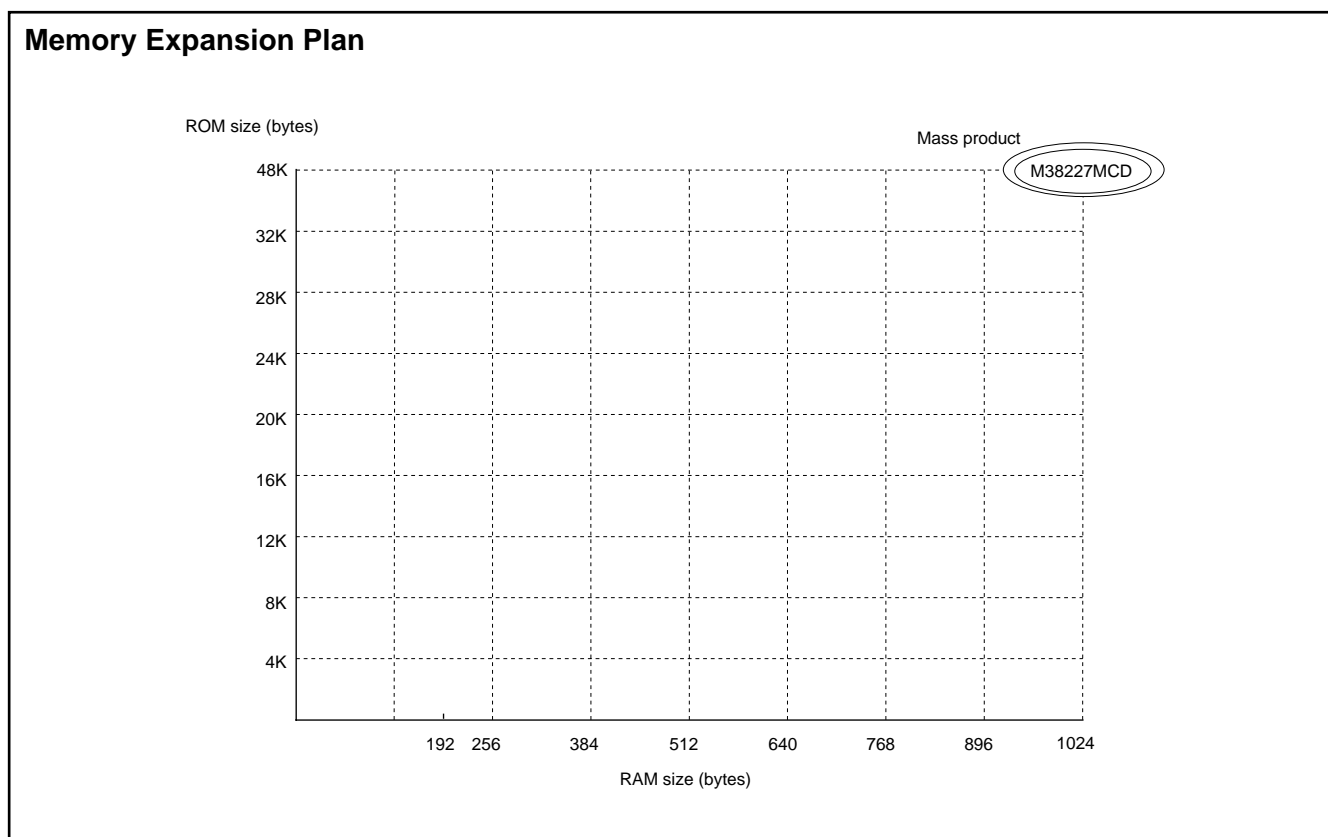

Fig. 6 Memory expansion plan for extended operating temperature version

Currently products are listed below.

Table 4 List of products for extended operating temperature version

As of August 2000

Product	ROM size (bytes) ROM size for User in ()	RAM size (bytes)	Package	Remarks
M38227MCDXXXFP	49152(49022)	1024	80P6N-A	Mask ROM version

GROUP EXPANSION (M VERSION)

Mitsubishi plans to expand the 3822 group (M version) as follows:

Memory Type

Support for Mask ROM version.

Memory Size

ROM size 16 K to 24 K bytes
 RAM size 512 to 640 bytes

Package

80P6N-A 0.8 mm-pitch plastic molded QFP
 80P6S-A 0.65 mm-pitch plastic molded QFP
 80P6Q-A 0.5 mm-pitch plastic molded QFP

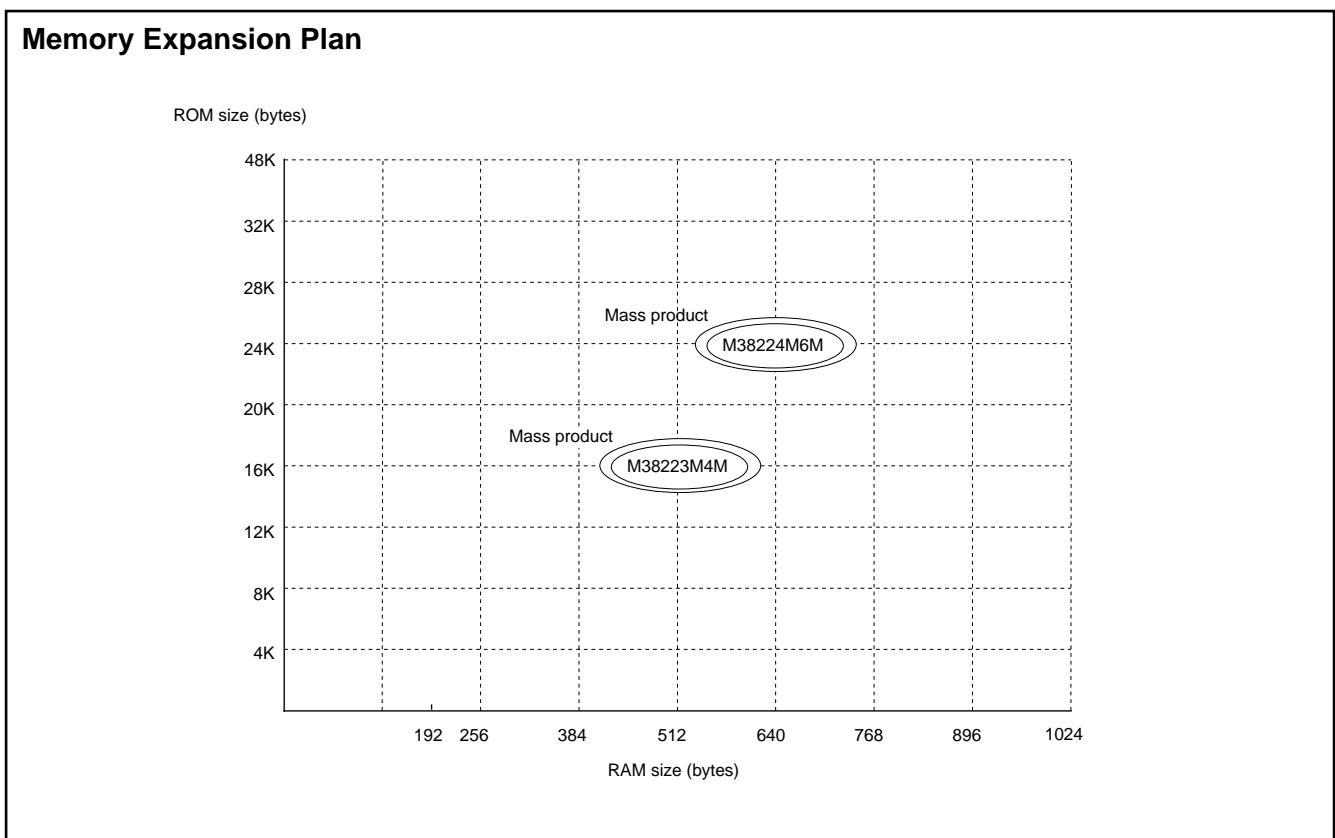

Fig. 7 Memory expansion plan for M version

Currently products are listed below.

Table 5 List of products for M version

As of August 2000

Product	ROM size (bytes) ROM size for User in ()	RAM size (bytes)	Package	Remarks
M38223M4MXXXFP	16384 (16254)	512	80P6N-A	Mask ROM version
M38223M4MXXXGP			80P6S-A	Mask ROM version
M38223M4MXXXHP			80P6Q-A	Mask ROM version
M38224M6MXXXFP	24576 (24446)	640	80P6N-A	Mask ROM version
M38224M6MXXXHP			80P6Q-A	Mask ROM version

GROUP EXPANSION (H VERSION)

Mitsubishi plans to expand the 3822 group (H version) as follows:

Package

80P6N-A 0.8 mm-pitch plastic molded QFP
 80P6Q-A 0.5 mm-pitch plastic molded QFP

Memory Type

Support for Mask ROM version.

Memory Size

ROM size 16 K to 48 K bytes
 RAM size 512 to 1024 bytes

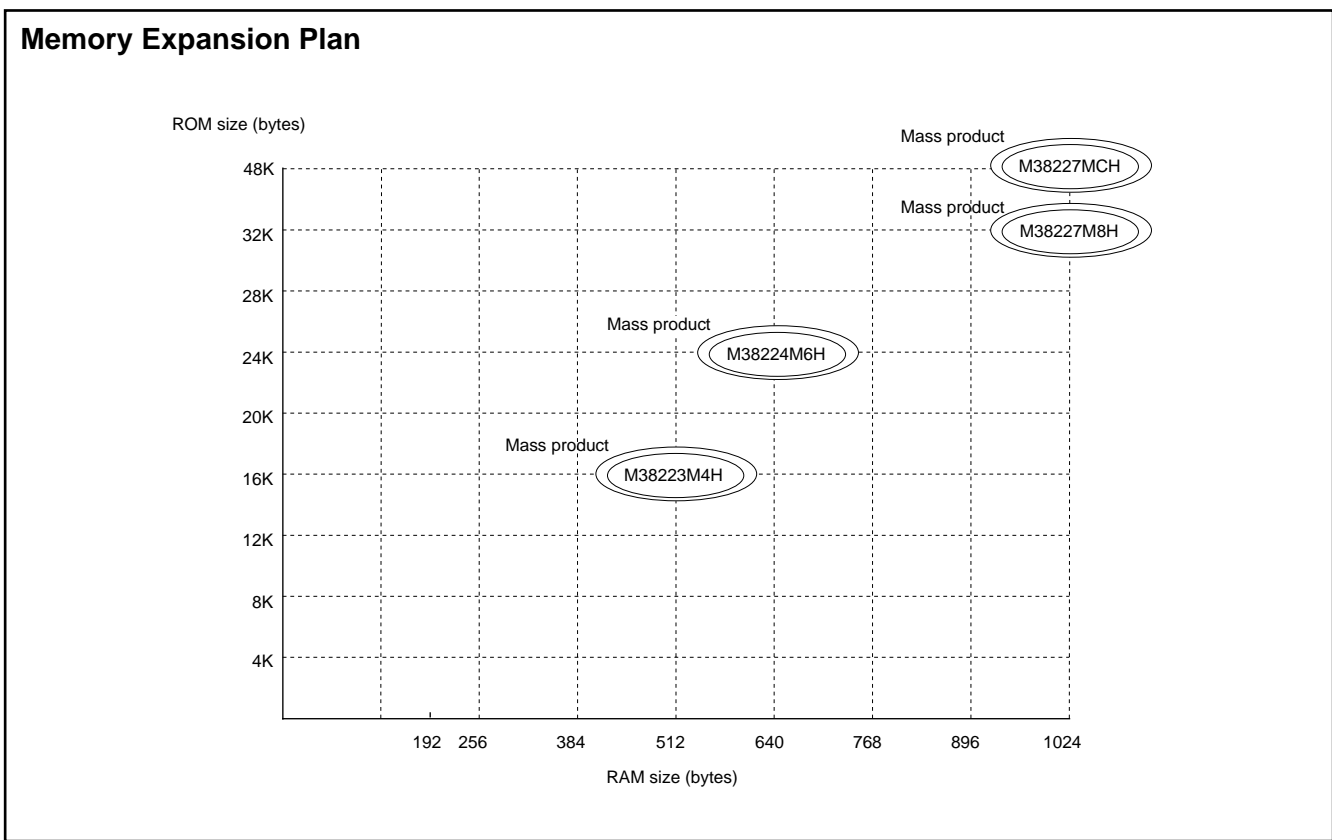

Fig. 8 Memory expansion plan for H version

Currently products are listed below.

Table 6 List of products for H version

As of August 2000

Product	ROM size (bytes) ROM size for User in ()	RAM size (bytes)	Package	Remarks
M38223M4HXXXFP	16384	512	80P6N-A	Mask ROM version
M38223M4HXXXHP	(16254)		80P6Q-A	Mask ROM version
M38224M6HXXXFP	24576	640	80P6N-A	Mask ROM version
M38224M6HXXXHP	(24446)		80P6Q-A	Mask ROM version
M38227M8HXXXFP	32768	1024	80P6N-A	Mask ROM version
M38227M8HXXXHP	(32638)		80P6Q-A	Mask ROM version
M38227MCHXXXFP	49152		80P6N-A	Mask ROM version
M38227MCHXXXHP	(49022)		80P6Q-A	Mask ROM version

**FUNCTIONAL DESCRIPTION
CENTRAL PROCESSING UNIT (CPU)**

The 3822 group uses the standard 740 family instruction set. Refer to the table of 740 family addressing modes and machine instructions or the 740 Family Software Manual for details on the instruction set.

Machine-resident 740 family instructions are as follows:
The FST and SLW instruction cannot be used.
The STP, WIT, MUL, and DIV instruction can be used.

[Accumulator (A)]

The accumulator is an 8-bit register. Data operations such as data transfer, etc., are executed mainly through the accumulator.

[Index Register X (X)]

The index register X is an 8-bit register. In the index addressing modes, the value of the OPERAND is added to the contents of register X and specifies the real address.

[Index Register Y (Y)]

The index register Y is an 8-bit register. In partial instruction, the value of the OPERAND is added to the contents of register Y and specifies the real address.

[Stack Pointer (S)]

The stack pointer is an 8-bit register used during subroutine calls and interrupts. This register indicates start address of stored area (stack) for storing registers during subroutine calls and interrupts. The low-order 8 bits of the stack address are determined by the contents of the stack pointer. The high-order 8 bits of the stack address are determined by the stack page selection bit. If the stack page selection bit is "0", the high-order 8 bits becomes "0016". If the stack page selection bit is "1", the high-order 8 bits becomes "0116".

The operations of pushing register contents onto the stack and popping them from the stack are shown in Figure 10.

Store registers other than those described in Figure 10 with program when the user needs them during interrupts or subroutine calls.

[Program Counter (PC)]

The program counter is a 16-bit counter consisting of two 8-bit registers PCH and PCL. It is used to indicate the address of the next instruction to be executed.

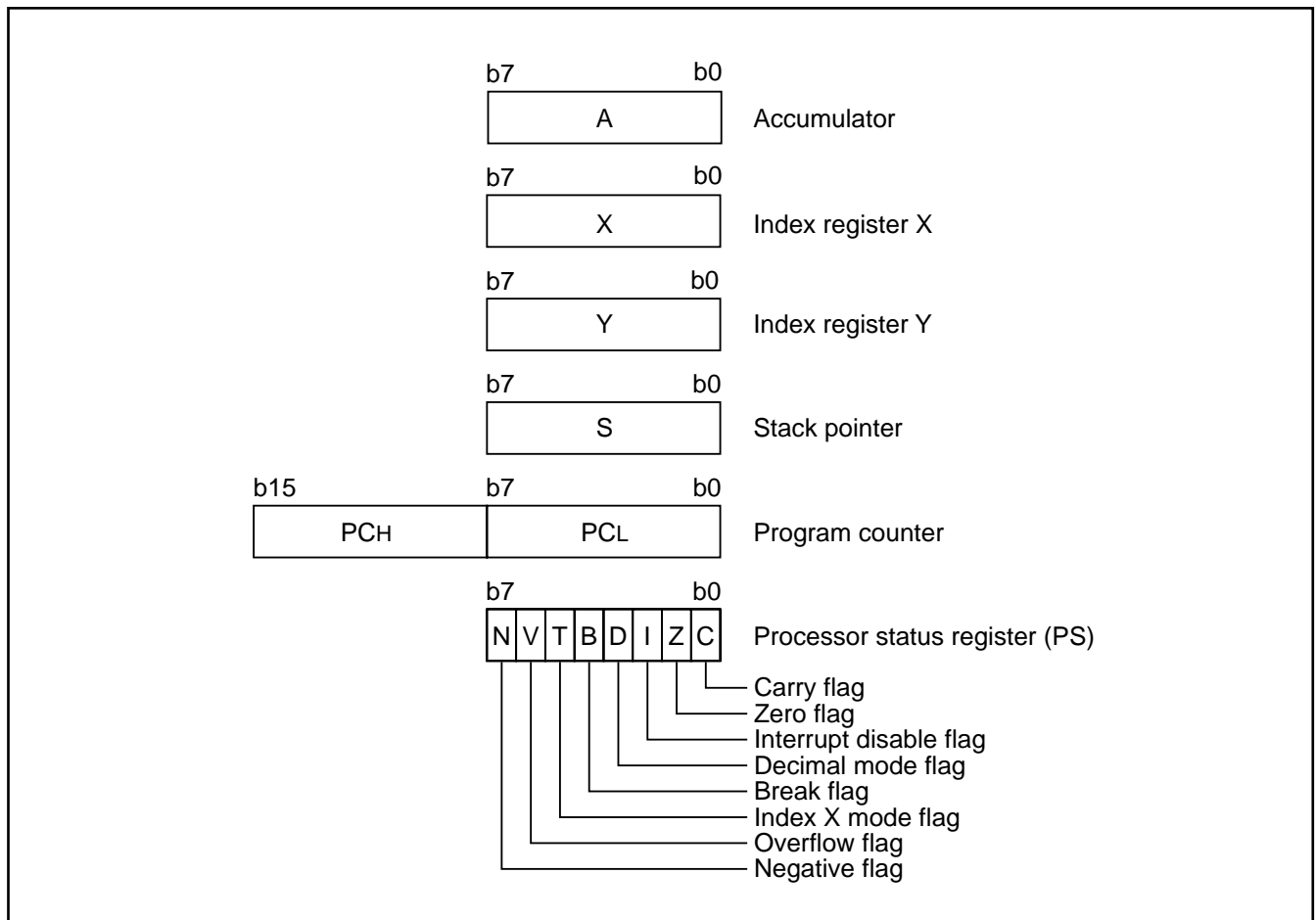

Fig.9 740 Family CPU register structure

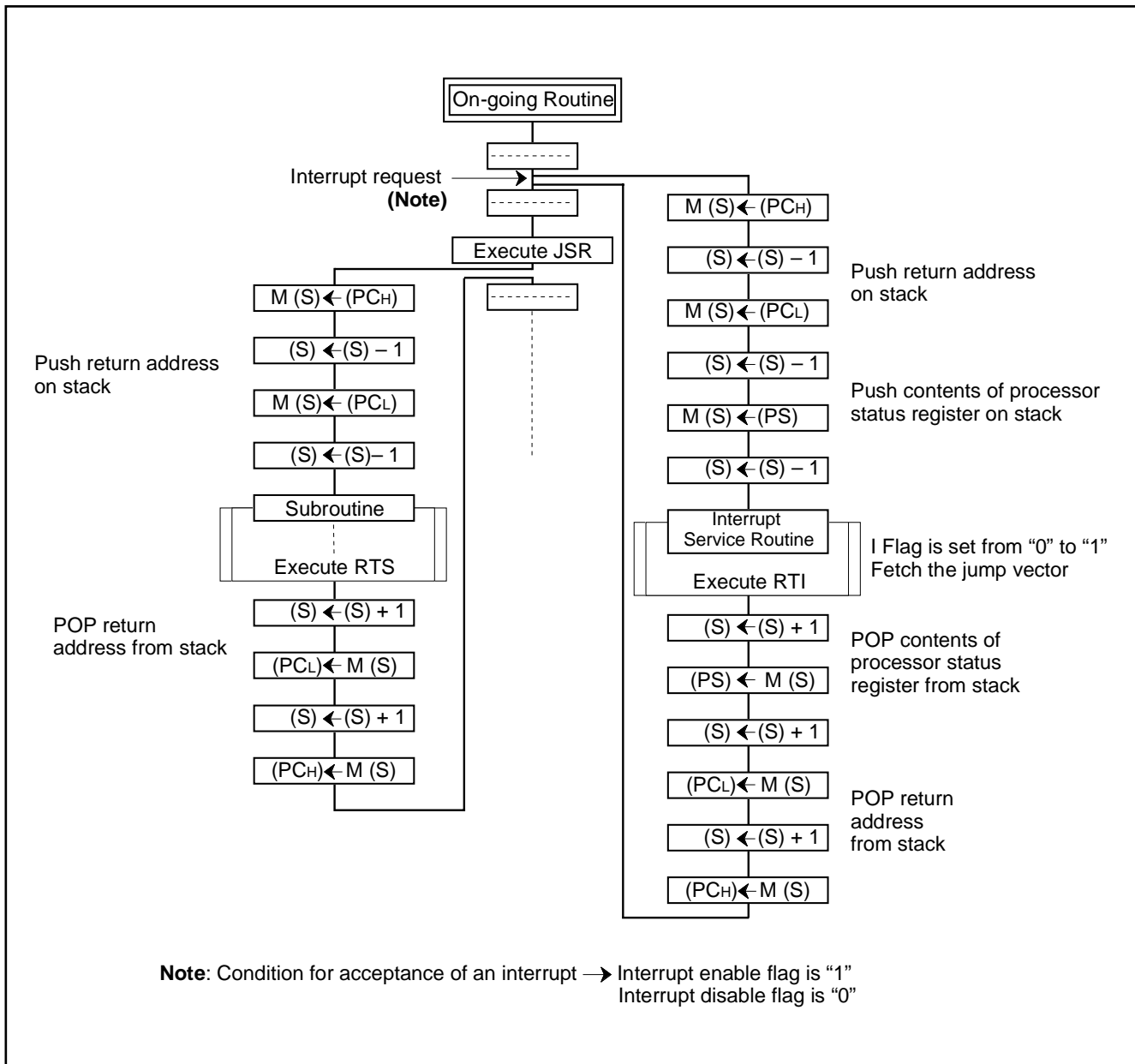

Fig. 10 Register push and pop at interrupt generation and subroutine call

Table 7 Push and pop instructions of accumulator or processor status register

	Push instruction to stack	Pop instruction from stack
Accumulator	PHA	PLA
Processor status register	PHP	PLP

[Processor status register (PS)]

The processor status register is an 8-bit register consisting of 5 flags which indicate the status of the processor after an arithmetic operation and 3 flags which decide MCU operation. Branch operations can be performed by testing the Carry (C) flag, Zero (Z) flag, Overflow (V) flag, or the Negative (N) flag. In decimal mode, the Z, V, N flags are not valid.

•Bit 0: Carry flag (C)

The C flag contains a carry or borrow generated by the arithmetic logic unit (ALU) immediately after an arithmetic operation. It can also be changed by a shift or rotate instruction.

•Bit 1: Zero flag (Z)

The Z flag is set if the result of an immediate arithmetic operation or a data transfer is "0", and cleared if the result is anything other than "0".

•Bit 2: Interrupt disable flag (I)

The I flag disables all interrupts except for the interrupt generated by the BRK instruction.

Interrupts are disabled when the I flag is "1".

•Bit 3: Decimal mode flag (D)

The D flag determines whether additions and subtractions are executed in binary or decimal. Binary arithmetic is executed when this flag is "0"; decimal arithmetic is executed when it is "1".

Decimal correction is automatic in decimal mode. Only the ADC and SBC instructions can be used for decimal arithmetic.

•Bit 4: Break flag (B)

The B flag is used to indicate that the current interrupt was generated by the BRK instruction. The BRK flag in the processor status register is always "0". When the BRK instruction is used to generate an interrupt, the processor status register is pushed onto the stack with the break flag set to "1".

•Bit 5: Index X mode flag (T)

When the T flag is "0", arithmetic operations are performed between accumulator and memory. When the T flag is "1", direct arithmetic operations and direct data transfers are enabled between memory locations.

•Bit 6: Overflow flag (V)

The V flag is used during the addition or subtraction of one byte of signed data. It is set if the result exceeds +127 to -128. When the BIT instruction is executed, bit 6 of the memory location operated on by the BIT instruction is stored in the overflow flag.

•Bit 7: Negative flag (N)

The N flag is set if the result of an arithmetic operation or data transfer is negative. When the BIT instruction is executed, bit 7 of the memory location operated on by the BIT instruction is stored in the negative flag.

Table 8 Set and clear instructions of each bit of processor status register

	C flag	Z flag	I flag	D flag	B flag	T flag	V flag	N flag
Set instruction	SEC	–	SEI	SED	–	SET	–	–
Clear instruction	CLC	–	CLI	CLD	–	CLT	CLV	–

[CPU Mode Register (CPUM)] 003B₁₆

The CPU mode register contains the stack page selection bit and the internal system clock selection bit.

The CPU mode register is allocated at address 003B₁₆.

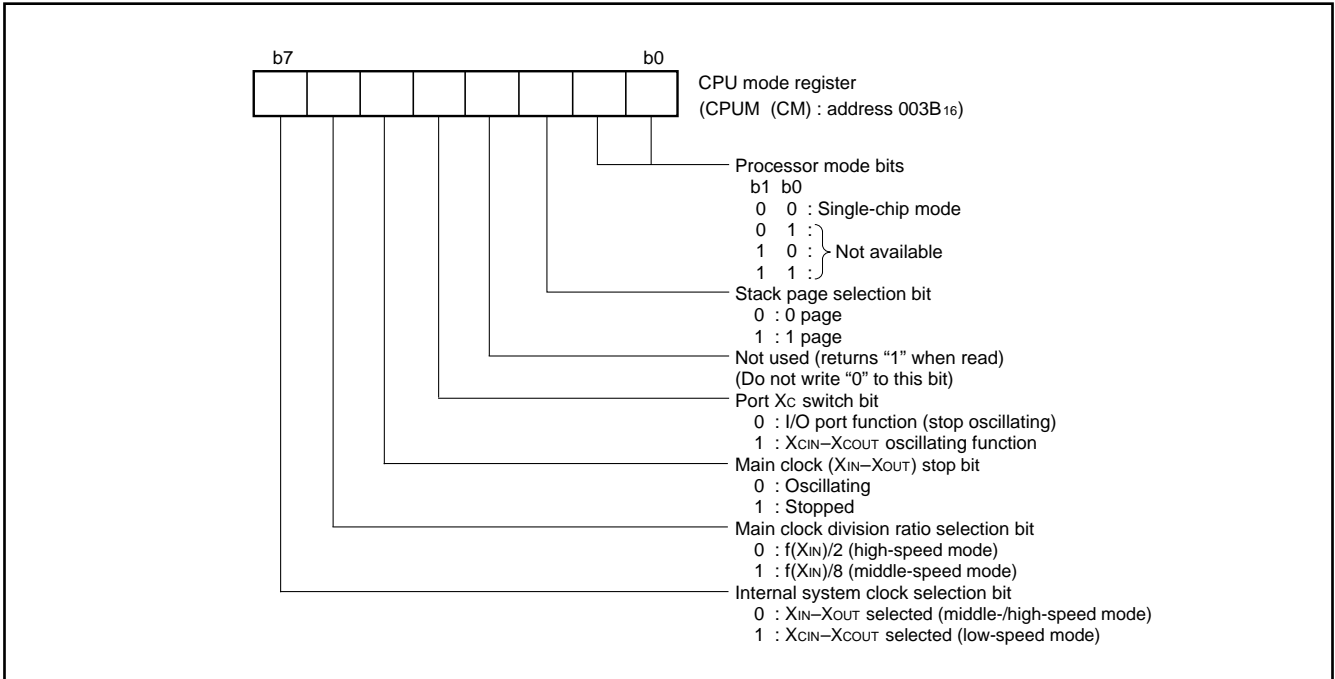

Fig. 11 Structure of CPU mode register

MEMORY

Special Function Register (SFR) Area

The Special Function Register area in the zero page contains control registers such as I/O ports and timers.

RAM

RAM is used for data storage and for stack area of subroutine calls and interrupts.

ROM

The first 128 bytes and the last 2 bytes of ROM are reserved for device testing and the rest is user area for storing programs.

Interrupt Vector Area

The interrupt vector area contains reset and interrupt vectors.

Zero Page

The 256 bytes from addresses 0000₁₆ to 00FF₁₆ are called the zero page area. The internal RAM and the special function register (SFR) are allocated to this area.

The zero page addressing mode can be used to specify memory and register addresses in the zero page area. Access to this area with only 2 bytes is possible in the zero page addressing mode.

Special Page

The 256 bytes from addresses FF00₁₆ to FFFF₁₆ are called the special page area. The special page addressing mode can be used to specify memory addresses in the special page area. Access to this area with only 2 bytes is possible in the special page addressing mode.

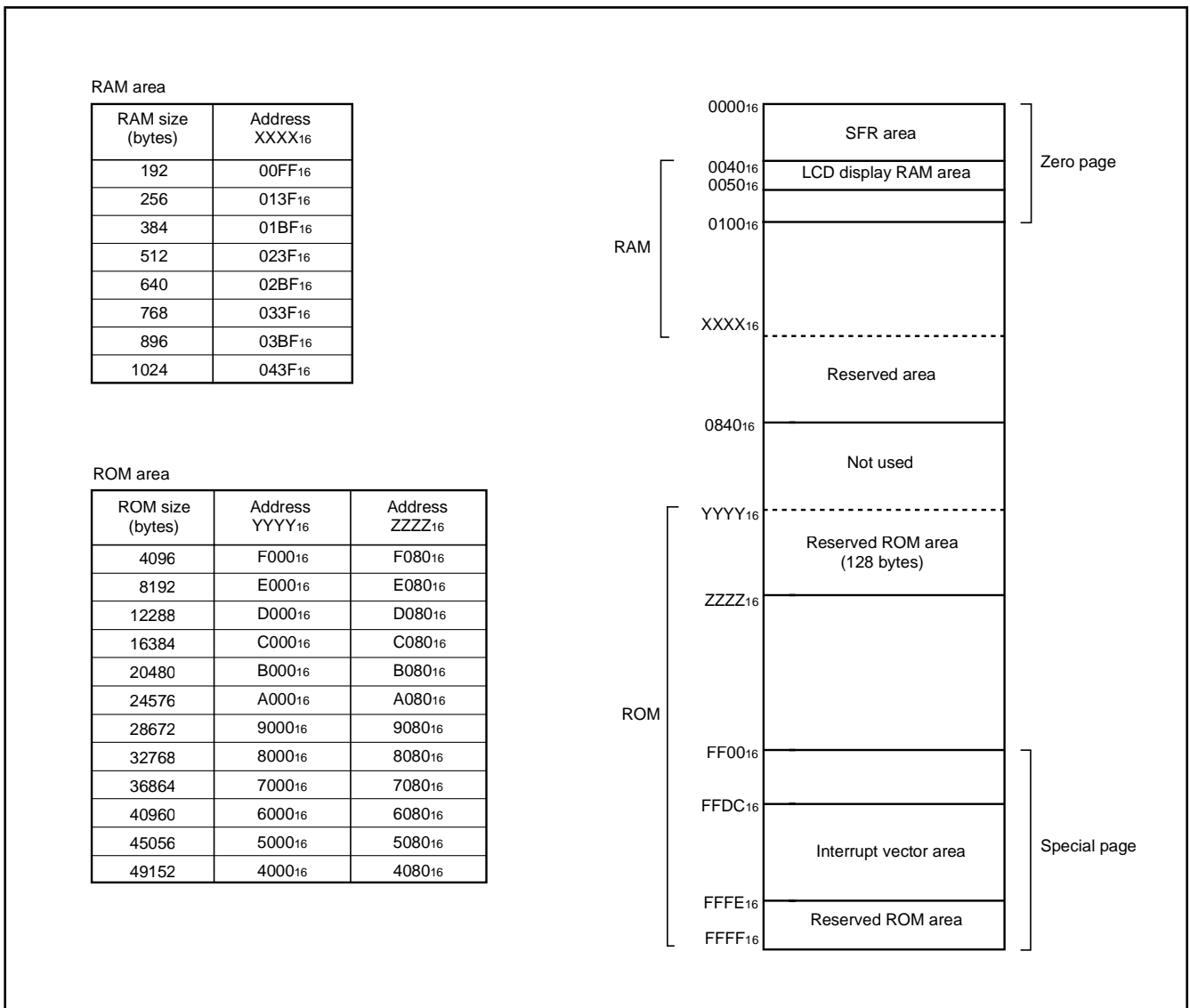

Fig. 12 Memory map diagram

0000 ₁₆	Port P0 (P0)	0020 ₁₆	Timer X (low) (TXL)
0001 ₁₆	Port P0 direction register (P0D)	0021 ₁₆	Timer X (high) (TXH)
0002 ₁₆	Port P1 (P1)	0022 ₁₆	Timer Y (low) (TYL)
0003 ₁₆	Port P1 output control register (P1D)	0023 ₁₆	Timer Y (high) (TYH)
0004 ₁₆	Port P2 (P2)	0024 ₁₆	Timer 1 (T1)
0005 ₁₆	Port P2 direction register (P2D)	0025 ₁₆	Timer 2 (T2)
0006 ₁₆	Port P3 (P3)	0026 ₁₆	Timer 3 (T3)
0007 ₁₆		0027 ₁₆	Timer X mode register (TXM)
0008 ₁₆	Port P4 (P4)	0028 ₁₆	Timer Y mode register (TYM)
0009 ₁₆	Port P4 direction register (P4D)	0029 ₁₆	Timer 123 mode register (T123M)
000A ₁₆	Port P5 (P5)	002A ₁₆	φ output control register (CKOUT)
000B ₁₆	Port P5 direction register (P5D)	002B ₁₆	
000C ₁₆	Port P6 (P6)	002C ₁₆	
000D ₁₆	Port P6 direction register (P6D)	002D ₁₆	
000E ₁₆	Port P7 (P7)	002E ₁₆	
000F ₁₆	Port P7 direction register (P7D)	002F ₁₆	
0010 ₁₆		0030 ₁₆	
0011 ₁₆		0031 ₁₆	
0012 ₁₆		0032 ₁₆	
0013 ₁₆		0033 ₁₆	
0014 ₁₆		0034 ₁₆	A-D control register (ADCON)
0015 ₁₆		0035 ₁₆	A-D conversion register (AD)
0016 ₁₆	PULL register A (PULLA)	0036 ₁₆	
0017 ₁₆	PULL register B (PULLB)	0037 ₁₆	
0018 ₁₆	Transmit/Receive buffer register (TB/RB)	0038 ₁₆	Segment output enable register (SEG)
0019 ₁₆	Serial I/O status register (SIOSTS)	0039 ₁₆	LCD mode register (LM)
001A ₁₆	Serial I/O control register (SIO1CON)	003A ₁₆	Interrupt edge selection register (INTEDGE)
001B ₁₆	UART control register (UARTCON)	003B ₁₆	CPU mode register (CPUM)
001C ₁₆	Baud rate generator (BRG)	003C ₁₆	Interrupt request register 1 (IREQ1)
001D ₁₆		003D ₁₆	Interrupt request register 2 (IREQ2)
001E ₁₆		003E ₁₆	Interrupt control register 1 (ICON1)
001F ₁₆		003F ₁₆	Interrupt control register 2 (ICON2)

Fig. 13 Memory map of special function register (SFR)

I/O PORTS

Direction Registers (ports P2, P41-P47, and P5-P7)

The 3822 group has 49 programmable I/O pins arranged in seven I/O ports (ports P0-P2, P41-P47 and P5-P7). The I/O ports P2, P41-P47 and P5-P7 have direction registers which determine the input/output direction of each individual pin. Each bit in a direction register corresponds to one pin, and each pin can be set to be input port or output port.

When "0" is written to the bit corresponding to a pin, that pin becomes an input pin. When "1" is written to that bit, that pin becomes an output pin.

If data is read from a pin set to output, the value of the port output latch is read, not the value of the pin itself. Pins set to input are floating. If a pin set to input is written to, only the port output latch is written to and the pin remains floating.

Direction Registers (ports P0 and P1)

Ports P0 and P1 have direction registers which determine the input/output direction of each individual port.

Each port in a direction register corresponds to one port, each port can be set to be input or output. When "0" is written to the bit 0 of a direction register, that port becomes an input port. When "1" is written to that port, that port becomes an output port. Bits 1 to 7 of ports P0 and P1 direction registers are not used.

Ports P3 and P40

These ports are only for input.

Pull-up/Pull-down Control

By setting the PULL register A (address 0016₁₆) or the PULL register B (address 0017₁₆), ports except for port P40 can control either pull-down or pull-up (pins that are shared with the segment output pins for LCD are pull-down; all other pins are pull-up) with a program.

However, the contents of PULL register A and PULL register B do not affect ports programmed as the output ports.

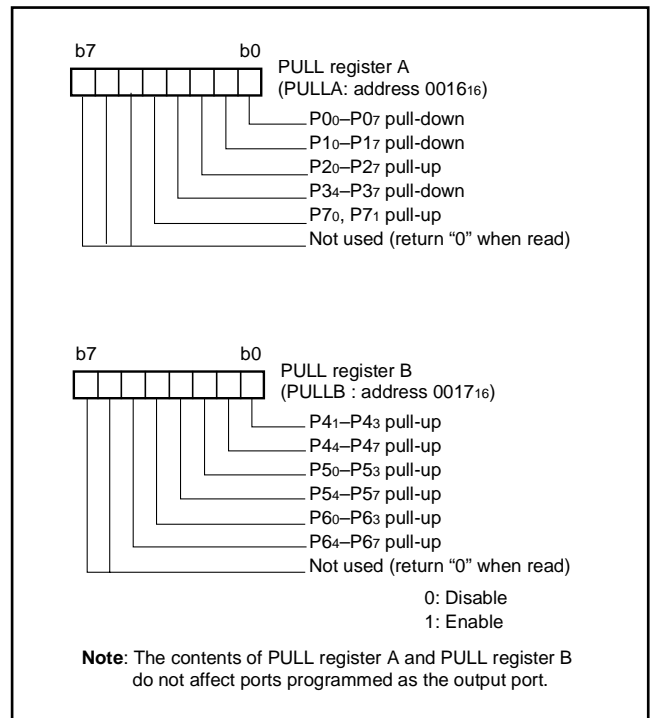

Fig. 14 Structure of PULL register A and PULL register B

Table 9 List of I/O port function

Pin	Name	Input/Output	I/O Format	Non-Port Function	Related SFRs	Diagram No.		
P00/SEG16– P07/SEG23	Port P0	Input/output, individual ports	CMOS compatible input level CMOS 3-state output	LCD segment output	PULL register A Segment output enable register	(1)		
P10/SEG24– P17/SEG31								
P20–P27	Port P2	Input/output, individual bits	CMOS compatible input level CMOS 3-state output	Key input (key-on wake-up) interrupt input	PULL register A Interrupt control register 2	(2)		
P34/SEG12– P37/SEG15	Port P3	Input	CMOS compatible input level	LCD segment output	PULL register A Segment output enable register	(3)		
P40	Port P4	Input	CMOS compatible input level			(4)		
P41/φ		Input/output, individual bits	CMOS compatible input level CMOS 3-state output	φ clock output	PULL register B φ output control register	(5)		
P42/INT0, P43/INT1				External interrupt input	PULL register B Interrupt edge selection register	(2)		
P44/RxD				Serial I/O function I/O	PULL register B Serial I/O control register Serial I/O status register UART control register		(6)	
P45/TxD							(7)	
P46/SCLK							(8)	
P47/SRDY							(9)	
P50/INT2, P51/INT3				Port P5	Input/output, individual bits	CMOS compatible input level CMOS 3-state output	External interrupt input	PULL register B Interrupt edge selection register
P52/RTP0, P53/RTP1	Real time port function output						PULL register B Timer X mode register	(10)
P54/CNTR0	Timer X function I/O	PULL register B Timer X mode register	(11)					
P55/CNTR1	Timer Y function input	PULL register B Timer Y mode register	(12)					
P56/TOUT	Timer 2 function output	PULL register B Timer 123 mode register	(13)					
P57/ADT	A-D trigger input	PULL register B A-D control register	(12)					
P60/AN0– P67/AN7	Port P6		Input/output, individual bits	CMOS compatible input level CMOS 3-state output	A-D conversion input	(14)		
P70/XCOUT	Port P7	Input/output, individual bits	CMOS compatible input level CMOS 3-state output	Sub-clock generating circuit I/O	PULL register A CPU mode register	(15)		
P71/XCIN						(16)		
COM0–COM3	Common	Output	LCD common output		LCD mode register	(17)		
SEG0–SEG11	Segment	Output	LCD segment output			(18)		

Notes1: How to use double-function ports as function I/O ports, refer to the applicable sections.

2: Make sure that the input level at each pin is either 0 V or V_{CC} during execution of the STP instruction. When an input level is at an intermediate potential, a current will flow V_{CC} to V_{SS} through the input-stage gate.

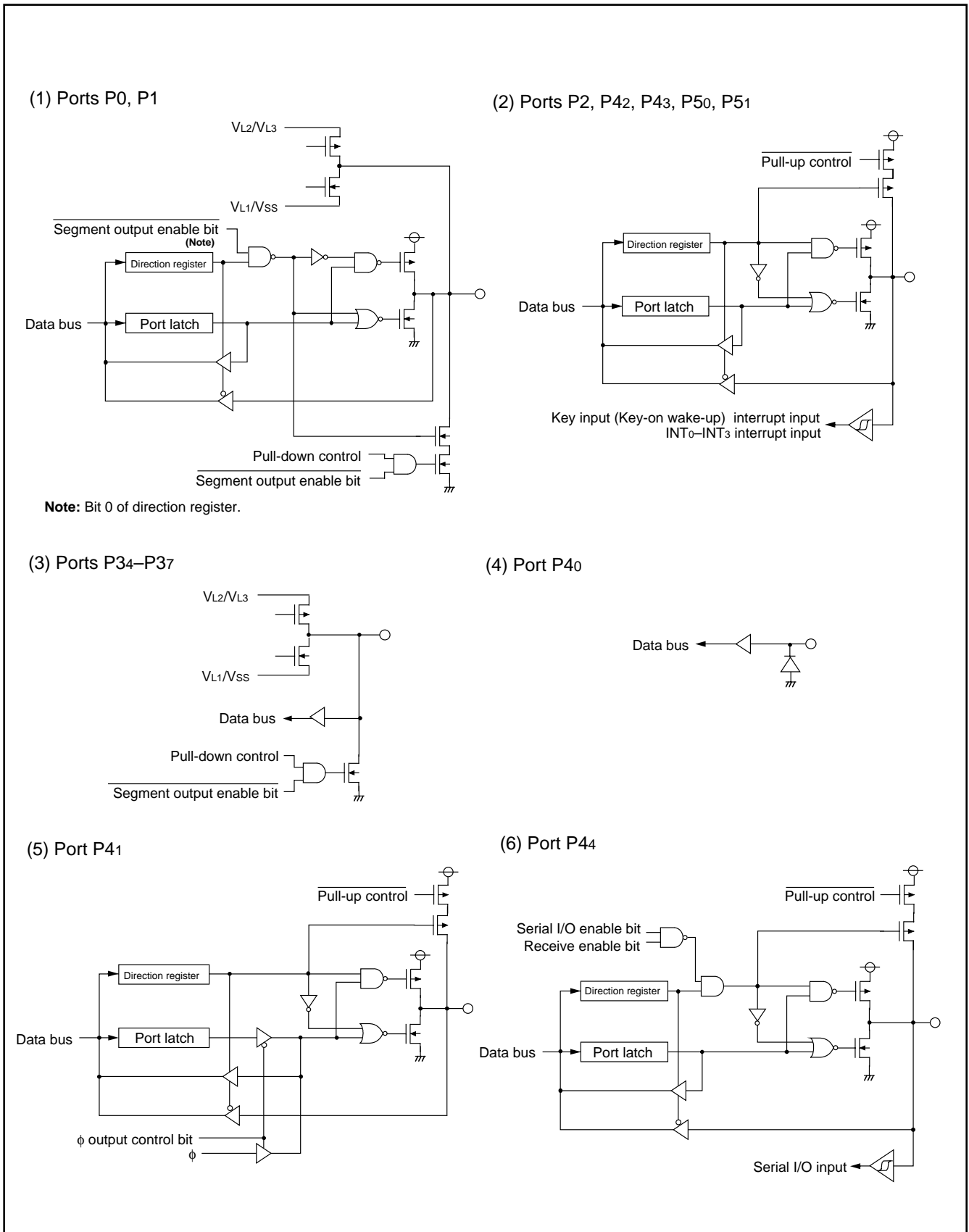

Fig. 15 Port block diagram (1)

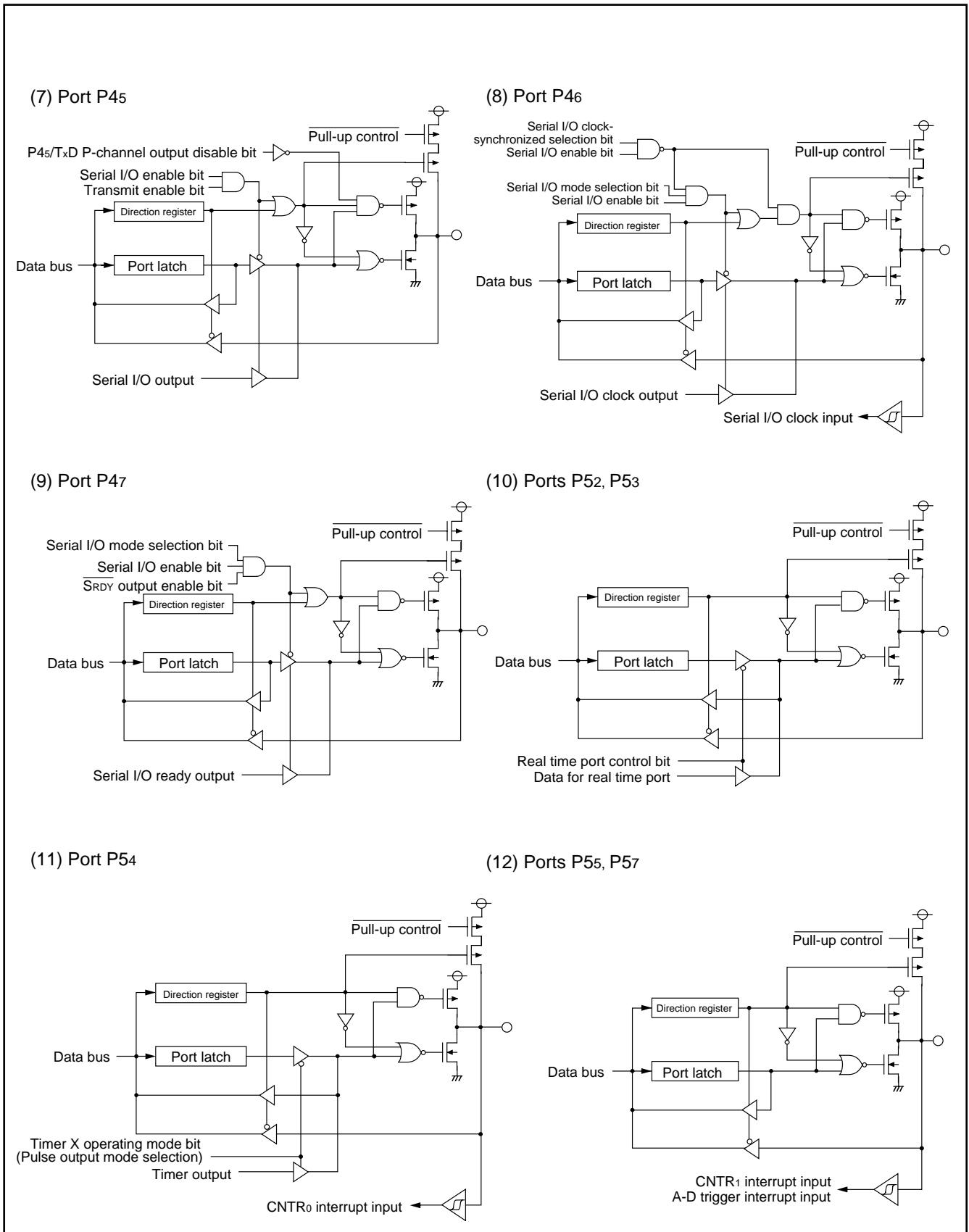

Fig. 16 Port block diagram (2)

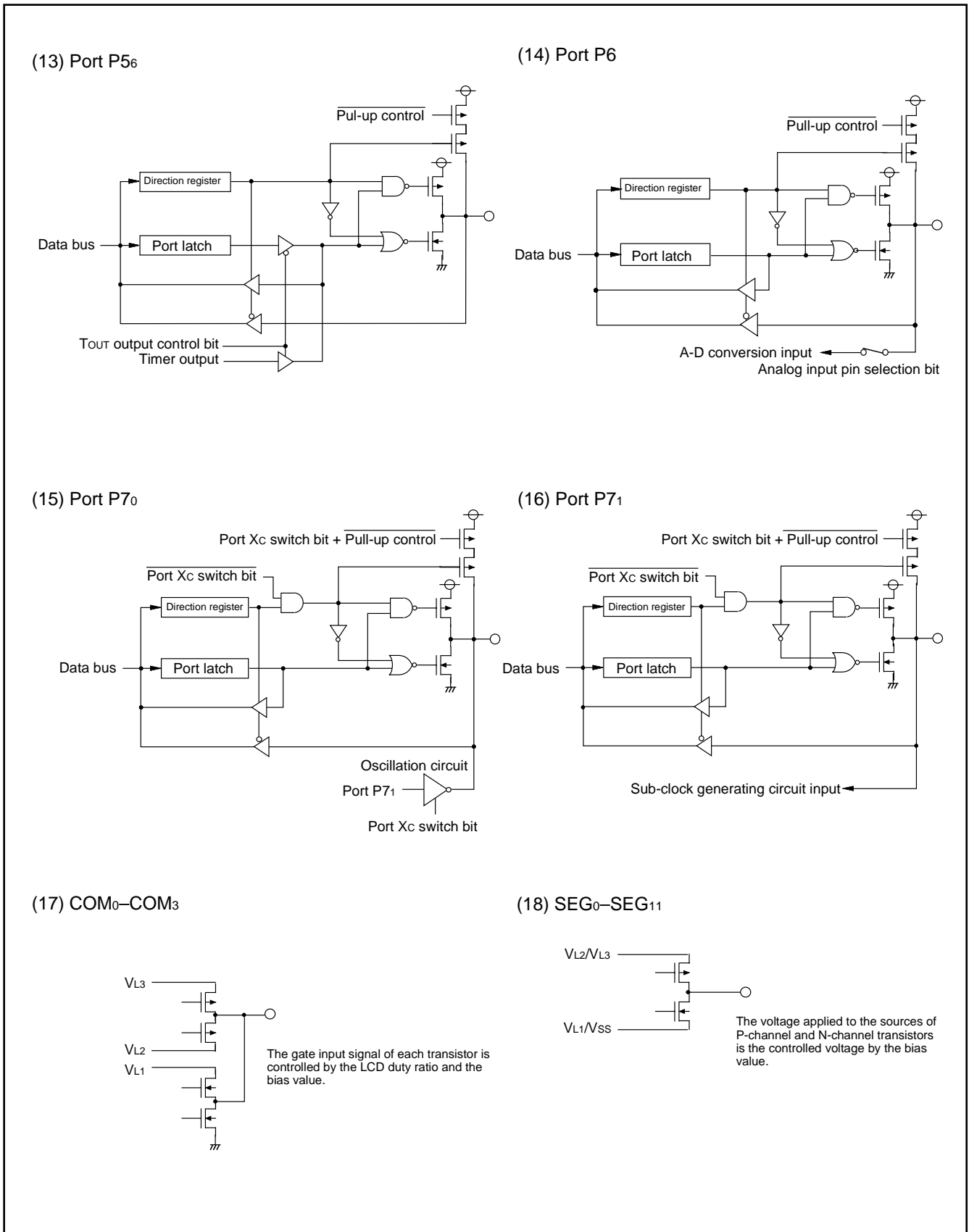

Fig. 17 Port block diagram (3)

INTERRUPTS

Interrupts occur by seventeen sources: eight external, eight internal, and one software.

Interrupt Control

Each interrupt is controlled by an interrupt request bit, an interrupt enable bit, and the interrupt disable flag except for the software interrupt set by the BRK instruction. An interrupt occurs if the corresponding interrupt request and enable bits are "1" and the interrupt disable flag is "0".

Interrupt enable bits can be set or cleared by software.

Interrupt request bits can be cleared by software, but cannot be set by software.

The BRK instruction cannot be disabled with any flag or bit. The I flag disables all interrupts except the BRK instruction interrupt.

When several interrupts occur at the same time, the interrupts are received according to priority.

Interrupt Operation

Upon acceptance of an interrupt the following operations are automatically performed:

1. The contents of the program counter and processor status register are automatically pushed onto the stack.

2. The interrupt disable flag is set and the corresponding interrupt request bit is cleared.

3. The interrupt jump destination address is read from the vector table into the program counter.

■Notes on interrupts

When setting the followings, the interrupt request bit may be set to "1".

- When setting external interrupt active edge

Related register: Interrupt edge selection register (address 3A16)

Timer X mode register (address 2716)

Timer Y mode register (address 2816)

- When switching interrupt sources of an interrupt vector address where two or more interrupt sources are allocated

Related register: A-D control register (address 3416)

When not requiring for the interrupt occurrence synchronized with these setting, take the following sequence.

- ①Set the corresponding interrupt enable bit to "0" (disabled).
- ②Set the interrupt edge select bit or the interrupt source select bit to "1".
- ③Set the corresponding interrupt request bit to "0" after 1 or more instructions have been executed.
- ④Set the corresponding interrupt enable bit to "1" (enabled).

Table 10 Interrupt vector addresses and priority

Interrupt Source	Priority	Vector Addresses (Note 1)		Interrupt Request Generating Conditions	Remarks
		High	Low		
Reset (Note 2)	1	FFFD ₁₆	FFFC ₁₆	At reset	Non-maskable
INT ₀	2	FFFB ₁₆	FFFA ₁₆	At detection of either rising or falling edge of INT ₀ input	External interrupt (active edge selectable)
INT ₁	3	FFF9 ₁₆	FFF8 ₁₆	At detection of either rising or falling edge of INT ₁ input	External interrupt (active edge selectable)
Serial I/O reception	4	FFF7 ₁₆	FFF6 ₁₆	At completion of serial I/O data reception	Valid when serial I/O is selected
Serial I/O transmission	5	FFF5 ₁₆	FFF4 ₁₆	At completion of serial I/O transmit shift or when transmission buffer is empty	Valid when serial I/O is selected
Timer X	6	FFF3 ₁₆	FFF2 ₁₆	At timer X underflow	
Timer Y	7	FFF1 ₁₆	FFF0 ₁₆	At timer Y underflow	
Timer 2	8	FFEF ₁₆	FFEE ₁₆	At timer 2 underflow	
Timer 3	9	FFED ₁₆	FFEC ₁₆	At timer 3 underflow	
CNTR ₀	10	FFEB ₁₆	FFEA ₁₆	At detection of either rising or falling edge of CNTR ₀ input	External interrupt (active edge selectable)
CNTR ₁	11	FFE9 ₁₆	FFE8 ₁₆	At detection of either rising or falling edge of CNTR ₁ input	External interrupt (active edge selectable)
Timer 1	12	FFE7 ₁₆	FFE6 ₁₆	At timer 1 underflow	
INT ₂	13	FFE5 ₁₆	FFE4 ₁₆	At detection of either rising or falling edge of INT ₂ input	External interrupt (active edge selectable)
INT ₃	14	FFE3 ₁₆	FFE2 ₁₆	At detection of either rising or falling edge of INT ₃ input	External interrupt (active edge selectable)
Key input (Key-on wake-up)	15	FFE1 ₁₆	FFE0 ₁₆	At falling of conjunction of input level for port P2 (at input mode)	External interrupt (Valid at falling)
ADT	16	FFDF ₁₆	FFDE ₁₆	At falling of ADT input	Valid when ADT interrupt is selected, External interrupt (Valid at falling)
A-D conversion				At completion of A-D conversion	Valid when A-D interrupt is selected
BRK instruction	17	FFDD ₁₆	FFDC ₁₆	At BRK instruction execution	Non-maskable software interrupt

Notes1: Vector addresses contain interrupt jump destination addresses.

2: Reset function in the same way as an interrupt with the highest priority.

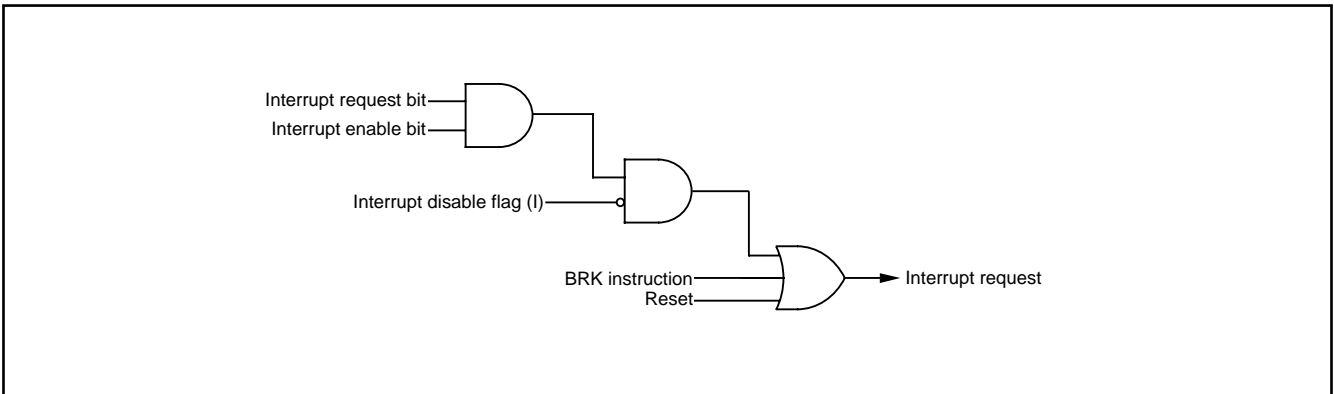

Fig. 18 Interrupt control

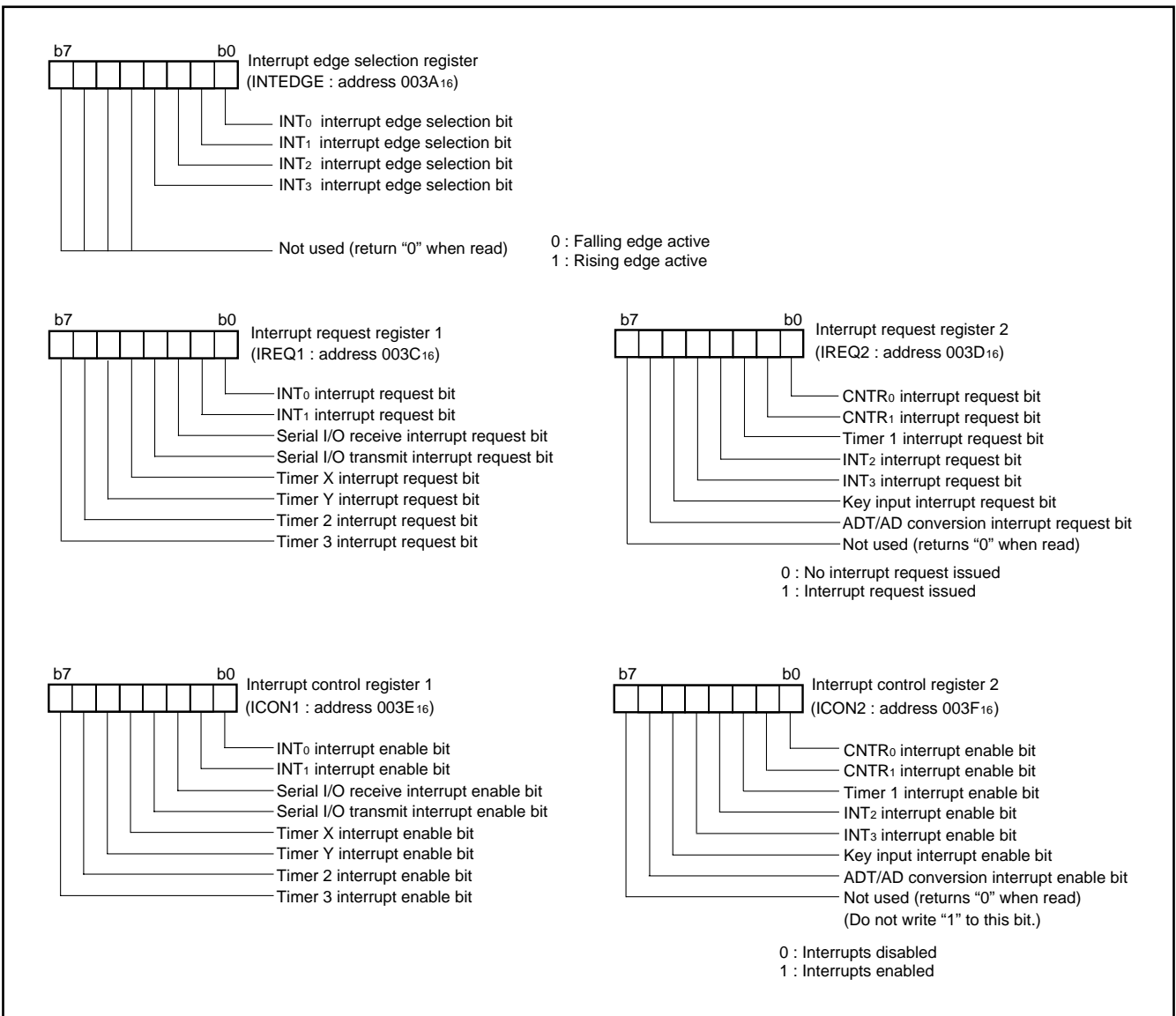

Fig. 19 Structure of interrupt-related registers

Key Input Interrupt (Key-on wake-up)

A Key-on wake-up interrupt request is generated by applying a falling edge to any pin of port P2 that have been set to input mode. In other words, it is generated when AND of input level goes from

"1" to "0". An example of using a key input interrupt is shown in Figure 20, where an interrupt request is generated by pressing one of the keys consisted as an active-low key matrix which inputs to ports P20–P23.

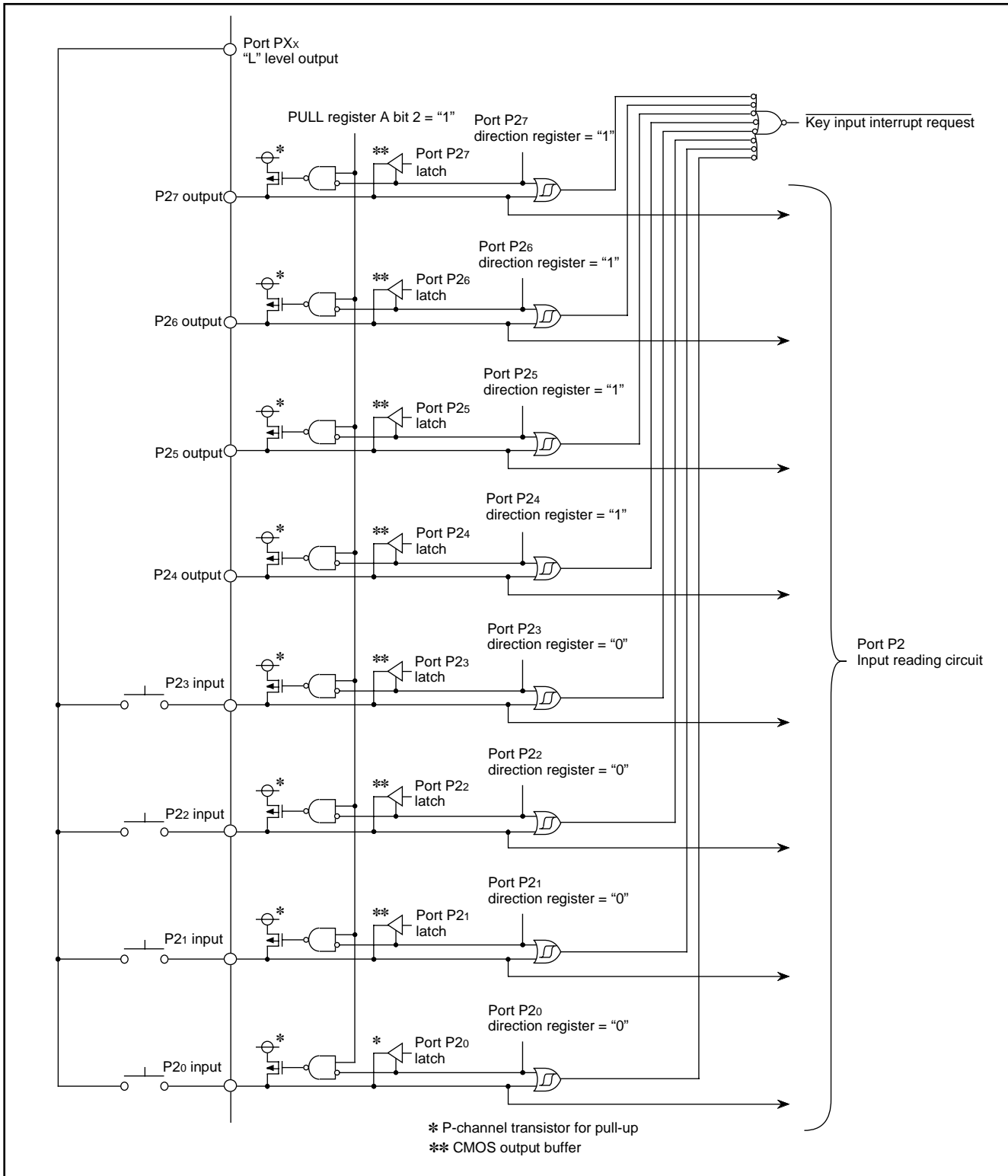

Fig. 20 Connection example when using key input interrupt and port P2 block diagram

TIMERS

The 3822 group has five timers: timer X, timer Y, timer 1, timer 2, and timer 3. Timer X and timer Y are 16-bit timers, and timer 1, timer 2, and timer 3 are 8-bit timers.

All timers are down count timers. When the timer reaches "0016", an underflow occurs at the next count pulse and the corresponding timer latch is reloaded into the timer and the count is continued. When a timer underflows, the interrupt request bit cor-

responding to that timer is set to "1".

Read and write operation on 16-bit timer must be performed for both high and low-order bytes. When reading a 16-bit timer, read the high-order byte first. When writing to a 16-bit timer, write the low-order byte first. The 16-bit timer cannot perform the correct operation when reading during the write operation, or when writing during the read operation.

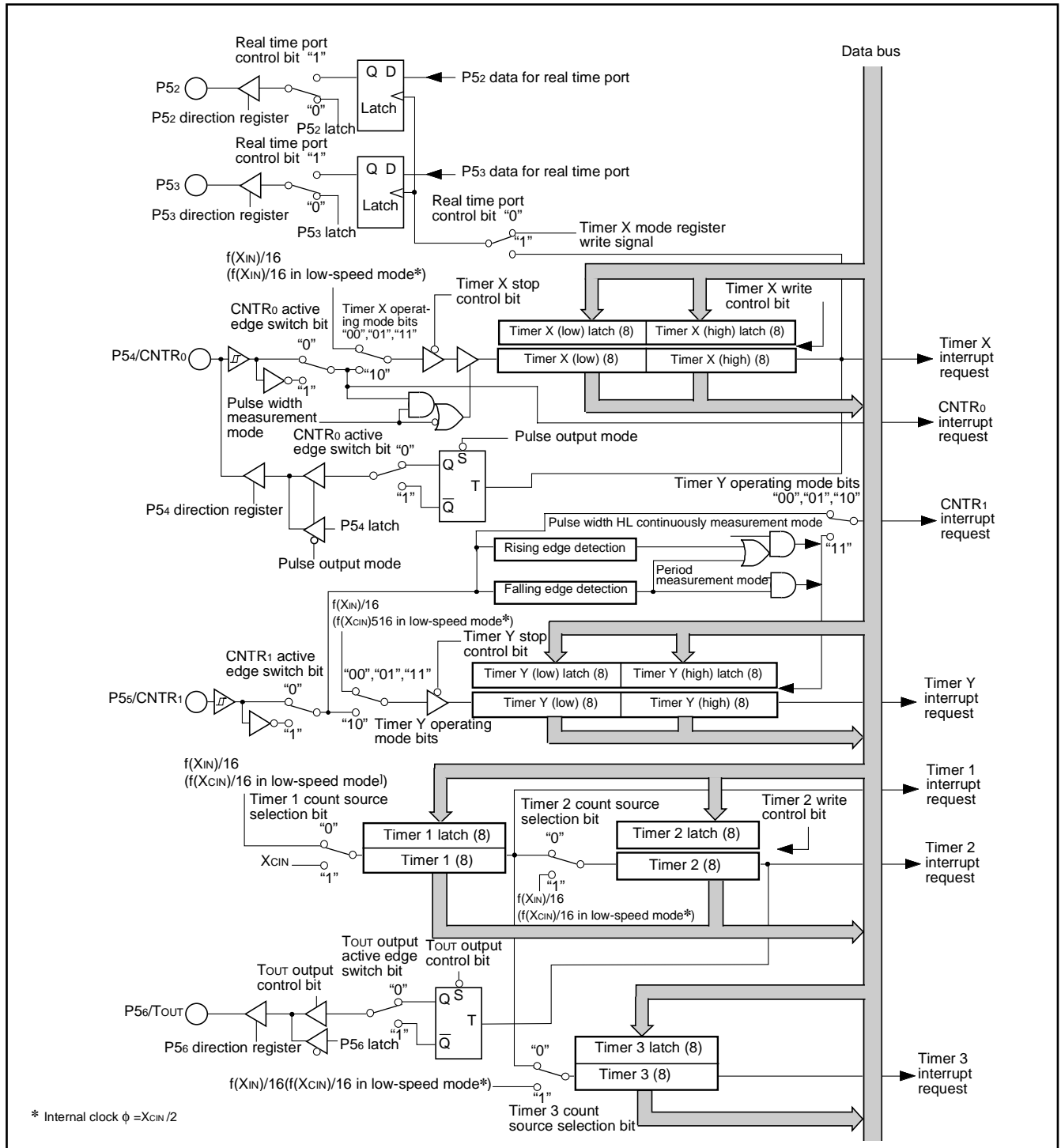

Fig. 21 Timer block diagram

Timer X

Timer X is a 16-bit timer that can be selected in one of four modes and can be controlled the timer X write and the real time port by setting the timer X mode register.

(1) Timer Mode

The timer counts $f(X_{IN})/16$ (or $f(X_{CIN})/16$ in low-speed mode).

(2) Pulse Output Mode

Each time the timer underflows, a signal output from the CNTR₀ pin is inverted. Except for this, the operation in pulse output mode is the same as in timer mode. When using a timer in this mode, set the corresponding port P54 direction register to output mode.

(3) Event Counter Mode

The timer counts signals input through the CNTR₀ pin. Except for this, the operation in event counter mode is the same as in timer mode. When using a timer in this mode, set the corresponding port P54 direction register to input mode.

(4) Pulse Width Measurement Mode

The count source is $f(X_{IN})/16$ (or $f(X_{CIN})/16$ in low-speed mode). If CNTR₀ active edge switch bit is "0", the timer counts while the input signal of CNTR₀ pin is at "H". If it is "1", the timer counts while the input signal of CNTR₀ pin is at "L". When using a timer in this mode, set the corresponding port P54 direction register to input mode.

●Timer X write control

If the timer X write control bit is "0", when the value is written in the address of timer X, the value is loaded in the timer X and the latch at the same time.

If the timer X write control bit is "1", when the value is written in the address of timer X, the value is loaded only in the latch. The value in the latch is loaded in timer X after timer X underflows.

If the value is written in latch only, when writing in the timer latch at the timer underflow, the value is set in the timer and the latch at one time. Additionally, unexpected value may be set in the high-order counter when the writing in high-order latch and the underflow of timer X are performed at the same timing.

●Real time port control

While the real time port function is valid, data for the real time port are output from ports P52 and P53 each time the timer X underflows. (However, after rewriting a data for real time port, if the real time port control bit is changed from "0" to "1", data are output independent of the timer X operation.) If the data for the real time port is changed while the real time port function is valid, the changed data are output at the next underflow of timer X.

Before using this function, set the corresponding port direction registers to output mode.

■Note on CNTR₀ interrupt active edge selection

CNTR₀ interrupt active edge depends on the CNTR₀ active edge switch bit.

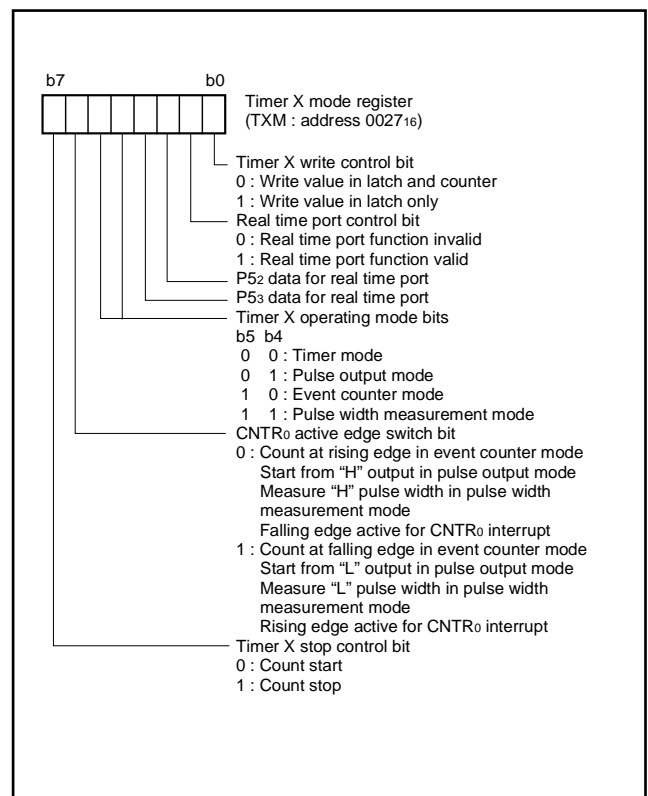

Fig. 22 Structure of timer X mode register

Timer Y

Timer Y is a 16-bit timer that can be selected in one of four modes.

(1) Timer Mode

The timer counts $f(X_{IN})/16$ (or $f(X_{CIN})/16$ in low-speed mode).

(2) Period Measurement Mode

CNTR1 interrupt request is generated at rising/falling edge of CNTR1 pin input signal. Simultaneously, the value in timer Y latch is reloaded in timer Y and timer Y continues counting down. Except for the above-mentioned, the operation in period measurement mode is the same as in timer mode.

The timer value just before the reloading at rising/falling of CNTR1 pin input signal is retained until the timer Y is read once after the reload.

The rising/falling timing of CNTR1 pin input signal is found by CNTR1 interrupt. When using a timer in this mode, set the corresponding port P55 direction register to input mode.

(3) Event Counter Mode

The timer counts signals input through the CNTR1 pin.

Except for this, the operation in event counter mode is the same as in timer mode. When using a timer in this mode, set the corresponding port P55 direction register to input mode.

(4) Pulse Width HL Continuously Measurement Mode

CNTR1 interrupt request is generated at both rising and falling edges of CNTR1 pin input signal. Except for this, the operation in pulse width HL continuously measurement mode is the same as in period measurement mode. When using a timer in this mode, set the corresponding port P55 direction register to input mode.

■Note on CNTR1 interrupt active edge selection

CNTR1 interrupt active edge depends on the CNTR1 active edge switch bit. However, in pulse width HL continuously measurement mode, CNTR1 interrupt request is generated at both rising and falling edges of CNTR1 pin input signal regardless of the setting of CNTR1 active edge switch bit.

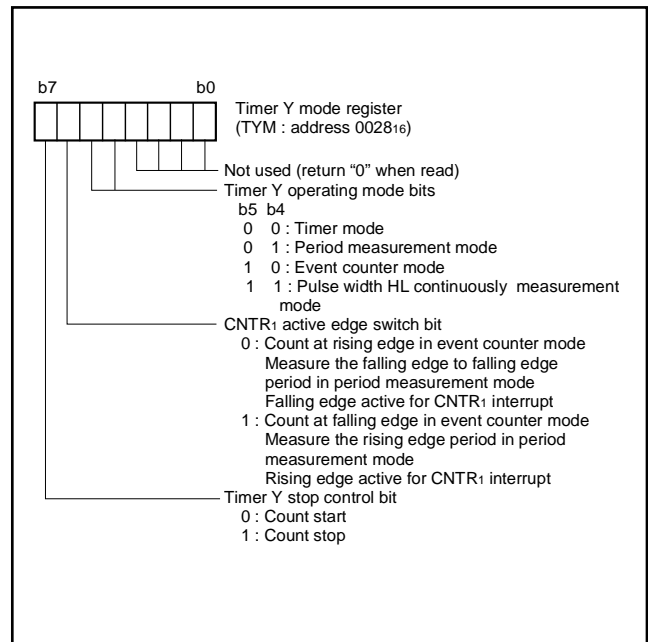

Fig. 23 Structure of timer Y mode register

Timer 1, Timer 2, Timer 3

Timer 1, timer 2, and timer 3 are 8-bit timers. The count source for each timer can be selected by timer 123 mode register. The timer latch value is not affected by a change of the count source. However, because changing the count source may cause an inadvertent count down of the timer, rewrite the value of timer whenever the count source is changed.

●**Timer 2 write control**

If the timer 2 write control bit is "0", when the value is written in the address of timer 2, the value is loaded in the timer 2 and the latch at the same time.

If the timer 2 write control bit is "1", when the value is written in the address of timer 2, the value is loaded only in the latch. The value in the latch is loaded in timer 2 after timer 2 underflows.

●**Timer 2 output control**

When the timer 2 (TOUT) is output enabled, an inversion signal from the TOUT pin is output each time timer 2 underflows.

In this case, set the port shared with the TOUT pin to the output mode.

■**Notes on timer 1 to timer 3**

When the count source of timer 1 to 3 is changed, the timer counting value may be changed large because a thin pulse is generated in count input of timer. If timer 1 output is selected as the count source of timer 2 or timer 3, when timer 1 is written, the counting value of timer 2 or timer 3 may be changed large because a thin pulse is generated in timer 1 output.

Therefore, set the value of timer in the order of timer 1, timer 2 and timer 3 after the count source selection of timer 1 to 3.

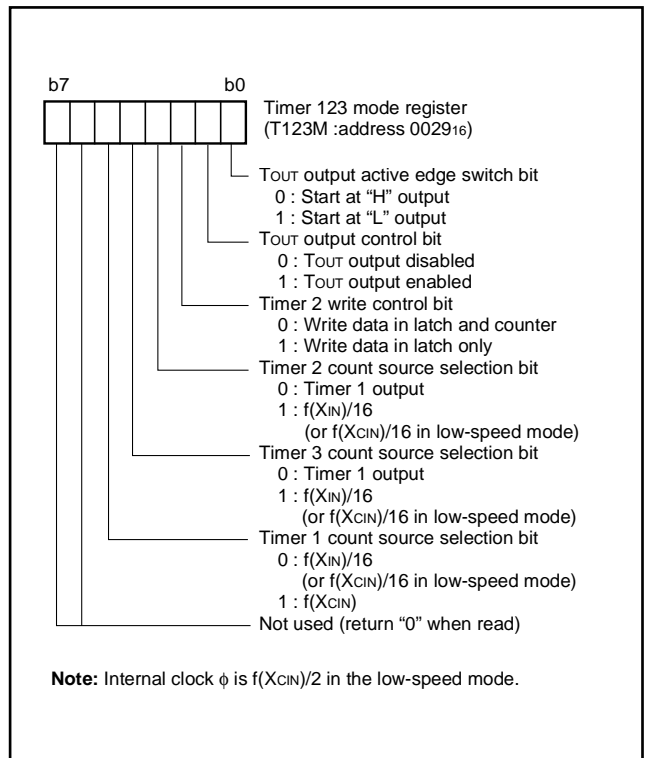

Fig. 24 Structure of timer 123 mode register

SERIAL I/O

Serial I/O can be used as either clock synchronous or asynchronous (UART) serial I/O. A dedicated timer (baud rate generator) is also provided for baud rate generation.

(1) Clock Synchronous Serial I/O Mode

Clock synchronous serial I/O can be selected by setting the mode selection bit of the serial I/O control register to "1".

For clock synchronous serial I/O, the transmitter and the receiver must use the same clock. If an internal clock is used, transfer is started by a write signal to the transmit/receive buffer register.

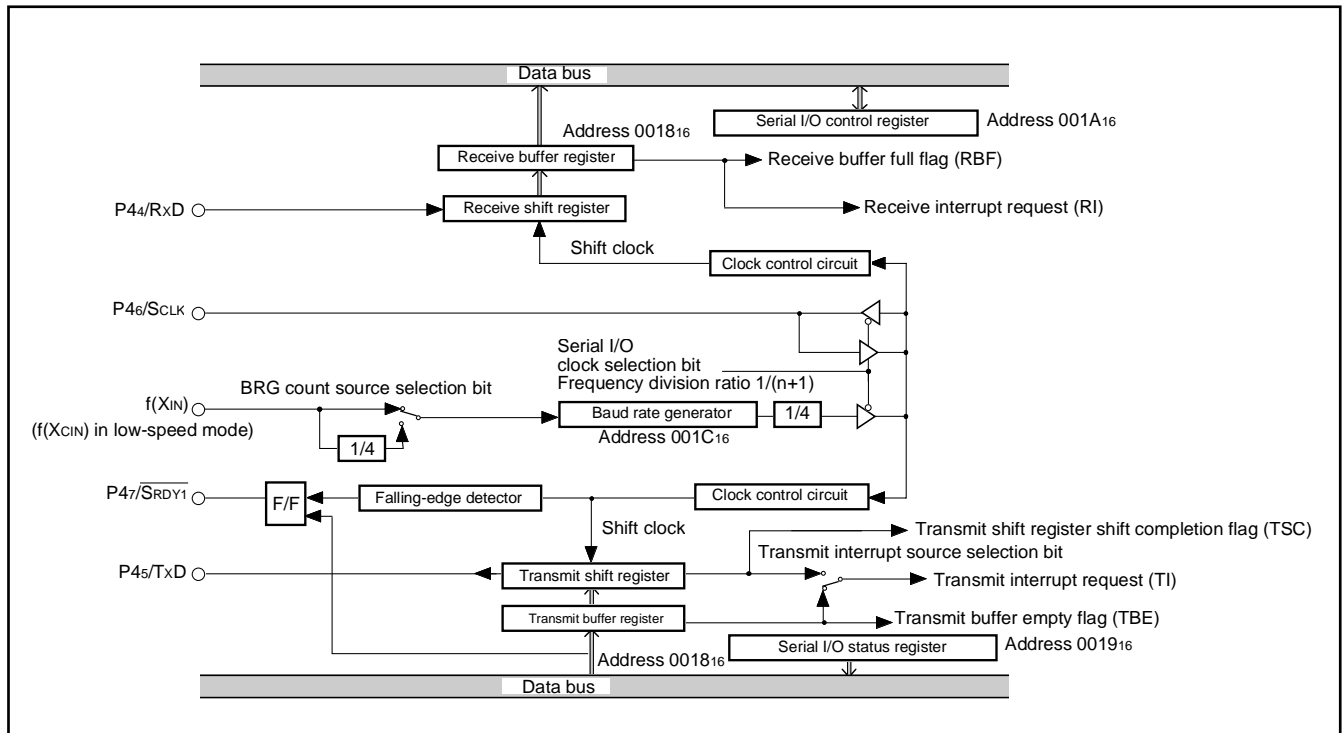

Fig. 25 Block diagram of clock synchronous serial I/O

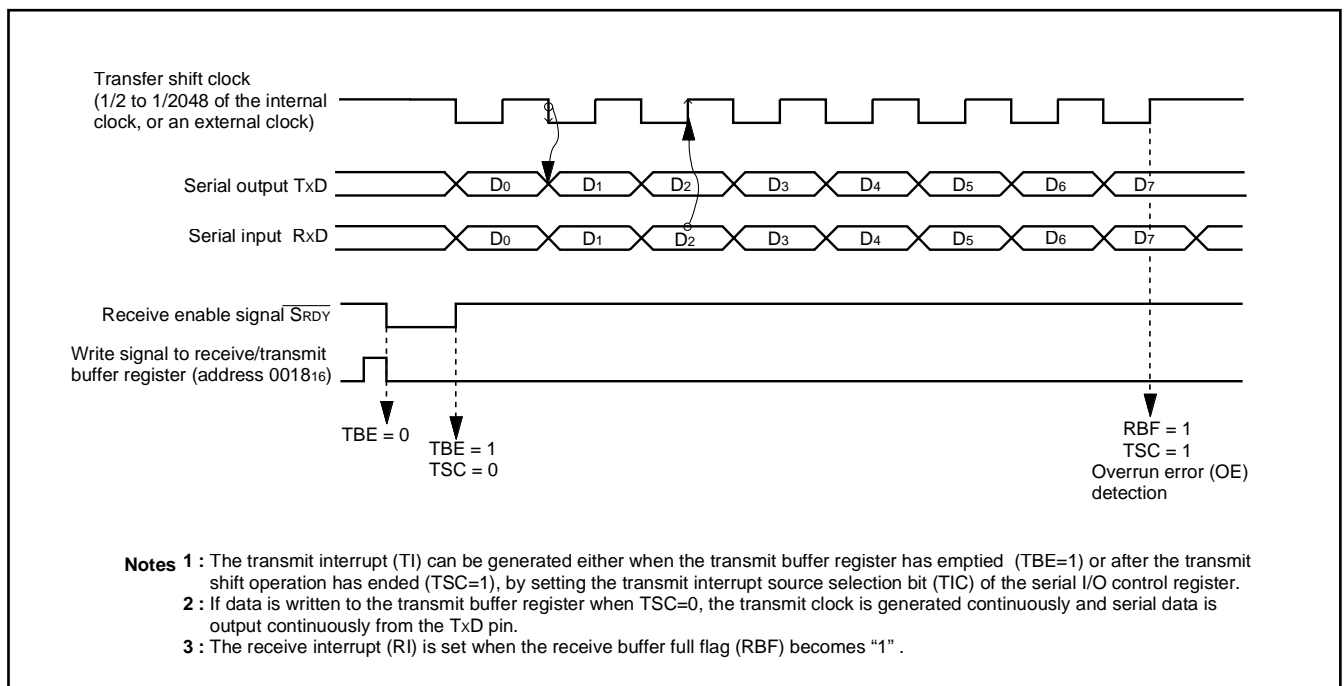

Fig. 26 Operation of clock synchronous serial I/O function

(2) Asynchronous Serial I/O (UART) Mode

Clock asynchronous serial I/O mode (UART) can be selected by clearing the serial I/O mode selection bit of the serial I/O control register to "0".

Eight serial data transfer formats can be selected, and the transfer formats used by a transmitter and receiver must be identical.

The transmit and receive shift registers each have a buffer regis-

ter, but the two buffers have the same address in memory. Since the shift register cannot be written to or read from directly, transmit data is written to the transmit buffer, and receive data is read from the receive buffer.

The transmit buffer can also hold the next data to be transmitted, and the receive buffer register can hold a character while the next character is being received.

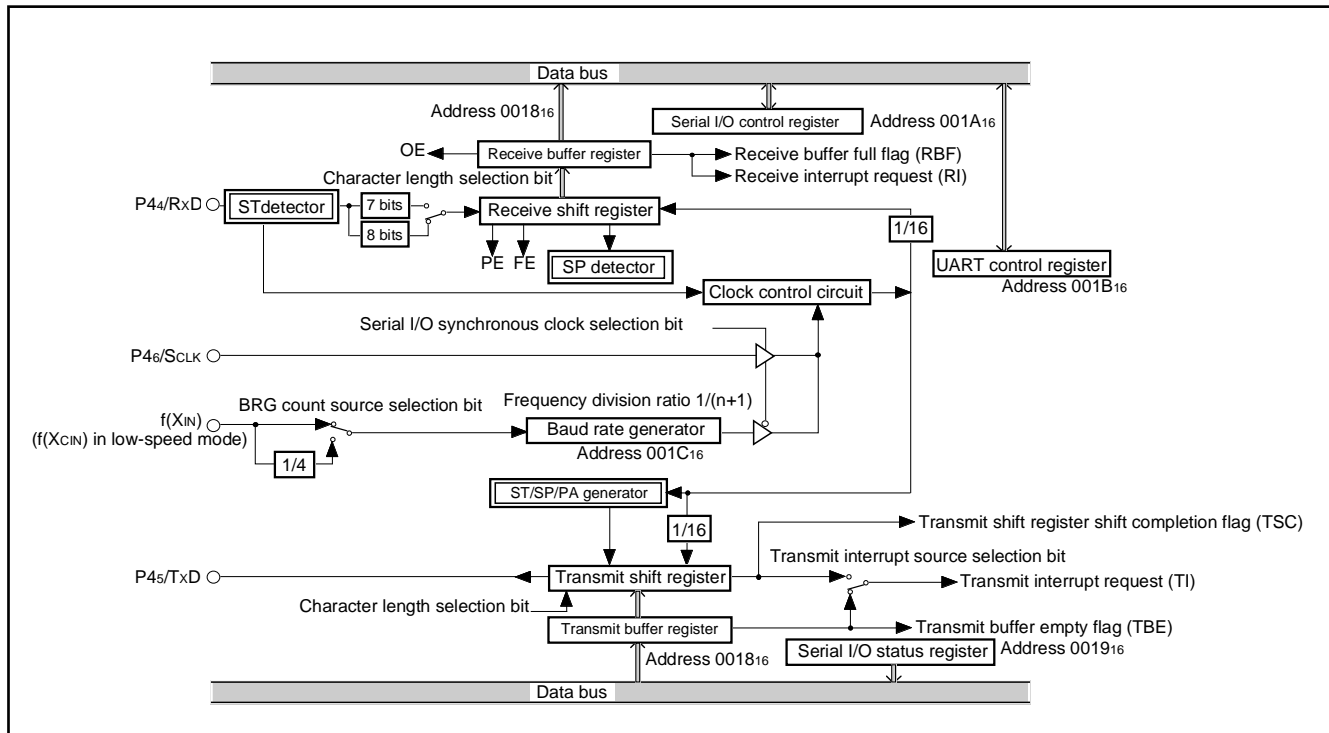

Fig. 27 Block diagram of UART serial I/O

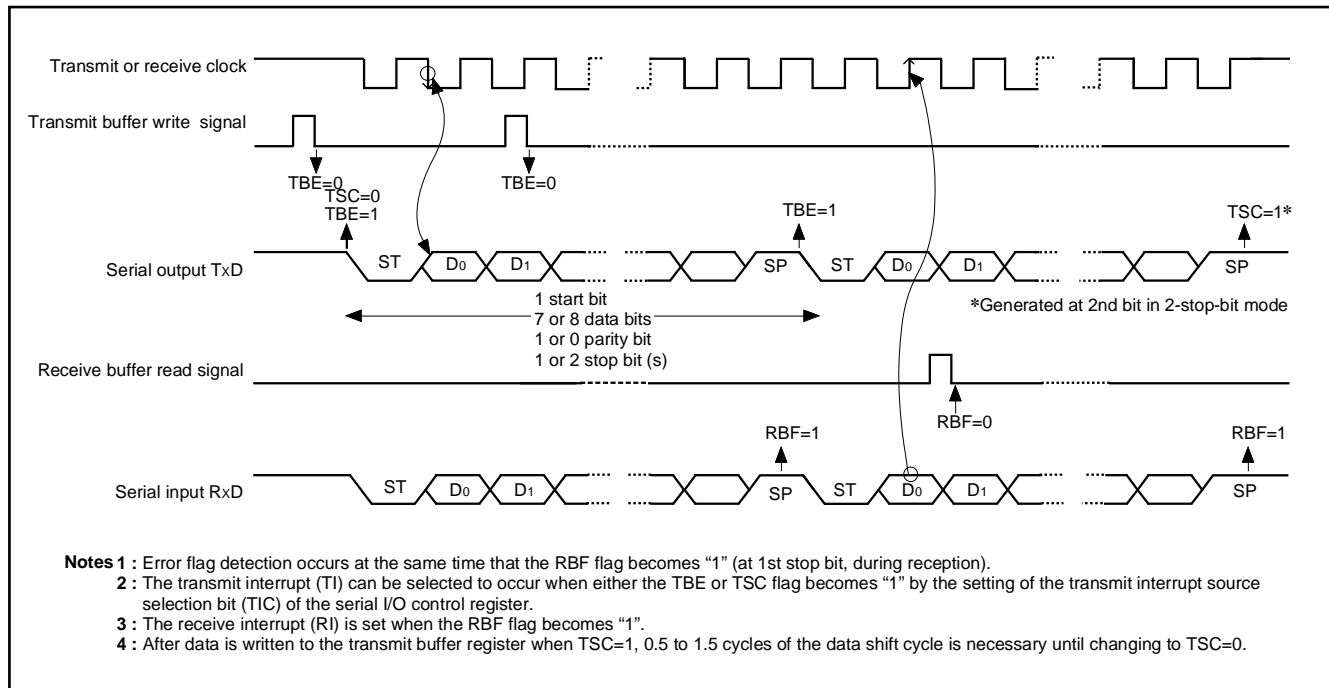

Fig. 28 Operation of UART serial I/O function

[Transmit Buffer/Receive Buffer Register (TB/RB)] 001816

The transmit buffer register and the receive buffer register are located at the same address. The transmit buffer register is write-only and the receive buffer register is read-only. If a character bit length is 7 bits, the MSB of data stored in the receive buffer register is "0".

[Serial I/O Status Register (SIOSTS)] 001916

The read-only serial I/O status register consists of seven flags (bits 0 to 6) which indicate the operating status of the serial I/O function and various errors.

Three of the flags (bits 4 to 6) are valid only in UART mode.

The receive buffer full flag (bit 1) is cleared to "0" when the receive buffer is read.

If there is an error, it is detected at the same time that data is transferred from the receive shift register to the receive buffer register, and the receive buffer full flag is set. A write to the serial I/O status register clears all the error flags OE, PE, FE, and SE. Writing "0" to the serial I/O enable bit (SIOE) also clears all the status flags, including the error flags.

All bits of the serial I/O status register are initialized to "0" at reset, but if the transmit enable bit (bit 4) of the serial I/O control register has been set to "1", the transmit shift register shift completion flag (bit 2) and the transmit buffer empty flag (bit 0) become "1".

[Serial I/O Control Register (SIOCON)] 001A16

The serial I/O control register contains eight control bits for the serial I/O function.

[UART Control Register (UARTCON)] 001B16

The UART control register consists of four control bits (bits 0 to 3) which are valid when asynchronous serial I/O is selected and set the data format of an data transfer. One bit in this register (bit 4) is always valid and sets the output structure of the P45/TxD pin.

[Baud Rate Generator (BRG)] 001C16

The baud rate generator determines the baud rate for serial transfer.

The baud rate generator divides the frequency of the count source by $1/(n + 1)$, where n is the value written to the baud rate generator.

■Notes on serial I/O

When setting the transmit enable bit to "1", the serial I/O transmit interrupt request bit is automatically set to "1". When not requiring the interrupt occurrence synchronized with the transmission enabled, take the following sequence.

- ① Set the serial I/O transmit interrupt enable bit to "0" (disabled).
- ② Set the transmit enable bit to "1".
- ③ Set the serial I/O transmit interrupt request bit to "0" after 1 or more instructions have been executed.
- ④ Set the serial I/O transmit interrupt enable bit to "1" (enabled).

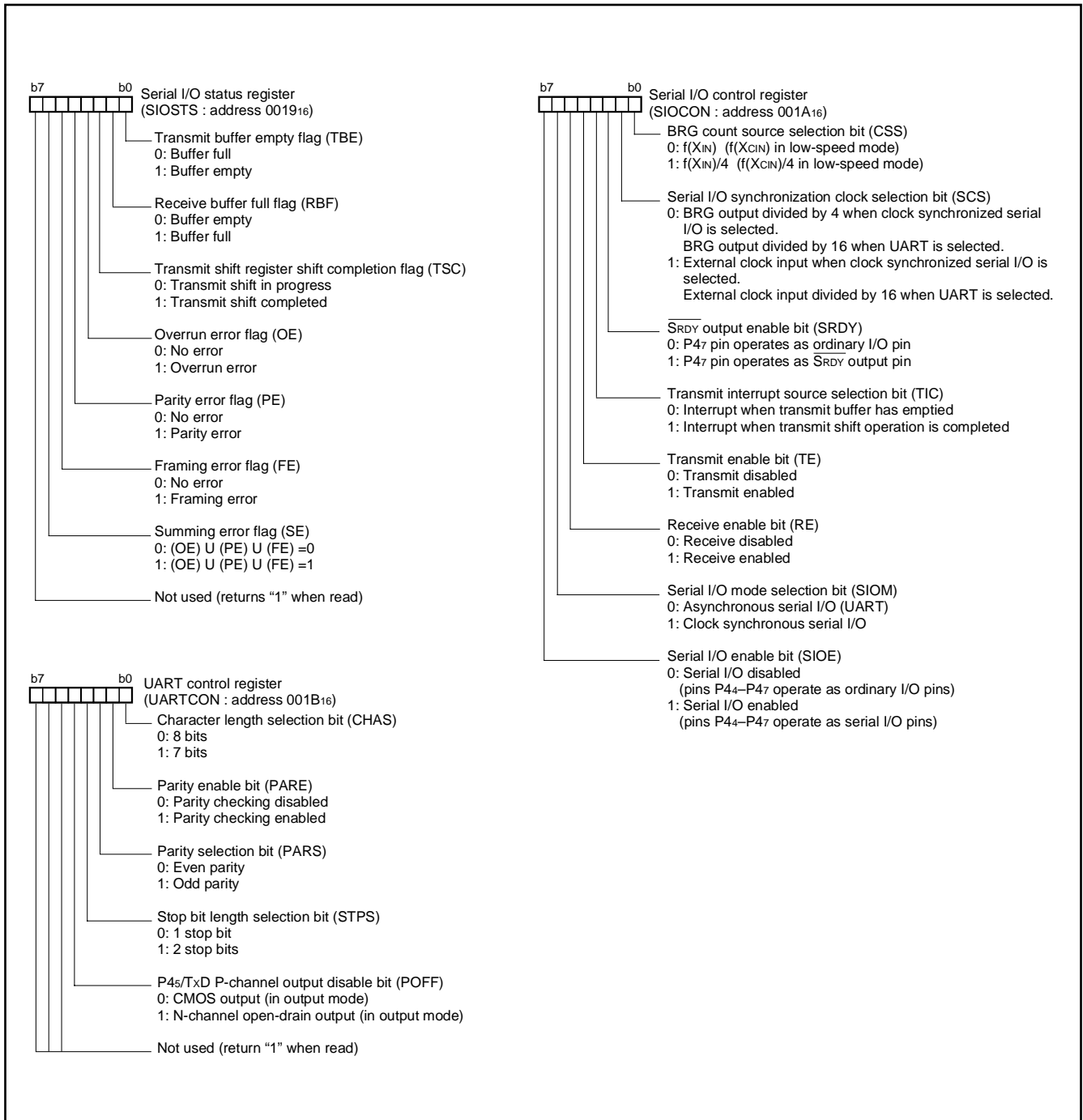

Fig. 29 Structure of serial I/O control registers

A-D CONVERTER

[A-D Conversion Register (AD)] 003516

The A-D conversion register is a read-only register that contains the result of an A-D conversion. When reading this register during an A-D conversion, the previous conversion result is read.

[A-D Control Register (ADCON)] 003416

The A-D control register controls the A-D conversion process. Bits 0 to 2 of this register select specific analog input pins. Bit 3 signals the completion of an A-D conversion. The value of this bit remains at "0" during an A-D conversion, then changes to "1" when the A-D conversion is completed. Writing "0" to this bit starts the A-D conversion. Bit 4 controls the transistor which breaks the through current of the resistor ladder. When bit 5, which is the AD external trigger valid bit, is set to "1", this bit enables A-D conversion even by a falling edge of an ADT input. Set ports which share with ADT pins to input when using an A-D external trigger.

[Comparison Voltage Generator]

The comparison voltage generator divides the voltage between AVSS and VREF by 256, and outputs the divided voltages.

[Channel Selector]

The channel selector selects one of the input ports P67/AN7–P60/AN0, and inputs it to the comparator.

[Comparator and Control Circuit]

The comparator and control circuit compares an analog input voltage with the comparison voltage and stores the result in the A-D conversion register. When an A-D conversion is completed, the control circuit sets the AD conversion completion bit and the AD interrupt request bit to "1".

Note that the comparator is constructed linked to a capacitor, so set f(XIN) to at least 500 kHz during A-D conversion.

Use the clock divided from the main clock XIN as the internal clock ϕ .

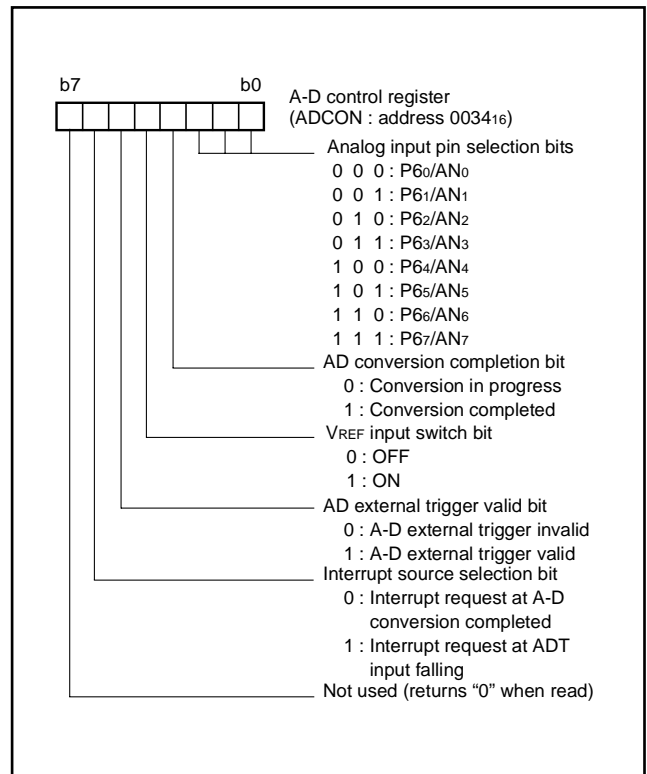

Fig. 30 Structure of A-D control register

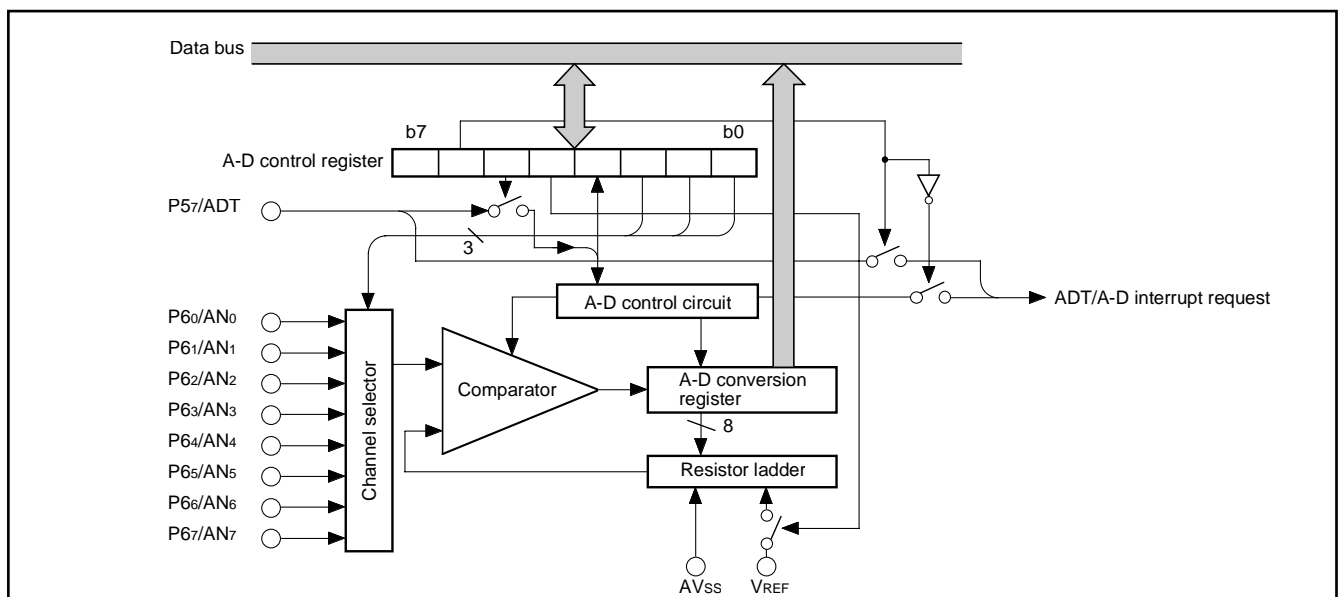

Fig. 31 A-D converter block diagram

LCD DRIVE CONTROL CIRCUIT

The 3822 group has the built-in Liquid Crystal Display (LCD) drive control circuit consisting of the following.

- LCD display RAM
- Segment output enable register
- LCD mode register
- Selector
- Timing controller
- Common driver
- Segment driver
- Bias control circuit

A maximum of 32 segment output pins and 4 common output pins can be used.

Up to 128 pixels can be controlled for LCD display. When the LCD

enable bit is set to "1" after data is set in the LCD mode register, the segment output enable register and the LCD display RAM, the LCD drive control circuit starts reading the display data automatically, performs the bias control and the duty ratio control, and displays the data on the LCD panel.

Table 11 Maximum number of display pixels at each duty ratio

Duty ratio	Maximum number of display pixel
2	64 dots or 8 segment LCD 8 digits
3	96 dots or 8 segment LCD 12 digits
4	128 dots or 8 segment LCD 16 digits

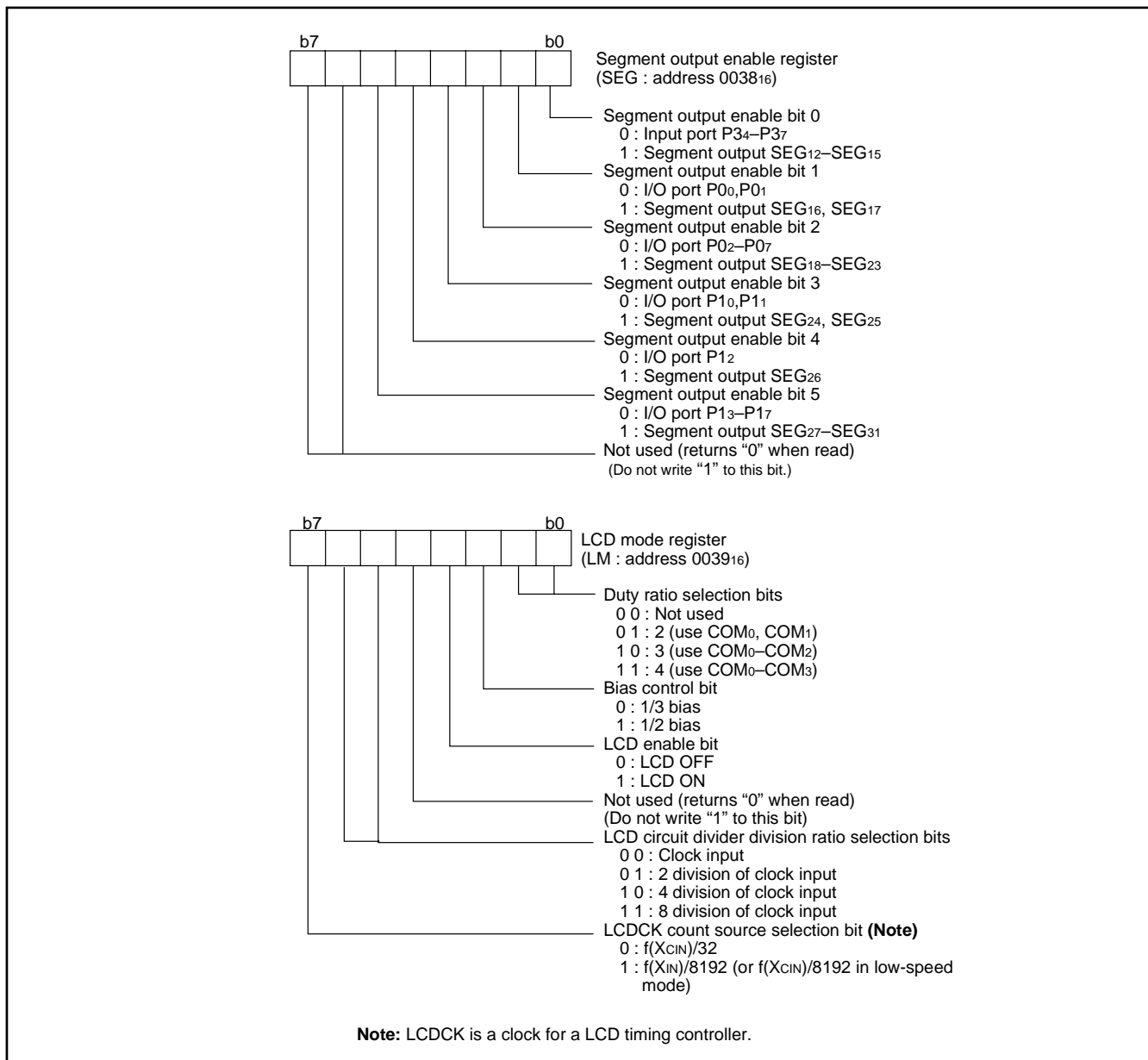

Fig. 32 Structure of segment output enable register and LCD mode register

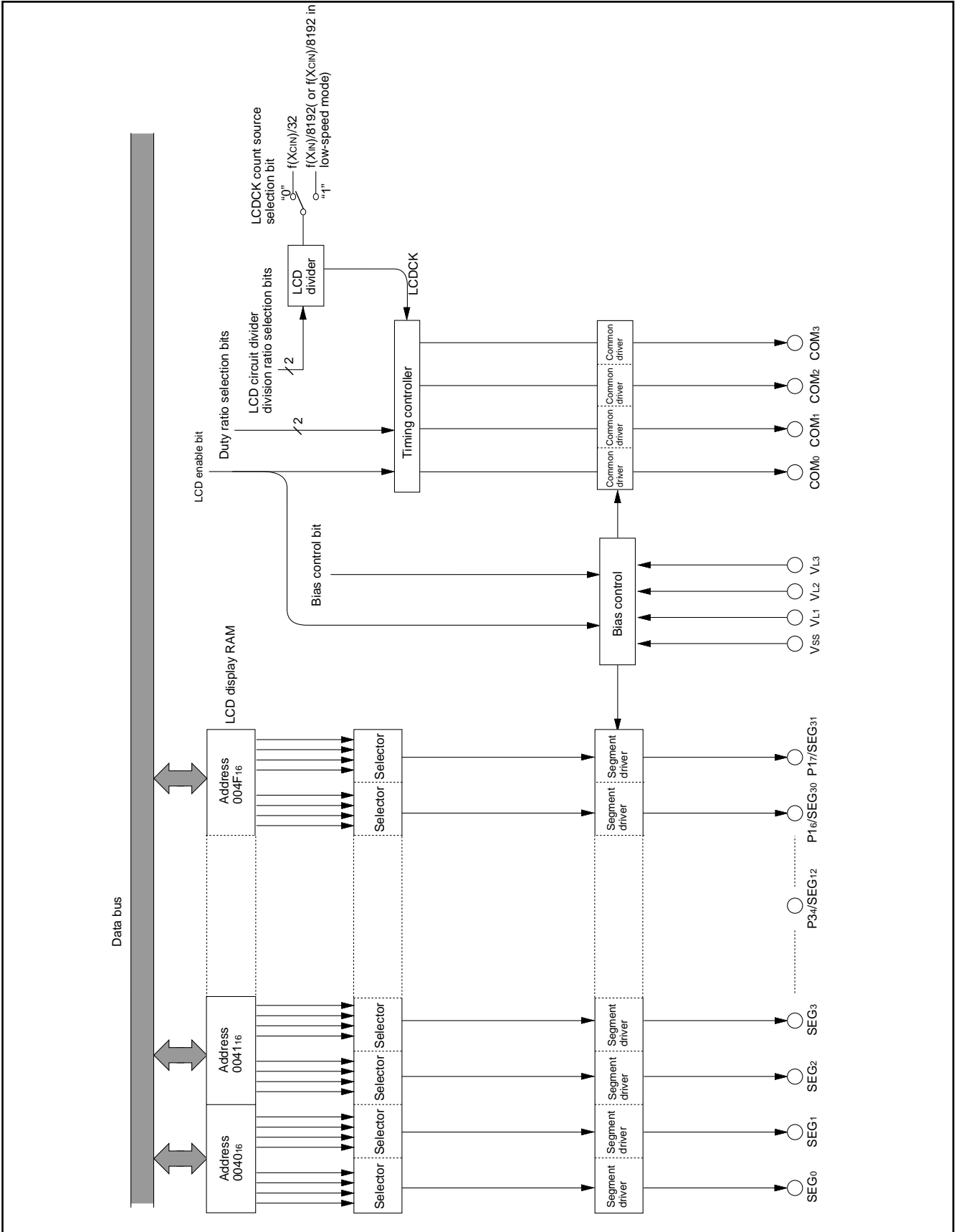

Fig. 33 Block diagram of LCD controller/driver

Bias Control and Applied Voltage to LCD Power Input Pins

To the LCD power input pins (VL1–VL3), apply the voltage shown in Table 12 according to the bias value.

Select a bias value by the bias control bit (bit 2 of the LCD mode register).

Common Pin and Duty Ratio Control

The common pins (COM0–COM3) to be used are determined by duty ratio.

Select duty ratio by the duty ratio selection bits (bits 0 and 1 of the LCD mode register).

Table 12 Bias control and applied voltage to VL1–VL3

Bias value	Voltage value
1/3 bias	VL3=VLCD VL2=2/3 VLCD VL1=1/3 VLCD
1/2 bias	VL3=VLCD VL2=VL1=1/2 VLCD

Note 1: VLCD is the maximum value of supplied voltage for the LCD panel.

Table 13 Duty ratio control and common pins used

Duty ratio	Duty ratio selection bit		Common pins used
	Bit 1	Bit 0	
2	0	1	COM0, COM1 (Note 1)
3	1	0	COM0–COM2 (Note 2)
4	1	1	COM0–COM3

Notes1: COM2 and COM3 are open.
2: COM3 is open.

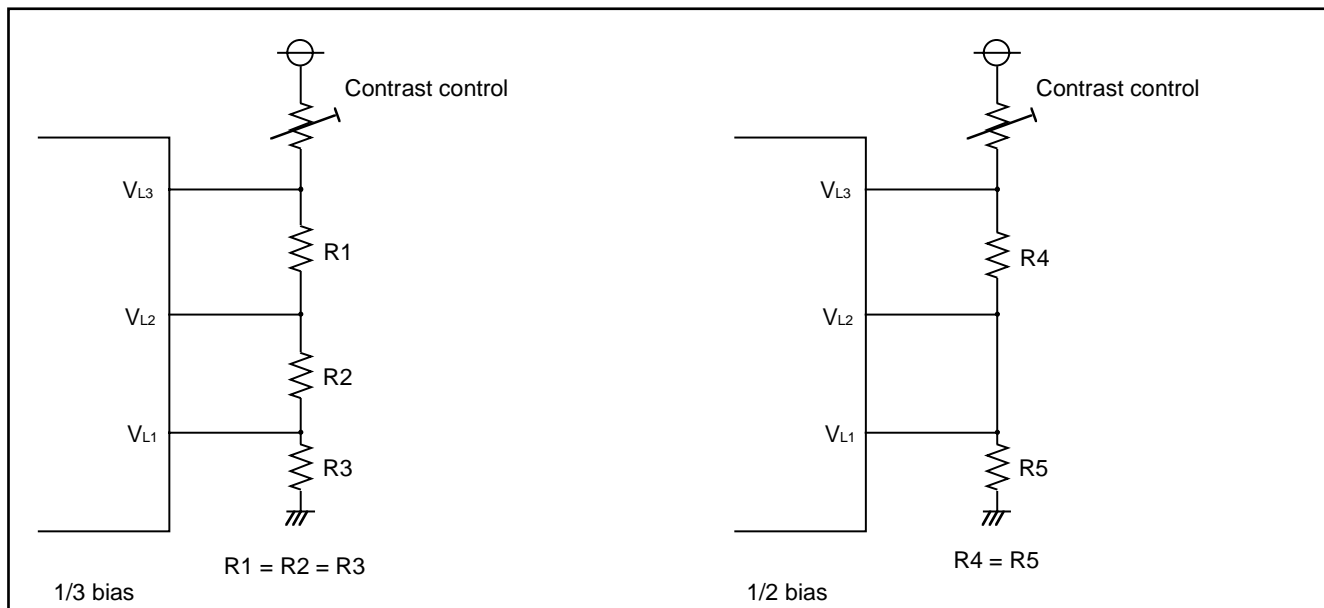

Fig. 34 Example of circuit at each bias

LCD Display RAM

Address 0040₁₆ to 004F₁₆ is the designated RAM for the LCD display. When “1” are written to these addresses, the corresponding segments of the LCD display panel are turned on.

LCD Drive Timing

The LCDCK timing frequency (LCD drive timing) is generated internally and the frame frequency can be determined with the following equation;

$$f(\text{LCDCK}) = \frac{\text{(frequency of count source for LCDCK)}}{\text{(divider division ratio for LCD)}}$$

$$\text{Frame frequency} = \frac{f(\text{LCDCK})}{\text{(duty ratio)}}$$

Bit Address	7	6	5	4	3	2	1	0
0040 ₁₆	SEG1				SEG0			
0041 ₁₆	SEG3				SEG2			
0042 ₁₆	SEG5				SEG4			
0043 ₁₆	SEG7				SEG6			
0044 ₁₆	SEG9				SEG8			
0045 ₁₆	SEG11				SEG10			
0046 ₁₆	SEG13				SEG12			
0047 ₁₆	SEG15				SEG14			
0048 ₁₆	SEG17				SEG16			
0049 ₁₆	SEG19				SEG18			
004A ₁₆	SEG21				SEG20			
004B ₁₆	SEG23				SEG22			
004C ₁₆	SEG25				SEG24			
004D ₁₆	SEG27				SEG26			
004E ₁₆	SEG29				SEG28			
004F ₁₆	SEG31				SEG30			
	COM3	COM2	COM1	COM0	COM3	COM2	COM1	COM0

Fig. 35 LCD display RAM map

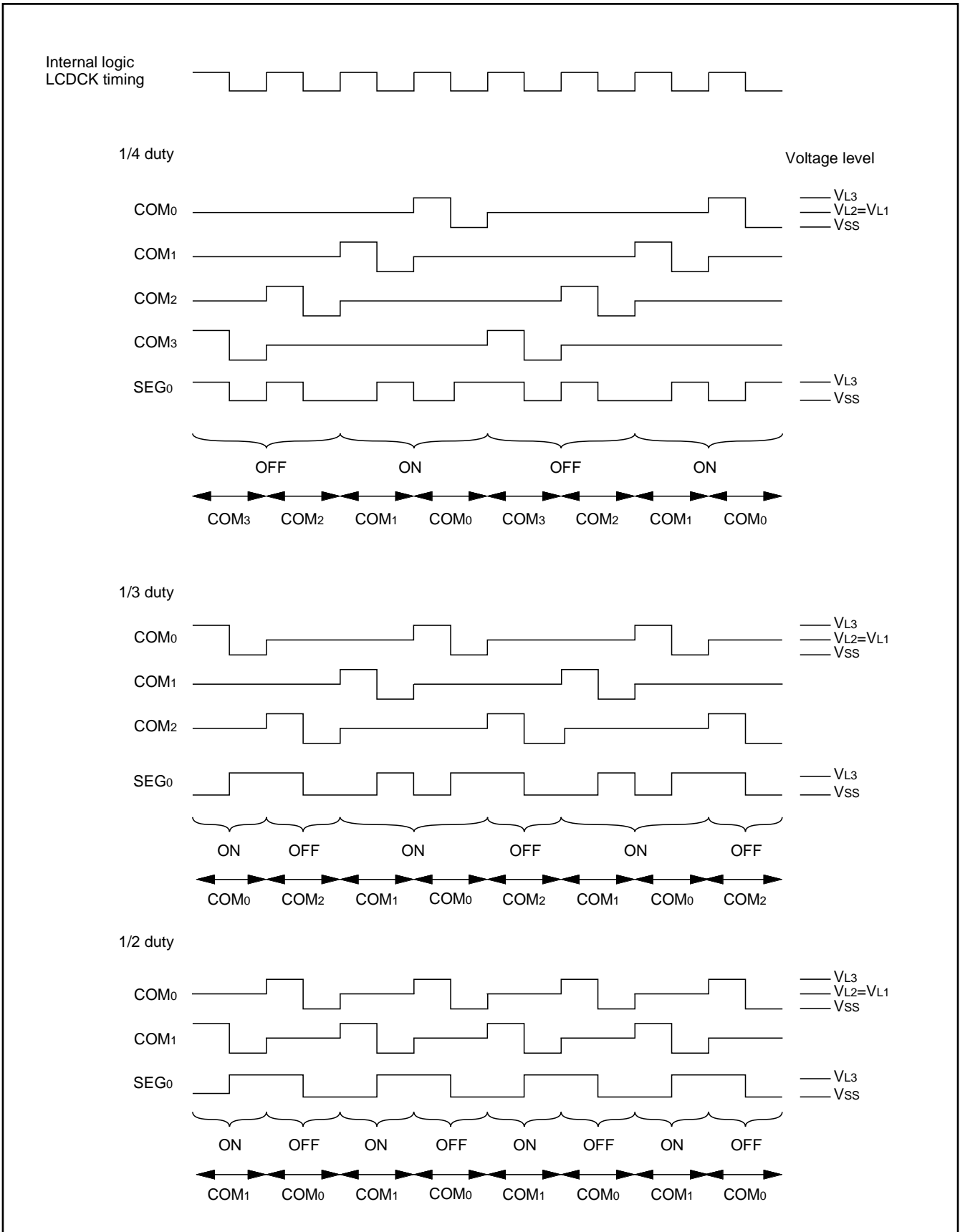

Fig. 36 LCD drive waveform (1/2 bias)

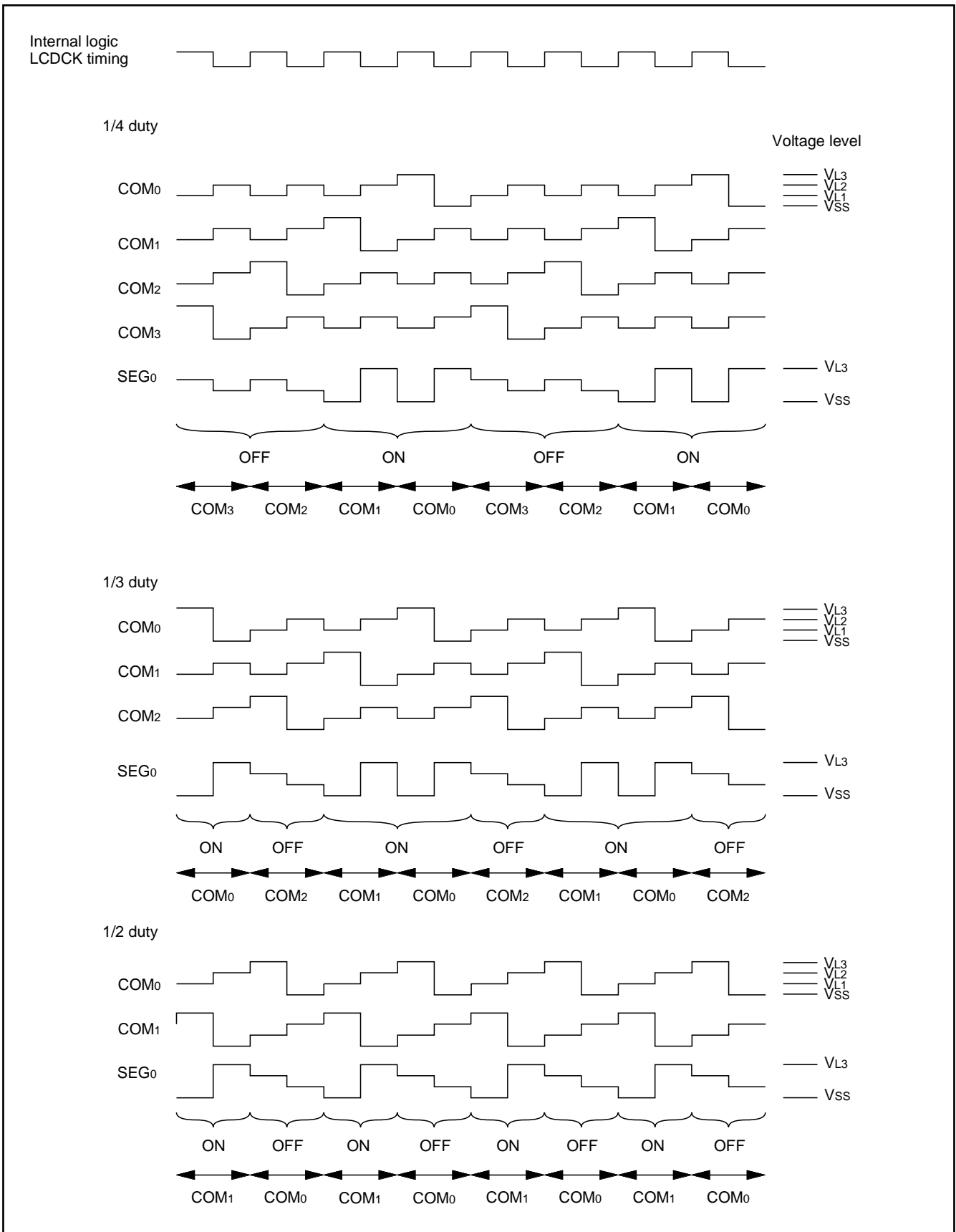

Fig. 37 LCD drive waveform (1/3 bias)

ϕ CLOCK SYSTEM OUTPUT FUNCTION

The internal system clock ϕ can be output from port P4₁ by setting the ϕ output control register. Set bit 1 of the port P4 direction register to "1" when outputting ϕ clock.

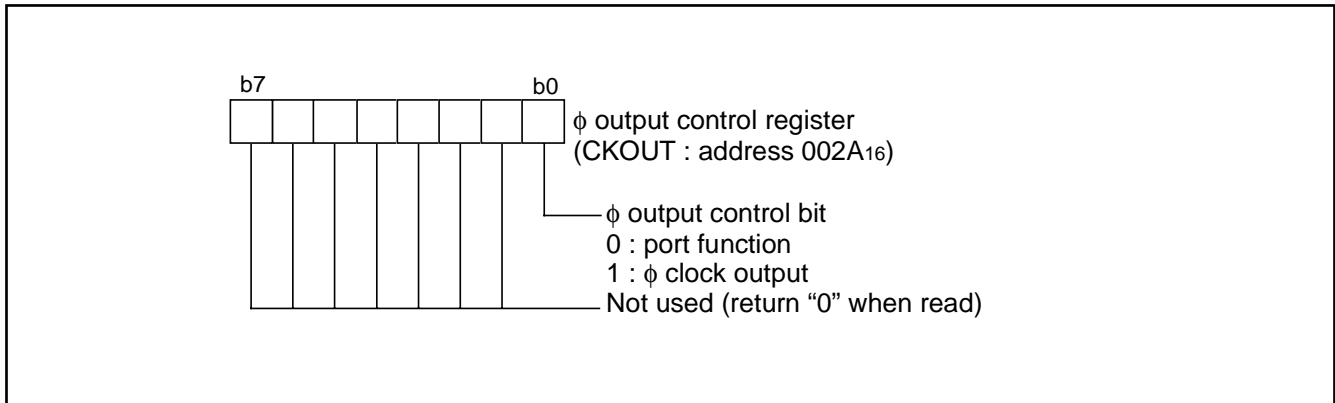

Fig. 38 Structure of ϕ output control register

RESET CIRCUIT

To reset the microcomputer, $\overline{\text{RESET}}$ pin should be held at an "L" level for 2 μs or more. Then the $\overline{\text{RESET}}$ pin is returned to an "H" level (the power source voltage should be between $V_{CC}(\text{min.})$ and 5.5 V, and the quartz-crystal oscillator should be stable), reset is released. After the reset is completed, the program starts from the address contained in address FFFD_{16} (high-order byte) and address FFFC_{16} (low-order byte). Make sure that the reset input voltage meets $V_{IL \text{ spec.}}$ when a power source voltage passes $V_{CC}(\text{min.})$.

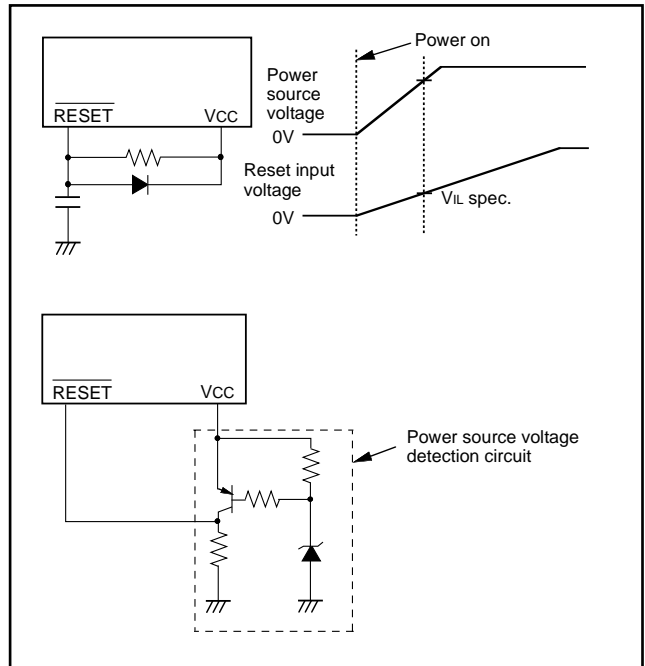

Fig. 39 Reset Circuit Example

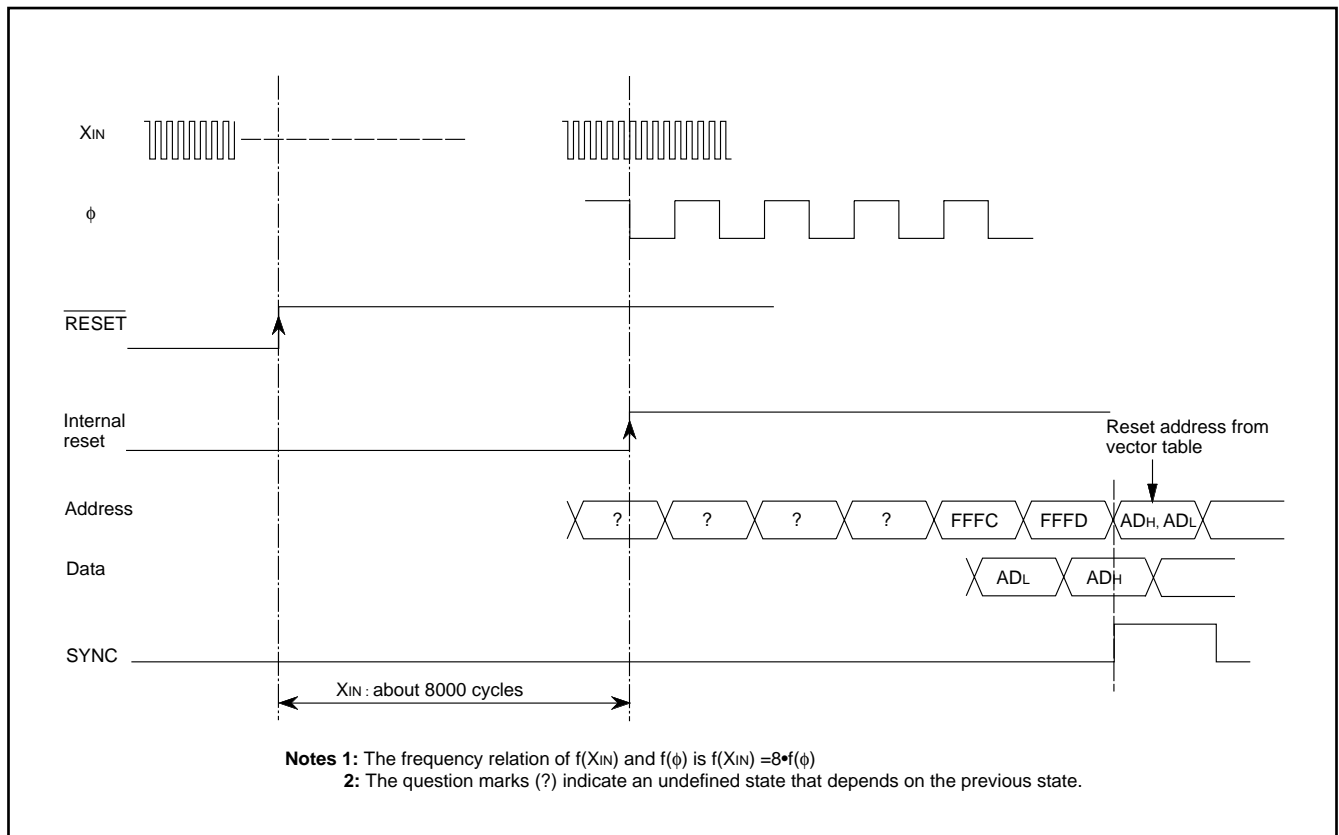

Fig. 40 Reset Sequence

	Address	Register Contents
(1) Port P0 direction register	0001 ₁₆	00 ₁₆
(2) Port P1 direction register	0003 ₁₆	00 ₁₆
(3) Port P2 direction register	0005 ₁₆	00 ₁₆
(4) Port P4 direction register	0009 ₁₆	00 ₁₆
(5) Port P5 direction register	000B ₁₆	00 ₁₆
(6) Port P6 direction register	000D ₁₆	00 ₁₆
(7) Port P7 direction register	000F ₁₆	00 ₁₆
(8) PULL register A	0016 ₁₆	0 0 0 0 1 0 1 1
(9) PULL register B	0017 ₁₆	00 ₁₆
(10) Serial I/O status register	0019 ₁₆	1 0 0 0 0 0 0 0
(11) Serial I/O control register	001A ₁₆	00 ₁₆
(12) UART control register	001B ₁₆	1 1 1 0 0 0 0 0
(13) Timer X(Low)	0020 ₁₆	FF ₁₆
(14) Timer X(High)	0021 ₁₆	FF ₁₆
(15) Timer Y(Low)	0022 ₁₆	FF ₁₆
(16) Timer Y(High)	0023 ₁₆	FF ₁₆
(17) Timer 1	0024 ₁₆	FF ₁₆
(18) Timer 2	0025 ₁₆	01 ₁₆
(19) Timer 3	0026 ₁₆	FF ₁₆
(20) Timer X mode register	0027 ₁₆	00 ₁₆
(21) Timer Y mode register	0028 ₁₆	00 ₁₆
(22) Timer 123 mode register	0029 ₁₆	00 ₁₆
(23) φ output control register	002A ₁₆	00 ₁₆
(24) A-D control register	0034 ₁₆	0 0 0 0 1 0 0 0
(25) Segment output enable register	0038 ₁₆	00 ₁₆
(26) LCD mode register	0039 ₁₆	00 ₁₆
(27) Interrupt edge selection register	003A ₁₆	00 ₁₆
(28) CPU mode register	003B ₁₆	0 1 0 0 1 0 0 0
(29) Interrupt request register 1	003C ₁₆	00 ₁₆
(30) Interrupt request register 2	003D ₁₆	00 ₁₆
(31) Interrupt control register 1	003E ₁₆	00 ₁₆
(32) Interrupt control register 2	003F ₁₆	00 ₁₆
(33) Processor status register	(PS)	X X X X X 1 X X
(34) Program counter	(PCH)	Contents of address FFFD ₁₆
	(PCL)	Contents of address FFFC ₁₆

Note: The contents of all other registers and RAM are undefined after reset, so they must be initialized by software.
X: undefined

Fig. 41 Initial status of microcomputer after reset

CLOCK GENERATING CIRCUIT

The 3822 group has two built-in oscillation circuits. An oscillation circuit can be formed by connecting a resonator between XIN and XOUT (XCIN and XCOUT). Use the circuit constants in accordance with the resonator manufacturer's recommended values. No external resistor is needed between XIN and XOUT since a feed-back resistor exists on-chip. However, an external feed-back resistor is needed between XCIN and XCOUT.

To supply a clock signal externally, input it to the XIN pin and make the XOUT pin open. The sub-clock XCIN-XCOUT oscillation circuit cannot directly input clocks that are externally generated. Accordingly, be sure to cause an external resonator to oscillate.

Immediately after poweron, only the XIN oscillation circuit starts oscillating, and XCIN and XCOUT pins function as I/O ports.

Frequency Control

(1) Middle-speed Mode

The internal clock ϕ is the frequency of XIN divided by 8. After reset, this mode is selected.

(2) High-speed Mode

The internal clock ϕ is half the frequency of XIN.

(3) Low-speed Mode

- The internal clock ϕ is half the frequency of XCIN.
 - A low-power consumption operation can be realized by stopping the main clock XIN in this mode. To stop the main clock, set bit 5 of the CPU mode register to "1".
- When the main clock XIN is restarted, set enough time for oscillation to stabilize by programming.

Note: If you switch the mode between middle/high-speed and low-speed, stabilize both XIN and XCIN oscillations. The sufficient time is required for the sub-clock to stabilize, especially immediately after poweron and at returning from stop mode. When switching the mode between middle/high-speed and low-speed, set the frequency on condition that $f(XIN) > 3f(XCIN)$.

Oscillation Control

(1) Stop Mode

If the STP instruction is executed, the internal clock ϕ stops at an "H" level, and XIN and XCIN oscillators stop. Timer 1 is set to "FF16" and timer 2 is set to "0116".

Either XIN or XCIN divided by 16 is input to timer 1 as count source, and the output of timer 1 is connected to timer 2. The bits of the timer 123 mode register except bit 4 are cleared to "0". Set the timer 1 and timer 2 interrupt enable bits to disabled ("0") before executing the STP instruction. Oscillator restarts at reset or when an external interrupt is received, but the internal clock ϕ is not supplied to the CPU until timer 2 underflows. This allows timer for the clock circuit oscillation to stabilize.

(2) Wait Mode

If the WIT instruction is executed, the internal clock ϕ stops at an "H" level. The states of XIN and XCIN are the same as the state before the executing the WIT instruction. The internal clock restarts at reset or when an interrupt is received. Since the oscillator does not stop, normal operation can be started immediately after the clock is restarted.

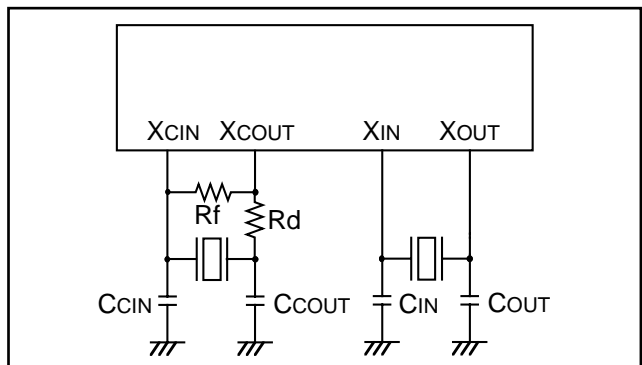

Fig. 42 Ceramic resonator circuit

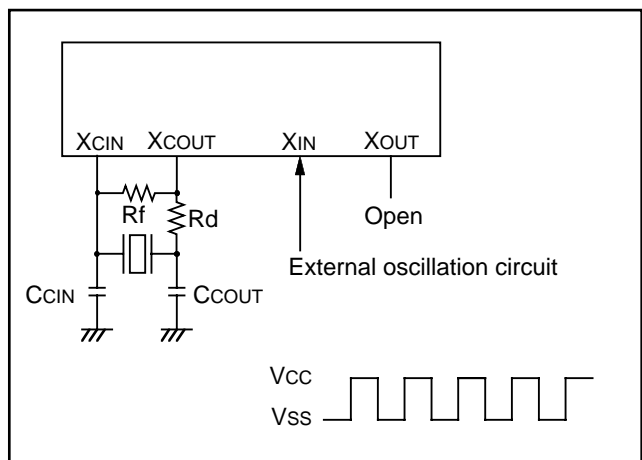

Fig. 43 External clock input circuit

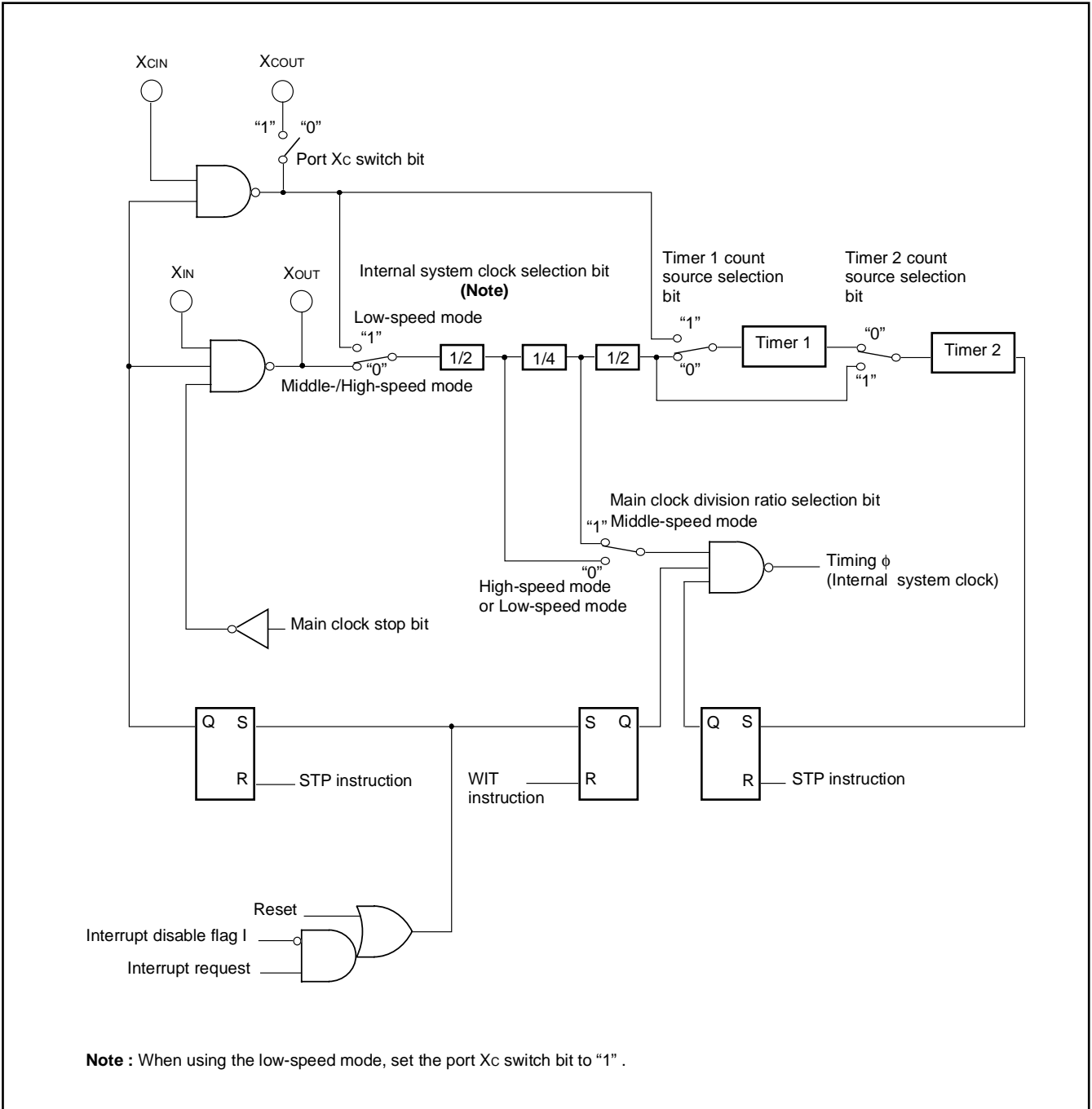

Fig.44 Clock generating circuit block diagram

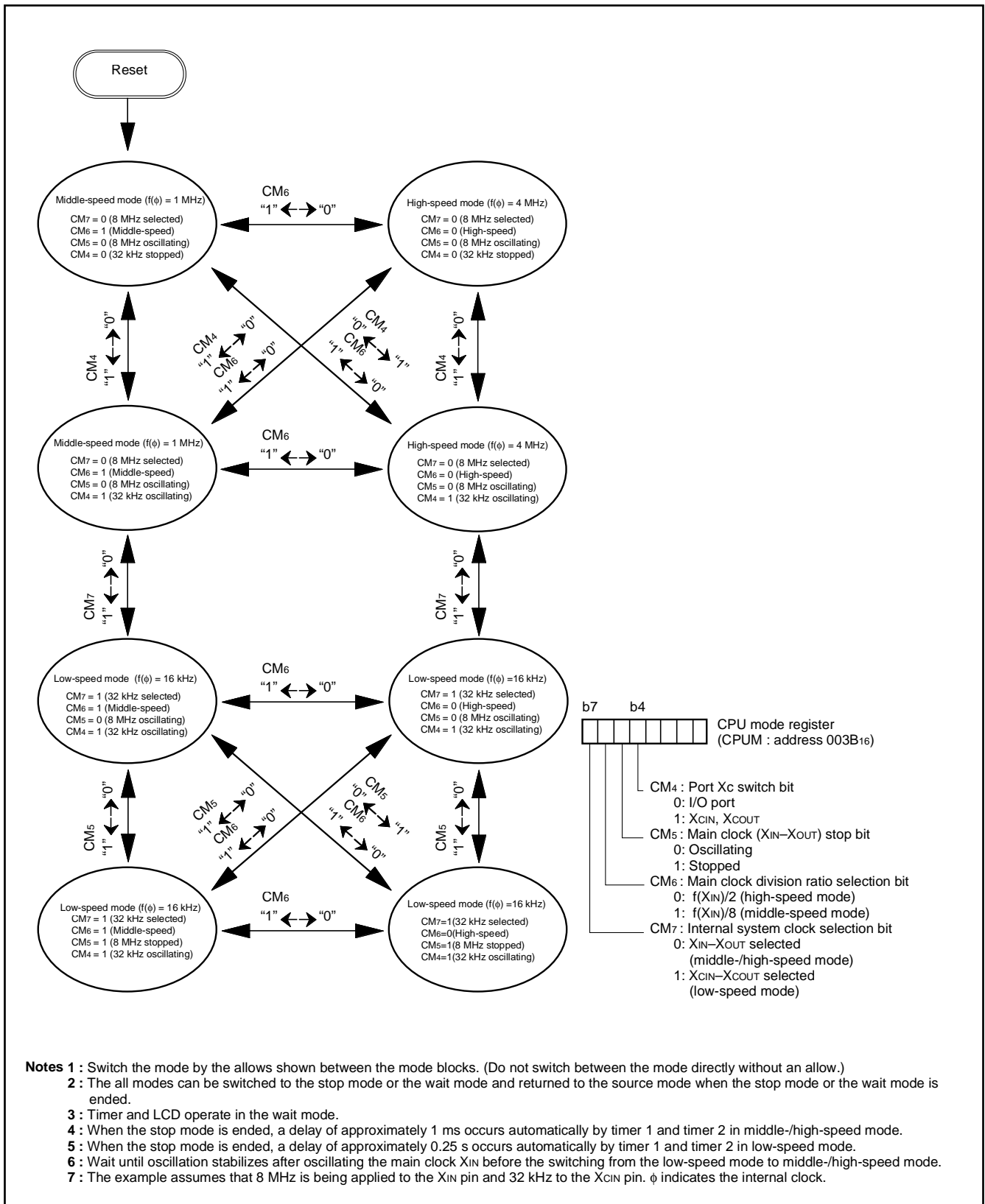

Fig. 45 State transitions of system clock

NOTES ON PROGRAMMING

Processor Status Register

The contents of the processor status register (PS) after a reset are undefined, except for the interrupt disable flag (I) which is "1". After a reset, initialize flags which affect program execution.

In particular, it is essential to initialize the index X mode (T) and the decimal mode (D) flags because of their effect on calculations.

Interrupt

The contents of the interrupt request bits do not change immediately after they have been written. After writing to an interrupt request register, execute at least one instruction before performing a BBC or BBS instruction.

Decimal Calculations

- To calculate in decimal notation, set the decimal mode flag (D) to "1", then execute an ADC or SBC instruction. After executing an ADC or SBC instruction, execute at least one instruction before executing a SEC, CLC, or CLD instruction.
- In decimal mode, the values of the negative (N), overflow (V), and zero (Z) flags are invalid.

Timers

If a value n (between 0 and 255) is written to a timer latch, the frequency division ratio is $1/(n + 1)$.

Multiplication and Division Instructions

The index mode (T) and the decimal mode (D) flags do not affect the MUL and DIV instruction.

The execution of these instructions does not change the contents of the processor status register.

Ports

The contents of the port direction registers cannot be read.

The following cannot be used:

- The data transfer instruction (LDA, etc.)
- The operation instruction when the index X mode flag (T) is "1"
- The addressing mode which uses the value of a direction register as an index
- The bit-test instruction (BBC or BBS, etc.) to a direction register
- The read-modify-write instruction (ROR, CLB, or SEB, etc.) to a direction register

Use instructions such as LDM and STA, etc., to set the port direction registers.

Serial I/O

In clock synchronous serial I/O, if the receive side is using an external clock and it is to output the $\overline{\text{SRDY}}$ signal, set the transmit enable bit, the receive enable bit, and the $\overline{\text{SRDY}}$ output enable bit to "1".

Serial I/O continues to output the final bit from the TXD pin after transmission is completed.

A-D Converter

The comparator uses internal capacitors whose charge will be lost if the clock frequency is too low.

Make sure that $f(\text{XIN})$ is at least 500 kHz during an A-D conversion.

Do not execute the STP or WIT instruction during an A-D conversion.

Instruction Execution Time

The instruction execution time is obtained by multiplying the frequency of the internal clock ϕ by the number of cycles needed to execute an instruction.

The number of cycles required to execute an instruction is shown in the list of machine instructions.

The frequency of the internal clock ϕ is half of the XIN frequency.

DATA REQUIRED FOR MASK ORDERS

The following are necessary when ordering a mask ROM production:

- 1.Mask ROM Order Confirmation Form*
- 2.Mark Specification Form*
- 3.Data to be written to ROM, in EPROM form (three identical copies) or one floppy disk

*For the mask ROM confirmation and the mark specifications, refer to the "Mitsubishi MCU Technical Information" Homepage (<http://www.infocom.mesc.co.jp/>).

ROM PROGRAMMING METHOD

The built-in PROM of the blank One Time PROM version and built-in EPROM version can be read or programmed with a general-purpose PROM programmer using a special programming adapter. Set the address of PROM programmer in the user ROM area.

Table 14 Programming adapter

Package	Name of Programming Adapter
80P6N-A	PCA4738F-80A
80P6S-A	PCA4738G-80A
80P6Q-A	PCA4738H-80A
80D0	PCA4738L-80A

The PROM of the blank One Time PROM version is not tested or screened in the assembly process and following processes. To ensure proper operation after programming, the procedure shown in Figure 46 is recommended to verify programming.

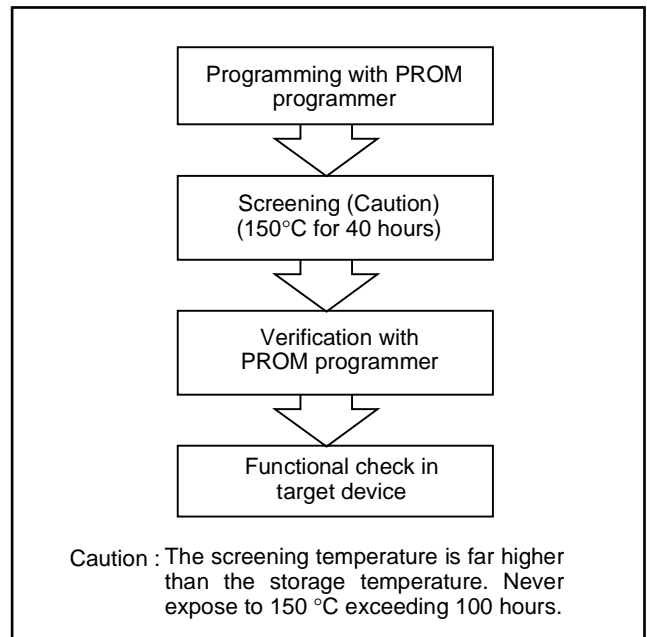

Fig. 46 Programming and testing of One Time PROM version

Table 15 Absolute maximum ratings (Standard, One Time PROM version)

Symbol	Parameter	Conditions	Ratings	Unit	
VCC	Power source voltage	All voltages are based on VSS. Output transistors are cut off.	-0.3 to 7.0	V	
VI	Input voltage P00-P07, P10-P17, P20-P27, P34-P37, P40-P47, P50-P57, P60-P67, P70, P71		-0.3 to VCC +0.3	V	
VI	Input voltage VL1		-0.3 to VL2	V	
VI	Input voltage VL2		VL1 to VL3	V	
VI	Input voltage VL3		VL2 to VCC +0.3	V	
VI	Input voltage RESET, XIN		-0.3 to VCC +0.3	V	
VO	Output voltage P00-P07, P10-P17		At output port	-0.3 to VCC +0.3	V
			At segment output	-0.3 to VL3+0.3	V
VO	Output voltage P34-P37	At segment output	-0.3 to VL3+0.3	V	
VO	Output voltage P20-P27, P41-P47, P50-P57, P60-P67, P70, P71		-0.3 to VCC +0.3	V	
VO	Output voltage SEG0-SEG11		-0.3 to VL3+0.3	V	
VO	Output voltage XOUT		-0.3 to VCC +0.3	V	
Pd	Power dissipation	Ta = 25°C	300	mW	
Topr	Operating temperature		-20 to 85	°C	
Tstg	Storage temperature		-40 to 125	°C	

Table 16 Recommended operating conditions (Standard, One Time PROM version)

(VCC = 2.5 to 5.5 V, Ta = -20 to 85 °C, unless otherwise noted)

Symbol	Parameter		Limits			Unit
			Min.	Typ.	Max.	
VCC	Power source voltage	High-speed mode f(XIN) = 8 MHz	4.0	5.0	5.5	V
		Middle-speed mode f(XIN) = 8 MHz	2.5	5.0	5.5	
		Low-speed mode	2.5	5.0	5.5	
VSS	Power source voltage		0		V	
VREF	A-D conversion reference voltage		2.0		VCC	V
AVSS	Analog power source voltage			0		V
VIA	Analog input voltage AN0-AN7		AVSS		VCC	V
VIH	"H" input voltage P00-P07, P10-P17, P34-P37, P40, P41, P45, P47, P52, P53, P56, P60-P67, P70, P71 (CM4= 0)		0.7VCC		VCC	V
VIH	"H" input voltage P20-P27, P42-P44, P46, P50, P51, P54, P55, P57		0.8VCC		VCC	V
VIH	"H" input voltage RESET		0.8VCC		VCC	V
VIH	"H" input voltage XIN		0.8VCC		VCC	V
VIL	"L" input voltage P00-P07, P10-P17, P34-P37, P40, P41, P45, P47, P52, P53, P56, P60-P67, P70, P71 (CM4= 0)		0		0.3 VCC	V
VIL	"L" input voltage P20-P27, P42-P44, P46, P50, P51, P54, P55, P57		0		0.2 VCC	V
VIL	"L" input voltage RESET		0		0.2 VCC	V
VIL	"L" input voltage XIN		0		0.2 VCC	V

Table 17 Recommended operating conditions (Standard, One Time PROM version)

(VCC = 2.5 to 5.5 V, Ta = -20 to 85 °C, unless otherwise noted)

Symbol	Parameter	Limits			Unit
		Min.	Typ.	Max.	
$\Sigma I_{OH(peak)}$	"H" total peak output current P00-P07, P10-P17, P20-P27 (Note 1)			-40	mA
$\Sigma I_{OH(peak)}$	"H" total peak output current P41-P47, P50-P57, P60-P67, P70, P71 (Note 1)			-40	mA
$\Sigma I_{OL(peak)}$	"L" total peak output current P00-P07, P10-P17, P20-P27 (Note 1)			40	mA
$\Sigma I_{OL(peak)}$	"L" total peak output current P41-P47, P50-P57, P60-P67, P70, P71 (Note 1)			40	mA
$\Sigma I_{OH(avg)}$	"H" total average output current P00-P07, P10-P17, P20-P27 (Note 1)			-20	mA
$\Sigma I_{OH(avg)}$	"H" total average output current P41-P47, P50-P57, P60-P67, P70, P71 (Note 1)			-20	mA
$\Sigma I_{OL(avg)}$	"L" total average output current P00-P07, P10-P17, P20-P27 (Note 1)			20	mA
$\Sigma I_{OL(avg)}$	"L" total average output current P41-P47, P50-P57, P60-P67, P70, P71 (Note 1)			20	mA
$I_{OH(peak)}$	"H" peak output current P00-P07, P10-P17 (Note 2)			-2	mA
$I_{OH(peak)}$	"H" peak output current P20-P27, P41-P47, P50-P57, P60-P67, P70, P71 (Note 2)			-5	mA
$I_{OL(peak)}$	"L" peak output current P00-P07, P10-P17 (Note 2)			5	mA
$I_{OL(peak)}$	"L" peak output current P20-P27, P41-P47, P50-P57, P60-P67, P70, P71 (Note 2)			10	mA
$I_{OH(avg)}$	"H" average output current P00-P07, P10-P17 (Note 3)			-1.0	mA
$I_{OH(avg)}$	"H" average output current P20-P27, P41-P47, P50-P57, P60-P67, P70, P71 (Note 3)			-2.5	mA
$I_{OL(avg)}$	"L" average output current P00-P07, P10-P17 (Note 3)			2.5	mA
$I_{OL(avg)}$	"L" average output current P20-P27, P41-P47, P50-P57, P60-P67, P70, P71 (Note 3)			5.0	mA
$f(CNTR0)$ $f(CNTR1)$	Input frequency for timers X and Y (duty cycle 50%)	(4.0 V ≤ VCC ≤ 5.5 V)		4.0	MHz
		(2.5 V ≤ VCC ≤ 4.0 V)		(2×VCC)-4	MHz
$f(XIN)$	Main clock input oscillation frequency (Note 4)	High-speed mode (4.0 V ≤ VCC ≤ 5.5 V)		8.0	MHz
		High-speed mode (2.5 V ≤ VCC ≤ 4.0 V)		(4×VCC)-8	MHz
		Middle-speed mode		8.0	MHz
$f(XCIN)$	Sub-clock input oscillation frequency (Notes 4, 5)		32.768	50	kHz

- Notes**
- 1: The total output current is the sum of all the currents flowing through all the applicable ports. The total average current is an average value measured over 100 ms. The total peak current is the peak value of all the currents.
 - 2: The peak output current is the peak current flowing in each port.
 - 3: The average output current is an average value measured over 100 ms.
 - 4: When the oscillation frequency has a duty cycle of 50 %.
 - 5: When using the microcomputer in low-speed mode, make sure that the sub-clock input oscillation frequency on condition that $f(XCIN) < f(XIN)/3$.

Table 18 Electrical characteristics (Standard, One Time PROM version)

(VCC =4.0 to 5.5 V, Ta = -20 to 85°C, unless otherwise noted)

Symbol	Parameter	Test conditions	Limits			Unit
			Min.	Typ.	Max.	
VOH	“H” output voltage P00–P07, P10–P17	IOH = -2.5 mA	VCC-2.0			V
		IOH = -0.6 mA VCC = 2.5 V	VCC-1.0			V
VOH	“H” output voltage P20–P27, P41–P47, P50–P57, P60–P67, P70, P71 (Note)	IOH = -5 mA	VCC-2.0			V
		IOH = -1.25 mA	VCC-0.5			V
		IOH = -1.25 mA VCC = 2.5 V	VCC-1.0			V
VOL	“L” output voltage P00–P07, P10–P17	IOI = 5 mA			2.0	V
		IOI = 1.25 mA			0.5	V
		IOI = 1.25 mA VCC = 2.5 V			1.0	V
VOL	“L” output voltage P20–P27, P41–P47, P50–P57, P60–P67, P70, P71 (Note)	IOI = 10 mA			2.0	V
		IOI = 2.5 mA			0.5	V
		IOI = 2.5 mA VCC = 2.5 V			1.0	V
VT+ – VT-	Hysteresis INT0–INT3, ADT, CNTR0, CNTR1, P20–P27			0.5		V
VT+ – VT-	Hysteresis SCLK, RxD			0.5		V
VT+ – VT-	Hysteresis RESET	RESET : VCC = 2.5 V to 5.5 V		0.5		V
IIH	“H” input current P00–P07, P10–P17, P34–P37	VI = VCC Pull-downs “off”			5.0	μA
		VCC = 5 V, VI = VCC Pull-downs “on”	30	70	140	μA
		VCC = 3 V, VI = VCC Pull-downs “on”	6.0	25	45	μA
IIH	“H” input current P20–P27, P40–P47, P50–P57, P60–P67, P70, P71 (Note)	VI = VCC			5.0	μA
IIH	“H” input current RESET	VI = VCC			5.0	μA
IIH	“H” input current XIN	VI = VCC		4.0		μA
IIL	“L” input current P00–P07, P10–P17, P34–P37, P40	VI = VSS			-5.0	μA
IIL	“L” input current P20–P27, P41–P47, P50–P57, P60–P67, P70, P71 (Note)	VI = VSS Pull-ups “off”			-5.0	μA
		VCC = 5 V, VI = VSS Pull-ups “on”	-30	-70	-140	μA
		VCC = 3 V, VI = VSS Pull-ups “on”	-6.0	-25	-45	μA
IIL	“L” input current RESET	VI = VSS			-5.0	μA
IIL	“L” input current XIN	VI = VSS		-4.0		μA

Note: When “1” is set to port Xc switch bit (bit 4 at address 003B16) of the CPU mode register, the drive ability of port P70 is different from the value above mentioned.

Table 19 Electrical characteristics (Standard, One Time PROM version)

(VCC = 2.5 to 5.5 V, Ta = -20 to 85 °C, unless otherwise noted)

Symbol	Parameter	Test conditions	Limits			Unit
			Min.	Typ.	Max.	
VRAM	RAM retention voltage	At clock stop mode	2.0		5.5	V
ICC	Power source current	<ul style="list-style-type: none"> High-speed mode, VCC = 5 V f(XIN) = 8 MHz f(XCIN) = 32.768 kHz Output transistors "off" A-D converter in operating 		6.4	13	mA
		<ul style="list-style-type: none"> High-speed mode, VCC = 5 V f(XIN) = 8 MHz (in WIT state) f(XCIN) = 32.768 kHz Output transistors "off" A-D converter stopped 		1.6	3.2	mA
		<ul style="list-style-type: none"> Low-speed mode, VCC = 5 V, Ta ≤ 55°C f(XIN) = stopped f(XCIN) = 32.768 kHz Output transistors "off" 		25	36	μA
		<ul style="list-style-type: none"> Low-speed mode, VCC = 5 V, Ta = 25°C f(XIN) = stopped f(XCIN) = 32.768 kHz (in WIT state) Output transistors "off" 		7.0	14	μA
		<ul style="list-style-type: none"> Low-speed mode, VCC = 3 V, Ta ≤ 55°C f(XIN) = stopped f(XCIN) = 32.768 kHz Output transistors "off" 		15	22	μA
		<ul style="list-style-type: none"> Low-speed mode, VCC = 3 V, Ta = 25°C f(XIN) = stopped f(XCIN) = 32.768 kHz (in WIT state) Output transistors "off" 		4.5	9.0	μA
		All oscillation stopped (in STP state) Output transistors "off"	Ta = 25 °C Ta = 85 °C		0.1	1.0

Table 20 A-D converter characteristics (Standard, One Time PROM version)

(VCC = 4.0 to 5.5 V, VSS = 0 V, Ta = -20 to 85 °C, 4 MHz ≤ f(XIN) ≤ 8 MHz, middle-/high-speed mode, unless otherwise noted)

Symbol	Parameter	Test conditions	Limits			Unit
			Min.	Typ.	Max.	
-	Resolution				8	Bits
-	Absolute accuracy (excluding quantization error)	VCC = VREF = 5V			±2	LSB
tCONV	Conversion time	f(XIN) = 8 MHz			12.5 (Note)	μs
RLADDER	Ladder resistor		12	35	100	kΩ
IVREF	Reference power source input current	VREF = 5 V	50	150	200	μA
I _A	Analog port input current				5.0	μA

Note: When an internal trigger is used in middle-speed mode, it is 14 μs.

Table 21 Timing requirements 1 (Standard, One Time PROM version)

(VCC = 4.0 to 5.5 V, VSS = 0 V, Ta = -20 to 85 °C, unless otherwise noted)

Symbol	Parameter	Limits			Unit
		Min.	Typ.	Max.	
tw(RESET)	Reset input "L" pulse width	2			μs
tc(XIN)	Main clock input cycle time (XIN input)	125			ns
twH(XIN)	Main clock input "H" pulse width	45			ns
twL(XIN)	Main clock input "L" pulse width	40			ns
tc(CNTR)	CNTR0, CNTR1 input cycle time	250			ns
twH(CNTR)	CNTR0, CNTR1 input "H" pulse width	105			ns
twL(CNTR)	CNTR0, CNTR1 input "L" pulse width	105			ns
twH(INT)	INT0 to INT3 input "H" pulse width	80			ns
twL(INT)	INT0 to INT3 input "L" pulse width	80			ns
tc(SCLK)	Serial I/O clock input cycle time (Note)	800			ns
twH(SCLK)	Serial I/O clock input "H" pulse width (Note)	370			ns
twL(SCLK)	Serial I/O clock input "L" pulse width (Note)	370			ns
tsu(RxD-SCLK)	Serial I/O input set up time	220			ns
th(SCLK-RxD)	Serial I/O input hold time	100			ns

Note: When bit 6 of address 001A16 is "1" (clock synchronous).
Divide this value by four when bit 6 of address 001A16 is "0" (UART).

Table 22 Timing requirements 2 (Standard, One Time PROM version)

(VCC = 2.5 to 4.0 V, VSS = 0 V, Ta = -20 to 85 °C, unless otherwise noted)

Symbol	Parameter	Limits			Unit
		Min.	Typ.	Max.	
tw(RESET)	Reset input "L" pulse width	2			μs
tc(XIN)	Main clock input cycle time (XIN input)	125			ns
twH(XIN)	Main clock input "H" pulse width	45			ns
twL(XIN)	Main clock input "L" pulse width	40			ns
tc(CNTR)	CNTR0, CNTR1 input cycle time	500/(VCC-2)			ns
twH(CNTR)	CNTR0, CNTR1 input "H" pulse width	250/(VCC-2)-20			ns
twL(CNTR)	CNTR0, CNTR1 input "L" pulse width	250/(VCC-2)-20			ns
twH(INT)	INT0 to INT3 input "H" pulse width	230			ns
twL(INT)	INT0 to INT3 input "L" pulse width	230			ns
tc(SCLK)	Serial I/O clock input cycle time (Note)	2000			ns
twH(SCLK)	Serial I/O clock input "H" pulse width (Note)	950			ns
twL(SCLK)	Serial I/O clock input "L" pulse width (Note)	950			ns
tsu(RxD-SCLK)	Serial I/O input set up time	400			ns
th(SCLK-RxD)	Serial I/O input hold time	200			ns

Note: When bit 6 of address 001A16 is "1" (clock synchronous).
Divide this value by four when bit 6 of address 001A16 is "0" (UART).

Table 23 Switching characteristics 1 (Standard, One Time PROM version)

(VCC = 4.0 to 5.5 V, VSS = 0 V, Ta = -20 to 85 °C, unless otherwise noted)

Symbol	Parameter	Limits			Unit
		Min.	Typ.	Max.	
twH(SCLK)	Serial I/O clock output "H" pulse width	tc (SCLK)/2-30			ns
twL(SCLK)	Serial I/O clock output "L" pulse width	tc (SCLK)/2-30			ns
td(SCLK-TxD)	Serial I/O output delay time (Note 1)			140	ns
tv(SCLK-TxD)	Serial I/O output valid time (Note 1)	-30			ns
tr(SCLK)	Serial I/O clock output rising time			30	ns
tf(SCLK)	Serial I/O clock output falling time			30	ns
tr(CMOS)	CMOS output rising time (Note 2)		10	30	ns
tf(CMOS)	CMOS output falling time (Note 2)		10	30	ns

Notes 1: When the P45/TxD P-channel output disable bit of the UART control register (bit 4 of address 001B16) is "0".

2: XOUT and XCOUNT pins are excluded.

Table 24 Switching characteristics 2 (Standard, One Time PROM version)

(VCC = 2.5 to 4.0 V, VSS = 0 V, Ta = -20 to 85 °C, unless otherwise noted)

Symbol	Parameter	Limits			Unit
		Min.	Typ.	Max.	
twH(SCLK)	Serial I/O clock output "H" pulse width	tc (SCLK)/2-50			ns
twL(SCLK)	Serial I/O clock output "L" pulse width	tc (SCLK)/2-50			ns
td(SCLK-TxD)	Serial I/O output delay time (Note 1)			350	ns
tv(SCLK-TxD)	Serial I/O output valid time (Note 1)	-30			ns
tr(SCLK)	Serial I/O clock output rising time			50	ns
tf(SCLK)	Serial I/O clock output falling time			50	ns
tr(CMOS)	CMOS output rising time (Note 2)		20	50	ns
tf(CMOS)	CMOS output falling time (Note 2)		20	50	ns

Notes 1: When the P45/TxD P-channel output disable bit of the UART control register (bit 4 of address 001B16) is "0".

2: XOUT and XCOUNT pins are excluded.

Table 25 Absolute maximum ratings (Extended operating temperature version)

Symbol	Parameter	Conditions	Ratings	Unit
VCC	Power source voltage	All voltages are based on V _{SS} . Output transistors are cut off.	-0.3 to 6.5	V
V _I	Input voltage P00-P07, P10-P17, P20-P27, P34-P37, P40-P47, P50-P57 P60-P67, P70, P71		-0.3 to V _{CC} +0.3	V
V _I	Input voltage V _{L1}		-0.3 to V _{L2}	V
V _I	Input voltage V _{L2}		V _{L1} to V _{L3}	V
V _I	Input voltage V _{L3}		V _{L2} to V _{CC} +0.3	V
V _I	Input voltage RESET, X _{IN}		-0.3 to V _{CC} +0.3	V
V _O	Output voltage P00-P07, P10-P17		At output port	-0.3 to V _{CC} +0.3
		At segment output	-0.3 to V _{L3}	V
V _O	Output voltage P34-P37	At segment output	-0.3 to V _{L3}	V
V _O	Output voltage P20-P27, P41-P47, P50-P57, P60-P67, P70, P71		-0.3 to V _{CC} +0.3	V
V _O	Output voltage SEG0-SEG11		-0.3 to V _{L3}	V
V _O	Output voltage X _{OUT}		-0.3 to V _{CC} +0.3	V
P _d	Power dissipation	T _a = 25°C	300	mW
T _{opr}	Operating temperature		-40 to 85	°C
T _{stg}	Storage temperature		-65 to 150	°C

Table 26 Recommended operating conditions (Extended operating temperature version)

(V_{CC} = 2.0 to 5.5 V, T_a = -20 to 85 °C, and V_{CC} = 3.0 to 5.5 V, T_a = -40 to -20°C, unless otherwise noted)

Symbol	Parameter		Limits			Unit	
			Min.	Typ.	Max.		
VCC	Power source voltage	High-speed mode f(X _{IN}) = 8 MHz		4.0	5.0	5.5	V
		Middle-speed mode f(X _{IN}) = 8 MHz	T _a = -20 to 85°C	2.0	5.0	5.5	
			T _a = -40 to -20°C	3.0	5.0	5.5	
		Low-speed mode	T _a = -20 to 85°C	2.0	5.0	5.5	
			T _a = -40 to -20°C	3.0	5.0	5.5	
V _{SS}	Power source voltage			0		V	
V _{REF}	A-D conversion reference voltage		2.0		V _{CC}	V	
AV _{SS}	Analog power source voltage			0		V	
V _{IA}	Analog input voltage AN0-AN7		AV _{SS}		V _{CC}	V	
V _{IH}	"H" input voltage	P00-P07, P10-P17, P34-P37, P40, P41, P45, P47, P52, P53, P56, P60-P67, P70, P71 (CM4 = 0)	0.7V _{CC}		V _{CC}	V	
V _{IH}	"H" input voltage	P20-P27, P42-P44, P46, P50, P51, P54, P55, P57	0.8V _{CC}		V _{CC}	V	
V _{IH}	"H" input voltage	RESET	0.8V _{CC}		V _{CC}	V	
V _{IH}	"H" input voltage	X _{IN}	0.8V _{CC}		V _{CC}	V	
V _{IL}	"L" input voltage	P00-P07, P10-P17, P34-P37, P40, P41, P45, P47, P52, P53, P56, P60-P67, P70, P71 (CM4 = 0)	0		0.3 V _{CC}	V	
V _{IL}	"L" input voltage	P20-P27, P42-P44, P46, P50, P51, P54, P55, P57	0		0.2 V _{CC}	V	
V _{IL}	"L" input voltage	RESET	0		0.2 V _{CC}	V	
V _{IL}	"L" input voltage	X _{IN}	0		0.2 V _{CC}	V	

Table 27 Recommended operating conditions (Extended operating temperature version)

(VCC = 2.0 to 5.5 V, Ta = -20 to 85 °C, and VCC = 3.0 to 5.5 V, Ta = -40 to -20° C, unless otherwise noted)

Symbol	Parameter		Limits			Unit
			Min.	Typ.	Max.	
ΣIOH(peak)	"H" total peak output current	P00–P07, P10–P17, P20–P27 (Note 1)			-40	mA
ΣIOH(peak)	"H" total peak output current	P41–P47, P50–P57, P60–P67, P70, P71 (Note 1)			-40	mA
ΣIOL(peak)	"L" total peak output current	P00–P07, P10–P17, P20–P27 (Note 1)			40	mA
ΣIOL(peak)	"L" total peak output current	P41–P47, P50–P57, P60–P67, P70, P71 (Note 1)			40	mA
ΣIOH(avg)	"H" total average output current	P00–P07, P10–P17, P20–P27 (Note 1)			-20	mA
ΣIOH(avg)	"H" total average output current	P41–P47, P50–P57, P60–P67, P70, P71 (Note 1)			-20	mA
ΣIOL(avg)	"L" total average output current	P00–P07, P10–P17, P20–P27 (Note 1)			20	mA
ΣIOL(avg)	"L" total average output current	P41–P47, P50–P57, P60–P67, P70, P71 (Note 1)			20	mA
IOH(peak)	"H" peak output current	P00–P07, P10–P17 (Note 2)			-2	mA
IOH(peak)	"H" peak output current	P20–P27, P41–P47, P50–P57, P60–P67, P70, P71 (Note 2)			-5	mA
IOL(peak)	"L" peak output current	P00–P07, P10–P17 (Note 2)			5	mA
IOL(peak)	"L" peak output current	P20–P27, P41–P47, P50–P57, P60–P67, P70, P71 (Note 2)			10	mA
IOH(avg)	"H" average output current	P00–P07, P10–P17 (Note 3)			-1.0	mA
IOH(avg)	"H" average output current	P20–P27, P41–P47, P50–P57, P60–P67, P70, P71 (Note 3)			-2.5	mA
IOL(avg)	"L" average output current	P00–P07, P10–P17 (Note 3)			2.5	mA
IOL(avg)	"L" average output current	P20–P27, P41–P47, P50–P57, P60–P67, P70, P71 (Note 3)			5.0	mA
f(CNTR0)	Input frequency for timers X and Y (duty cycle 50%)	(4.0 V ≤ VCC ≤ 5.5 V)			4.0	MHz
f(CNTR1)		(2.0 V ≤ VCC ≤ 4.0 V)			VCC	MHz
f(XIN)	Main clock input oscillation frequency (Note 4)	High-speed mode (4.0 V ≤ VCC ≤ 5.5 V)			8.0	MHz
		High-speed mode (2.0 V ≤ VCC ≤ 4.0 V)			2XVCC	MHz
		Middle-speed mode			8.0	MHz
f(XCIN)	Sub-clock input oscillation frequency (Notes 4, 5)		32.768	50	kHz	

Notes 1: The total output current is the sum of all the currents flowing through all the applicable ports. The total average current is an average value measured over 100 ms. The total peak current is the peak value of all the currents.

2: The peak output current is the peak current flowing in each port.

3: The average output current is an average value measured over 100 ms.

4: When the oscillation frequency has a duty cycle of 50 %.

5: When using the microcomputer in low-speed mode, make sure that the sub-clock input oscillation frequency on condition that $f(XCIN) < f(XIN)/3$.

Table 28 Electrical characteristics (Extended operating temperature version)

(VCC = 2.0 to 5.5 V, Ta = -20 to 85 °C, and VCC = 3.0 to 5.5 V, Ta = -40 to -20 °C, unless otherwise noted)

Symbol	Parameter	Test conditions	Limits			Unit	
			Min.	Typ.	Max.		
VOH	"H" output voltage P00-P07, P10-P17	IOH = -2.5 mA	VCC-2.0			V	
		IOH = -0.6 mA VCC = 3.0 V	VCC-0.9			V	
VOH	"H" output voltage P20-P27, P41-P47, P50-P57, P60-P67, P70, P71 (Note)	IOH = -5 mA	VCC-2.0			V	
		IOH = -1.25 mA	VCC-0.5			V	
		IOH = -1.25 mA VCC = 3.0 V	VCC-0.9			V	
VOL	"L" output voltage P00-P07, P10-P17	IOL = 5 mA			2.0	V	
		IOL = 1.25 mA			0.5	V	
		IOL = 1.25 mA VCC = 3.0 V			1.1	V	
VOL	"L" output voltage P20-P27, P41-P47, P50-P57, P60-P67, P70, P71 (Note)	IOL = 10 mA			2.0	V	
		IOL = 2.5 mA			0.5	V	
		IOL = 2.5 mA VCC = 3.0 V			1.1	V	
VT+ - VT-	Hysteresis INT0-INT3, ADT, CNTR0, CNTR1, P20-P27			0.5		V	
VT+ - VT-	Hysteresis SCLK, RxD			0.5		V	
VT+ - VT-	Hysteresis RESET	RESET : VCC = 2.0 V to 5.5 V			0.5		V
IIH	"H" input current P00-P07, P10-P17, P34-P37	VI = VCC Pull-downs "off"			5.0	μA	
		VCC = 5 V, VI = VCC Pull-downs "on"	30	70	170	μA	
		VCC = 3 V, VI = VCC Pull-downs "on"	6.0	25	55	μA	
IIH	"H" input current P20-P27, P40-P47, P50-P57, P60-P67, P70, P71 (Note)	VI = VCC			5.0	μA	
IIH	"H" input current RESET	VI = VCC			5.0	μA	
IIH	"H" input current XIN	VI = VCC		4.0		μA	
IIL	"L" input current P00-P07, P10-P17, P34-P37, P40	VI = VSS			-5.0	μA	
IIL	"L" input current P20-P27, P41-P47, P50-P57, P60-P67, P70, P71 (Note)	VI = VSS Pull-ups "off"			-5.0	μA	
		VCC = 5 V, VI = VSS Pull-ups "on"	-30	-70	-140	μA	
		VCC = 3 V, VI = VSS Pull-ups "on"	-6.0	-25	-45	μA	
IIL	"L" input current RESET	VI = VSS			-5.0	μA	
IIL	"L" input current XIN	VI = VSS		-4.0		μA	

Note: When "1" is set to port XC switch bit (bit 4 at address 003B16) of CPU mode register, the drive ability of port P70 is different from the value above mentioned.

Table 29 Electrical characteristics (Extended operating temperature version)

(VCC = 2.0 to 5.5 V, Ta = -20 to 85 °C, and VCC = 3.0 to 5.5 V, Ta = -40 to -20 °C, unless otherwise noted)

Symbol	Parameter	Test conditions	Limits			Unit
			Min.	Typ.	Max.	
VRAM	RAM retention voltage	At clock stop mode	2.0		5.5	V
ICC	Power source current	<ul style="list-style-type: none"> High-speed mode, VCC = 5 V f(XIN) = 8 MHz f(XCIN) = 32.768 kHz Output transistors "off" A-D converter in operating 		6.4	13	mA
		<ul style="list-style-type: none"> High-speed mode, VCC = 5 V f(XIN) = 8 MHz (in WIT state) f(XCIN) = 32.768 kHz Output transistors "off" A-D converter stopped 		1.6	3.2	mA
		<ul style="list-style-type: none"> Low-speed mode, VCC = 5 V, Ta ≤ 55°C f(XIN) = stopped f(XCIN) = 32.768 kHz Output transistors "off" 		25	36	μA
		<ul style="list-style-type: none"> Low-speed mode, VCC = 5 V, Ta = 25°C f(XIN) = stopped f(XCIN) = 32.768 kHz (in WIT state) Output transistors "off" 		7.0	14	μA
		<ul style="list-style-type: none"> Low-speed mode, VCC = 3 V, Ta ≤ 55°C f(XIN) = stopped f(XCIN) = 32.768 kHz Output transistors "off" 		15	22	μA
		<ul style="list-style-type: none"> Low-speed mode, VCC = 3 V, Ta = 25°C f(XIN) = stopped f(XCIN) = 32.768 kHz (in WIT state) Output transistors "off" 		4.5	9.0	μA
		All oscillation stopped (in STP state) Output transistors "off"	Ta = 25 °C Ta = 85 °C		0.1	1.0

Table 30 A-D converter characteristics (Extended operating temperature version)

(VCC = 3.0 to 5.5 V, VSS = AVSS = 0 V, Ta = -40 to 85 °C, 4 MHz ≤ f(XIN) ≤ 8 MHz, in middle/high-speed mode unless otherwise noted)

Symbol	Parameter	Test conditions	Limits			Unit
			Min.	Typ.	Max.	
-	Resolution				8	Bits
-	Absolute accuracy (excluding quantization error)	VCC = VREF = 4.0V to 5.5V f(XIN) = 8 MHz			±2	LSB
		VCC = VREF = 3.0 V to 4.0V f(XIN) = 2 × VCC MHz				
tCONV	Conversion time	f(XIN) = 8 MHz			12.5 (Note)	μs
RLADDER	Ladder resistor		12	35	100	kΩ
IVREF	Reference power source input current	VREF = 5 V	50	150	200	μA
I _A	Analog port input current				5.0	μA

Note: When an internal trigger is used in middle-speed mode, it is 14 μs.

Table 31 Timing requirements 1 (Extended operating temperature version)

(VCC = 4.0 to 5.5 V, VSS = 0 V, Ta = -40 to 85 °C, unless otherwise noted)

Symbol	Parameter	Limits			Unit
		Min.	Typ.	Max.	
tw(RESET)	Reset input "L" pulse width	2			μs
tc(XIN)	Main clock input cycle time (XIN input)	125			ns
twH(XIN)	Main clock input "H" pulse width	45			ns
twL(XIN)	Main clock input "L" pulse width	40			ns
tc(CNTR)	CNTR0, CNTR1 input cycle time	250			ns
twH(CNTR)	CNTR0, CNTR1 input "H" pulse width	105			ns
twL(CNTR)	CNTR0, CNTR1 input "L" pulse width	105			ns
twH(INT)	INT0 to INT3 input "H" pulse width	80			ns
twL(INT)	INT0 to INT3 input "L" pulse width	80			ns
tc(SCLK)	Serial I/O clock input cycle time (Note)	800			ns
twH(SCLK)	Serial I/O clock input "H" pulse width (Note)	370			ns
twL(SCLK)	Serial I/O clock input "L" pulse width (Note)	370			ns
tsu(RxD-SCLK)	Serial I/O input set up time	220			ns
th(SCLK-RxD)	Serial I/O input hold time	100			ns

Note: When bit 6 of address 001A16 is "1" (clock synchronous).
Divide this value by four when bit 6 of address 001A16 is "0" (UART).

Table 32 Timing requirements 2 (Extended operating temperature version)

(VCC = 2.0 to 4.0 V, VSS = 0 V, Ta = -20 to 85 °C, and VCC = 3.0 to 4.0 V, Ta = -40 to -20 °C, unless otherwise noted)

Symbol	Parameter	Limits			Unit
		Min.	Typ.	Max.	
tw(RESET)	Reset input "L" pulse width	2			μs
tc(XIN)	Main clock input cycle time (XIN input)	125			ns
twH(XIN)	Main clock input "H" pulse width	45			ns
twL(XIN)	Main clock input "L" pulse width	40			ns
tc(CNTR)	CNTR0, CNTR1 input cycle time	900/(VCC-0.4)			ns
twH(CNTR)	CNTR0, CNTR1 input "H" pulse width	450/(VCC-0.4)-20			ns
twL(CNTR)	CNTR0, CNTR1 input "L" pulse width	450/(VCC-0.4)-20			ns
twH(INT)	INT0 to INT3 input "H" pulse width	230			ns
twL(INT)	INT0 to INT3 input "L" pulse width	230			ns
tc(SCLK)	Serial I/O clock input cycle time (Note)	2000			ns
twH(SCLK)	Serial I/O clock input "H" pulse width (Note)	950			ns
twL(SCLK)	Serial I/O clock input "L" pulse width (Note)	950			ns
tsu(RxD-SCLK)	Serial I/O input set up time	400			ns
th(SCLK-RxD)	Serial I/O input hold time	200			ns

Note: When bit 6 of address 001A16 is "1" (clock synchronous).
Divide this value by four when bit 6 of address 001A16 is "0" (UART).

Table 33 Switching characteristics 1 (Extended operating temperature version)

(VCC = 4.0 to 5.5 V, VSS = 0 V, Ta = -40 to 85 °C, unless otherwise noted)

Symbol	Parameter	Limits			Unit
		Min.	Typ.	Max.	
twH(SCLK)	Serial I/O clock output "H" pulse width	tc (SCLK)/2-30			ns
twL(SCLK)	Serial I/O clock output "L" pulse width	tc (SCLK)/2-30			ns
td(SCLK-TxD)	Serial I/O output delay time (Note 1)			140	ns
tv(SCLK-TxD)	Serial I/O output valid time (Note 1)	-30			ns
tr(SCLK)	Serial I/O clock output rising time			30	ns
tf(SCLK)	Serial I/O clock output falling time			30	ns
tr(CMOS)	CMOS output rising time (Note 2)		10	30	ns
tf(CMOS)	CMOS output falling time (Note 2)		10	30	ns

Notes 1: When the P45/TxD P-channel output disable bit of the UART control register (bit 4 of address 001B16) is "0".**2:** XOUT and XCOUNT pins are excluded.**Table 34 Switching characteristics 2 (Extended operating temperature version)**

(VCC = 2.0 to 4.0 V, VSS = 0 V, Ta = -20 to 85 °C, and VCC = 3.0 to 4.0 V, VSS = 0 V, Ta = -40 to -20 °C, unless otherwise noted)

Symbol	Parameter	Limits			Unit
		Min.	Typ.	Max.	
twH(SCLK)	Serial I/O clock output "H" pulse width	tc (SCLK)/2-50			ns
twL(SCLK)	Serial I/O clock output "L" pulse width	tc (SCLK)/2-50			ns
td(SCLK-TxD)	Serial I/O output delay time (Note 1)			350	ns
tv(SCLK-TxD)	Serial I/O output valid time (Note 1)	-30			ns
tr(SCLK)	Serial I/O clock output rising time			50	ns
tf(SCLK)	Serial I/O clock output falling time			50	ns
tr(CMOS)	CMOS output rising time (Note 2)		20	50	ns
tf(CMOS)	CMOS output falling time (Note 2)		20	50	ns

Notes 1: When the P45/TxD P-channel output disable bit of the UART control register (bit 4 of address 001B16) is "0".**2:** XOUT and XCOUNT pins are excluded.

Table 35 Absolute maximum ratings (M version)

Symbol	Parameter	Conditions	Ratings	Unit
VCC	Power source voltage	All voltages are based on VSS. Output transistors are cut off.	-0.3 to 7.0	V
Vi	Input voltage P00-P07, P10-P17, P20-P27, P34-P37, P40-P47, P50-P57 P60-P67, P70, P71		-0.3 to VCC +0.3	V
Vi	Input voltage VL1		-0.3 to VL2	V
Vi	Input voltage VL2		VL1 to VL3	V
Vi	Input voltage VL3		VL2 to VCC +0.3	V
Vi	Input voltage RESET, XIN		-0.3 to VCC +0.3	V
Vo	Output voltage P00-P07, P10-P17		At output port	-0.3 to VCC +0.3
		At segment output	-0.3 to VL3 +0.3	V
Vo	Output voltage P34-P37	At segment output	-0.3 to VL3 +0.3	V
Vo	Output voltage P20-P27, P41-P47, P50-P57, P60-P67, P70, P71		-0.3 to VCC +0.3	V
Vo	Output voltage SEG0-SEG11		-0.3 to VL3 +0.3	V
Vo	Output voltage XOUT		-0.3 to VCC +0.3	V
Pd	Power dissipation	Ta = 25°C	300	mW
Topr	Operating temperature		-20 to 85	°C
Tstg	Storage temperature		-40 to 150	°C

Table 36 Recommended operating conditions (M version)

(VCC = 2.2 to 5.5 V, Ta = -20 to 85 °C, unless otherwise noted)

Symbol	Parameter	Limits			Unit	
		Min.	Typ.	Max.		
VCC	Power source voltage	High-speed mode f(XIN) = 8 MHz	4.0	5.0	5.5	V
		Middle-speed mode f(XIN) = 8 MHz	2.2	5.0	5.5	
		Low-speed mode	2.2	5.0	5.5	
VSS	Power source voltage		0		V	
VREF	A-D conversion reference voltage	2.0		VCC	V	
AVSS	Analog power source voltage		0		V	
VIA	Analog input voltage AN0-AN7	AVSS		VCC	V	

Table 37 Recommended operating conditions (M version)

(VCC = 2.5 to 5.5 V, Ta = -20 to 85 °C, unless otherwise noted)

Symbol	Parameter	Limits			Unit
		Min.	Typ.	Max.	
V _{IH}	"H" input voltage P00-P07, P10-P17,P34-P37, P40, P41, P45, P47, P52, P53,P56,P60-P67,P70,P71 (CM4= 0)	0.7V _{CC}		V _{CC}	V
V _{IH}	"H" input voltage P20-P27, P42-P44,P46,P50, P51, P54, P55, P57	0.8V _{CC}		V _{CC}	V
V _{IH}	"H" input voltage RESET	0.8V _{CC}		V _{CC}	V
V _{IH}	"H" input voltage X _{IN}	0.8V _{CC}		V _{CC}	V
V _{IL}	"L" input voltage P00-P07, P10-P17,P34-P37, P40, P41, P45, P47, P52, P53, P56,P60-P67,P70,P71 (CM4= 0)	0		0.3 V _{CC}	V
V _{IL}	"L" input voltage P20-P27, P42-P44,P46,P50, P51, P54, P55, P57	0		0.2 V _{CC}	V
V _{IL}	"L" input voltage RESET	0		0.2 V _{CC}	V
V _{IL}	"L" input voltage X _{IN}	0		0.2 V _{CC}	V

Table 38 Recommended operating conditions (M version)

(VCC = 2.2 to 5.5 V, Ta = -20 to 85 °C, unless otherwise noted)

Symbol	Parameter	Limits			Unit
		Min.	Typ.	Max.	
V _{IH}	"H" input voltage P00-P07, P10-P17,P34-P37, P40, P41, P45, P47, P52, P53,P56,P60-P67,P70,P71 (CM4= 0)	0.8V _{CC}		V _{CC}	V
V _{IH}	"H" input voltage P20-P27, P42-P44,P46,P50, P51, P54, P55, P57	0.95V _{CC}		V _{CC}	V
V _{IH}	"H" input voltage RESET	0.95V _{CC}		V _{CC}	V
V _{IH}	"H" input voltage X _{IN}	0.95V _{CC}		V _{CC}	V
V _{IL}	"L" input voltage P00-P07, P10-P17,P34-P37, P40, P41, P45, P47, P52, P53, P56,P60-P67,P70,P71 (CM4= 0)	0		0.2 V _{CC}	V
V _{IL}	"L" input voltage P20-P27, P42-P44,P46,P50, P51, P54, P55, P57	0		0.05 V _{CC}	V
V _{IL}	"L" input voltage RESET	0		0.05 V _{CC}	V
V _{IL}	"L" input voltage X _{IN}	0		0.05 V _{CC}	V

Table 39 Recommended operating conditions (M version)

(VCC = 2.2 to 5.5 V, Ta = -20 to 85 °C, unless otherwise noted)

Symbol	Parameter	Limits			Unit
		Min.	Typ.	Max.	
ΣIOH(peak)	"H" total peak output current P00–P07, P10–P17, P20–P27 (Note 1)			-40	mA
ΣIOH(peak)	"H" total peak output current P41–P47, P50–P57, P60–P67, P70, P71 (Note 1)			-40	mA
ΣIOL(peak)	"L" total peak output current P00–P07, P10–P17, P20–P27 (Note 1)			40	mA
ΣIOL(peak)	"L" total peak output current P41–P47, P50–P57, P60–P67, P70, P71 (Note 1)			40	mA
ΣIOH(avg)	"H" total average output current P00–P07, P10–P17, P20–P27 (Note 1)			-20	mA
ΣIOH(avg)	"H" total average output current P41–P47, P50–P57, P60–P67, P70, P71 (Note 1)			-20	mA
ΣIOL(avg)	"L" total average output current P00–P07, P10–P17, P20–P27 (Note 1)			20	mA
ΣIOL(avg)	"L" total average output current P41–P47, P50–P57, P60–P67, P70, P71 (Note 1)			20	mA
IOH(peak)	"H" peak output current P00–P07, P10–P17 (Note 2)			-2	mA
IOH(peak)	"H" peak output current P20–P27, P41–P47, P50–P57, P60–P67, P70, P71 (Note 2)			-5	mA
IOL(peak)	"L" peak output current P00–P07, P10–P17 (Note 2)			5	mA
IOL(peak)	"L" peak output current P20–P27, P41–P47, P50–P57, P60–P67, P70, P71 (Note 2)			10	mA
IOH(avg)	"H" average output current P00–P07, P10–P17 (Note 3)			-1.0	mA
IOH(avg)	"H" average output current P20–P27, P41–P47, P50–P57, P60–P67, P70, P71 (Note 3)			-2.5	mA
IOL(avg)	"L" average output current P00–P07, P10–P17 (Note 3)			2.5	mA
IOL(avg)	"L" average output current P20–P27, P41–P47, P50–P57, P60–P67, P70, P71 (Note 3)			5.0	mA
f(CNTR0) f(CNTR1)	Input frequency for timers X and Y (duty cycle 50%)	(4.0 V ≤ VCC ≤ 5.5 V)		4.0	MHz
		(2.2 V ≤ VCC ≤ 4.0 V)		(10×VCC-4)/9	MHz
f(XIN)	Main clock input oscillation frequency (Note 4)	High-speed mode (4.0 V ≤ VCC ≤ 5.5 V)		8.0	MHz
		High-speed mode (2.2 V ≤ VCC ≤ 4.0 V)		(20×VCC-8)/9	MHz
		Middle-speed mode		8.0	MHz
f(XCIN)	Sub-clock input oscillation frequency (Notes 4, 5)		32.768	50	kHz

Notes 1: The total output current is the sum of all the currents flowing through all the applicable ports. The total average current is an average value measured over 100 ms. The total peak current is the peak value of all the currents.

2: The peak output current is the peak current flowing in each port.

3: The average output current is an average value measured over 100 ms.

4: When the oscillation frequency has a duty cycle of 50%.

5: When using the microcomputer in low-speed mode, make sure that the sub-clock input oscillation frequency on condition that f(XCIN) < f(XIN)/3.

Table 40 Electrical characteristics (M version)

(VCC = 4.0 to 5.5 V, Ta = -20 to 85 °C, unless otherwise noted)

Symbol	Parameter	Test conditions	Limits			Unit
			Min.	Typ.	Max.	
VOH	“H” output voltage P00–P07, P10–P17	IOH = -2.5 mA	VCC-2.0			V
		IOH = -0.6 mA VCC = 2.5 V	VCC-1.0			V
VOH	“H” output voltage P20–P27, P41–P47, P50–P57, P60–P67, P70, P71 (Note)	IOH = -5 mA	VCC-2.0			V
		IOH = -1.25 mA	VCC-0.5			V
		IOH = -1.25 mA VCC = 2.5 V	VCC-1.0			V
VOL	“L” output voltage P00–P07, P10–P17	IOI = 5 mA			2.0	V
		IOI = 1.25 mA			0.5	V
		IOI = 1.25 mA VCC = 2.5 V			1.0	V
VOL	“L” output voltage P20–P27, P41–P47, P50–P57, P60–P67, P70, P71 (Note)	IOI = 10 mA			2.0	V
		IOI = 2.5 mA			0.5	V
		IOI = 2.5 mA VCC = 2.5 V			1.0	V
VT+ – VT-	Hysteresis INT0–INT3, ADT, CNTR0, CNTR1, P20–P27			0.5		V
VT+ – VT-	Hysteresis SCLK, RxD			0.5		V
VT+ – VT-	Hysteresis RESET	RESET : VCC = 2.2 V to 5.5 V		0.5		V
IIH	“H” input current P00–P07, P10–P17, P34–P37	VI = VCC Pull-downs “off”			5.0	μA
		VCC = 5 V, VI = VCC Pull-downs “on”	30	70	140	μA
		VCC = 3 V, VI = VCC Pull-downs “on”	6.0	25	45	μA
IIH	“H” input current P20–P27, P40–P47, P50–P57, P60–P67, P70, P71 (Note)	VI = VCC			5.0	μA
IIH	“H” input current RESET	VI = VCC			5.0	μA
IIH	“H” input current XIN	VI = VCC		4.0		μA
IIL	“L” input current P00–P07, P10–P17, P34–P37, P40	VI = VSS			-5.0	μA
IIL	“L” input current P20–P27, P41–P47, P50–P57, P60–P67, P70, P71 (Note)	VI = VSS Pull-ups “off”			-5.0	μA
		VCC = 5 V, VI = VSS Pull-ups “on”	-30	-70	-140	μA
		VCC = 3 V, VI = VSS Pull-ups “on”	-6.0	-25	-45	μA
IIL	“L” input current RESET	VI = VSS			-5.0	μA
IIL	“L” input current XIN	VI = VSS		-4.0		μA

Note: When “1” is set to the port Xc switch bit (bit 4 at address 003B16) of CPU mode register, the drive ability of port P70 is different from the value above mentioned.

Table 41 Electrical characteristics (M version)

(VCC = 2.2 to 5.5 V, Ta = -20 to 85 °C, unless otherwise noted)

Symbol	Parameter	Test conditions	Limits			Unit
			Min.	Typ.	Max.	
VRAM	RAM retention voltage	At clock stop mode	2.0		5.5	V
ICC	Power source current	<ul style="list-style-type: none"> High-speed mode, VCC = 5 V f(XIN) = 8 MHz f(XCIN) = 32.768 kHz Output transistors "off" A-D converter in operating 		6.4	13	mA
		<ul style="list-style-type: none"> High-speed mode, VCC = 5 V f(XIN) = 8 MHz (in WIT state) f(XCIN) = 32.768 kHz Output transistors "off" A-D converter stopped 		1.6	3.2	mA
		<ul style="list-style-type: none"> Low-speed mode, VCC = 5 V, Ta ≤ 55°C f(XIN) = stopped f(XCIN) = 32.768 kHz Output transistors "off" 		25	36	μA
		<ul style="list-style-type: none"> Low-speed mode, VCC = 5 V, Ta = 25°C f(XIN) = stopped f(XCIN) = 32.768 kHz (in WIT state) Output transistors "off" 		7.0	14	μA
		<ul style="list-style-type: none"> Low-speed mode, VCC = 3 V, Ta ≤ 55°C f(XIN) = stopped f(XCIN) = 32.768 kHz Output transistors "off" 		15	22	μA
		<ul style="list-style-type: none"> Low-speed mode, VCC = 3 V, Ta = 25°C f(XIN) = stopped f(XCIN) = 32.768 kHz (in WIT state) Output transistors "off" 		4.5	9.0	μA
		All oscillation stopped (in STP state) Output transistors "off"	Ta = 25 °C Ta = 85 °C		0.1	1.0

Table 42 A-D converter characteristics (M version)

(VCC = 4.0 to 5.5 V, VSS = 0 V, Ta = -20 to 85 °C, 4 MHz ≤ f(XIN) ≤ 8 MHz, in middle/high-speed mode, unless otherwise noted)

Symbol	Parameter	Test conditions	Limits			Unit
			Min.	Typ.	Max.	
-	Resolution				8	Bits
-	Absolute accuracy (excluding quantization error)	VCC = VREF = 5V			±2	LSB
tCONV	Conversion time	f(XIN) = 8 MHz			12.5 (Note)	μs
RLADDER	Ladder resistor		12	35	100	kΩ
IVREF	Reference power source input current	VREF = 5 V	50	150	200	μA
IiA	Analog port input current				5.0	μA

Note: When an internal trigger is used in middle-speed mode, it is 14 μs.

Table 43 Timing requirements 1 (M version)

(VCC = 4.0 to 5.5 V, VSS = 0 V, Ta = -20 to 85 °C, unless otherwise noted)

Symbol	Parameter	Limits			Unit
		Min.	Typ.	Max.	
t _w (RESET)	Reset input "L" pulse width	2			μs
t _c (XIN)	Main clock input cycle time (XIN input)	125			ns
t _{wH} (XIN)	Main clock input "H" pulse width	45			ns
t _{wL} (XIN)	Main clock input "L" pulse width	40			ns
t _c (CNTR)	CNTR0, CNTR1 input cycle time	250			ns
t _{wH} (CNTR)	CNTR0, CNTR1 input "H" pulse width	105			ns
t _{wL} (CNTR)	CNTR0, CNTR1 input "L" pulse width	105			ns
t _{wH} (INT)	INT0 to INT3 input "H" pulse width	80			ns
t _{wL} (INT)	INT0 to INT3 input "L" pulse width	80			ns
t _c (SCLK)	Serial I/O clock input cycle time (Note)	800			ns
t _{wH} (SCLK)	Serial I/O clock input "H" pulse width (Note)	370			ns
t _{wL} (SCLK)	Serial I/O clock input "L" pulse width (Note)	370			ns
t _{su} (RXD-SCLK)	Serial I/O input set up time	220			ns
t _h (SCLK-RXD)	Serial I/O input hold time	100			ns

Note: When bit 6 of address 001A16 is "1" (clock synchronous).
Divide this value by four when bit 6 of address 001A16 is "0" (UART).

Table 44 Timing requirements 2 (M version)

(VCC = 2.2 to 4.0 V, VSS = 0 V, Ta = -20 to 85 °C, unless otherwise noted)

Symbol	Parameter	Limits			Unit
		Min.	Typ.	Max.	
t _w (RESET)	Reset input "L" pulse width	2			μs
t _c (XIN)	Main clock input cycle time (XIN input)	125			ns
t _{wH} (XIN)	Main clock input "H" pulse width	45			ns
t _{wL} (XIN)	Main clock input "L" pulse width	40			ns
t _c (CNTR)	CNTR0, CNTR1 input cycle time	900/(VCC-0.4)			ns
t _{wH} (CNTR)	CNTR0, CNTR1 input "H" pulse width	450/(VCC-0.4)-20			ns
t _{wL} (CNTR)	CNTR0, CNTR1 input "L" pulse width	450/(VCC-0.4)-20			ns
t _{wH} (INT)	INT0 to INT3 input "H" pulse width	230			ns
t _{wL} (INT)	INT0 to INT3 input "L" pulse width	230			ns
t _c (SCLK)	Serial I/O clock input cycle time (Note)	2000			ns
t _{wH} (SCLK)	Serial I/O clock input "H" pulse width (Note)	950			ns
t _{wL} (SCLK)	Serial I/O clock input "L" pulse width (Note)	950			ns
t _{su} (RXD-SCLK)	Serial I/O input set up time	400			ns
t _h (SCLK-RXD)	Serial I/O input hold time	200			ns

Note: When bit 6 of address 001A16 is "1" (clock synchronous).
Divide this value by four when bit 6 of address 001A16 is "0" (UART).

Table 45 Switching characteristics 1 (M version)

(VCC = 4.0 to 5.5 V, VSS = 0 V, Ta = -20 to 85 °C, unless otherwise noted)

Symbol	Parameter	Limits			Unit
		Min.	Typ.	Max.	
twH(SCLK)	Serial I/O clock output "H" pulse width	tc (SCLK)/2-30			ns
twL(SCLK)	Serial I/O clock output "L" pulse width	tc (SCLK)/2-30			ns
td(SCLK-TxD)	Serial I/O output delay time (Note 1)			140	ns
tv(SCLK-TxD)	Serial I/O output valid time (Note 1)	-30			ns
tr(SCLK)	Serial I/O clock output rising time			30	ns
tf(SCLK)	Serial I/O clock output falling time			30	ns
tr(CMOS)	CMOS output rising time (Note 2)		10	30	ns
tf(CMOS)	CMOS output falling time (Note 2)		10	30	ns

Notes 1: When the P45/TxD P-channel output disable bit of the UART control register (bit 4 of address 001B16) is "0".

2: XOUT and XCOUNT pins are excluded.

Table 46 Switching characteristics 2 (M version)

(VCC = 2.2 to 4.0 V, VSS = 0 V, Ta = -20 to 85 °C, unless otherwise noted)

Symbol	Parameter	Limits			Unit
		Min.	Typ.	Max.	
twH(SCLK)	Serial I/O clock output "H" pulse width	tc (SCLK)/2-50			ns
twL(SCLK)	Serial I/O clock output "L" pulse width	tc (SCLK)/2-50			ns
td(SCLK-TxD)	Serial I/O output delay time (Note 1)			350	ns
tv(SCLK-TxD)	Serial I/O output valid time (Note 1)	-30			ns
tr(SCLK)	Serial I/O clock output rising time			50	ns
tf(SCLK)	Serial I/O clock output falling time			50	ns
tr(CMOS)	CMOS output rising time (Note 2)		20	50	ns
tf(CMOS)	CMOS output falling time (Note 2)		20	50	ns

Notes 1: When the P45/TxD P-channel output disable bit of the UART control register (bit 4 of address 001B16) is "0".

2: XOUT and XCOUNT pins are excluded.

Table 47 Absolute maximum ratings (H version)

Symbol	Parameter	Conditions	Ratings	Unit
VCC	Power source voltage	All voltages are based on Vss. Output transistors are cut off.	-0.3 to 6.5	V
Vi	Input voltage P00-P07, P10-P17, P20-P27, P34-P37, P40-P47, P50-P57 P60-P67, P70, P71		-0.3 to VCC +0.3	V
Vi	Input voltage VL1		-0.3 to VL2	V
Vi	Input voltage VL2		VL1 to VL3	V
Vi	Input voltage VL3		VL2 to VCC +0.3	V
Vi	Input voltage RESET, XIN		-0.3 to VCC +0.3	V
Vo	Output voltage P00-P07, P10-P17		At output port	-0.3 to VCC +0.3
		At segment output	-0.3 to VL3	V
Vo	Output voltage P34-P37	At segment output	-0.3 to VL3	V
Vo	Output voltage P20-P27, P41-P47, P50-P57, P60-P67, P70, P71		-0.3 to VCC +0.3	V
Vo	Output voltage SEG0-SEG11		-0.3 to VL3	V
Vo	Output voltage XOUT		-0.3 to VCC +0.3	V
Pd	Power dissipation	Ta = 25°C	300	mW
Topr	Operating temperature		-20 to 85	°C
Tstg	Storage temperature		-40 to 150	°C

Table 48 Recommended operating conditions (H version)

(VCC = 2.0 to 5.5 V, Ta = -20 to 85 °C, unless otherwise noted)

Symbol	Parameter		Limits			Unit
			Min.	Typ.	Max.	
VCC	Power source voltage	High-speed mode f(XIN) = 8 MHz	4.0	5.0	5.5	V
		Middle-speed mode f(XIN) = 8 MHz	2.0	5.0	5.5	
		Low-speed mode	2.0	5.0	5.5	
VSS	Power source voltage			0		V
VREF	A-D conversion reference voltage		2.0		VCC	V
AVSS	Analog power source voltage			0		V
VIA	Analog input voltage AN0-AN7		AVSS		VCC	V
VIH	"H" input voltage	P00-P07, P10-P17, P34-P37, P40, P41, P45, P47, P52, P53, P56, P60-P67, P70, P71 (CM4= 0)	0.7VCC		VCC	V
VIH	"H" input voltage	P20-P27, P42-P44, P46, P50, P51, P54, P55, P57	0.8VCC		VCC	V
VIH	"H" input voltage	RESET	0.8VCC		VCC	V
VIH	"H" input voltage	XIN	0.8VCC		VCC	V
VIL	"L" input voltage	P00-P07, P10-P17, P34-P37, P40, P41, P45, P47, P52, P53, P56, P60-P67, P70, P71 (CM4= 0)	0		0.3 VCC	V
VIL	"L" input voltage	P20-P27, P42-P44, P46, P50, P51, P54, P55, P57	0		0.2 VCC	V
VIL	"L" input voltage	RESET	0		0.2 VCC	V
VIL	"L" input voltage	XIN	0		0.2 VCC	V

Table 49 Recommended operating conditions (H version)

(VCC = 2.0 to 5.5 V, Ta = -20 to 85°C, unless otherwise noted)

Symbol	Parameter	Limits			Unit
		Min.	Typ.	Max.	
$\Sigma I_{OH(peak)}$	"H" total peak output current P00-P07, P10-P17, P20-P27 (Note 1)			-40	mA
$\Sigma I_{OH(peak)}$	"H" total peak output current P41-P47, P50-P57, P60-P67, P70, P71 (Note 1)			-40	mA
$\Sigma I_{OL(peak)}$	"L" total peak output current P00-P07, P10-P17, P20-P27 (Note 1)			40	mA
$\Sigma I_{OL(peak)}$	"L" total peak output current P41-P47, P50-P57, P60-P67, P70, P71 (Note 1)			40	mA
$\Sigma I_{OH(avg)}$	"H" total average output current P00-P07, P10-P17, P20-P27 (Note 1)			-20	mA
$\Sigma I_{OH(avg)}$	"H" total average output current P41-P47, P50-P57, P60-P67, P70, P71 (Note 1)			-20	mA
$\Sigma I_{OL(avg)}$	"L" total average output current P00-P07, P10-P17, P20-P27 (Note 1)			20	mA
$\Sigma I_{OL(avg)}$	"L" total average output current P41-P47, P50-P57, P60-P67, P70, P71 (Note 1)			20	mA
$I_{OH(peak)}$	"H" peak output current P00-P07, P10-P17 (Note 2)			-2	mA
$I_{OH(peak)}$	"H" peak output current P20-P27, P41-P47, P50-P57, P60-P67, P70, P71 (Note 2)			-5	mA
$I_{OL(peak)}$	"L" peak output current P00-P07, P10-P17 (Note 2)			5	mA
$I_{OL(peak)}$	"L" peak output current P20-P27, P41-P47, P50-P57, P60-P67, P70, P71 (Note 2)			10	mA
$I_{OH(avg)}$	"H" average output current P00-P07, P10-P17 (Note 3)			-1.0	mA
$I_{OH(avg)}$	"H" average output current P20-P27, P41-P47, P50-P57, P60-P67, P70, P71 (Note 3)			-2.5	mA
$I_{OL(avg)}$	"L" average output current P00-P07, P10-P17 (Note 3)			2.5	mA
$I_{OL(avg)}$	"L" average output current P20-P27, P41-P47, P50-P57, P60-P67, P70, P71 (Note 3)			5.0	mA
$f(CNTR_0)$ $f(CNTR_1)$	Input frequency for timers X and Y (duty cycle 50%)	(4.0 V ≤ VCC ≤ 5.5 V)		4.0	MHz
		(2.0 V ≤ VCC ≤ 4.0 V)		VCC	MHz
$f(XIN)$	Main clock input oscillation frequency (Note 4)	High-speed mode (4.0 V ≤ VCC ≤ 5.5 V)		8.0	MHz
		High-speed mode (2.0 V ≤ VCC ≤ 4.0 V)		2XVCC	MHz
		Middle-speed mode		8.0	MHz
$f(XCIN)$	Sub-clock input oscillation frequency (Notes 4, 5)		32.768	50	kHz

Notes 1: The total output current is the sum of all the currents flowing through all the applicable ports. The total average current is an average value measured over 100 ms. The total peak current is the peak value of all the currents.

2: The peak output current is the peak current flowing in each port.

3: The average output current is an average value measured over 100 ms.

4: When the oscillation frequency has a duty cycle of 50 %.

5: When using the microcomputer in low-speed mode, make sure that the sub-clock input oscillation frequency on condition that $f(XCIN) < f(XIN)/3$.

Table 50 Electrical characteristics (H version)
(VCC = 4.0 to 5.5 V, Ta = -20 to 85 °C, unless otherwise noted)

Symbol	Parameter	Test conditions	Limits			Unit
			Min.	Typ.	Max.	
VOH	“H” output voltage P00–P07, P10–P17	IOH = -2.5 mA	VCC-2.0			V
		IOH = -0.6 mA VCC = 2.5 V	VCC-1.0			V
VOH	“H” output voltage P20–P27, P41–P47, P50–P57, P60–P67, P70, P71 (Note)	IOH = -5 mA	VCC-2.0			V
		IOH = -1.25 mA	VCC-0.5			V
		IOH = -1.25 mA VCC = 2.5 V	VCC-1.0			V
VOL	“L” output voltage P00–P07, P10–P17	IOI = 5 mA			2.0	V
		IOI = 1.25 mA			0.5	V
		IOI = 1.25 mA VCC = 2.5 V			1.0	V
VOL	“L” output voltage P20–P27, P41–P47, P50–P57, P60–P67, P70, P71 (Note)	IOI = 10 mA			2.0	V
		IOI = 2.5 mA			0.5	V
		IOI = 2.5 mA VCC = 2.5 V			1.0	V
VT+ – VT-	Hysteresis INT0–INT3, ADT, CNTR0, CNTR1, P20–P27			0.5		V
VT+ – VT-	Hysteresis SCLK, RxD			0.5		V
VT+ – VT-	Hysteresis RESET	RESET : VCC = 2.0 V to 5.5 V		0.5		V
IIH	“H” input current P00–P07, P10–P17, P34–P37	VI = VCC Pull-downs “off”			5.0	μA
		VCC = 5 V, VI = VCC Pull-downs “on”	30	70	140	μA
		VCC = 3 V, VI = VCC Pull-downs “on”	6.0	25	45	μA
IIH	“H” input current P20–P27, P40–P47, P50–P57, P60–P67, P70, P71 (Note)	VI = VCC			5.0	μA
IIH	“H” input current RESET	VI = VCC			5.0	μA
IIH	“H” input current XIN	VI = VCC		4.0		μA
IIL	“L” input current P00–P07, P10–P17, P34–P37, P40	VI = VSS			-5.0	μA
IIL	“L” input current P20–P27, P41–P47, P50–P57, P60–P67, P70, P71 (Note)	VI = VSS Pull-ups “off”			-5.0	μA
		VCC = 5 V, VI = VSS Pull-ups “on”	-30	-70	-140	μA
		VCC = 3 V, VI = VSS Pull-ups “on”	-6.0	-25	-45	μA
IIL	“L” input current RESET	VI = VSS			5.0	μA
IIL	“L” input current XIN	VI = VSS		-4.0		μA

Note: When “1” is set to the port Xc switch bit (bit 4 at address 003B16) of CPU mode register, the drive ability of port P70 is different from the value above mentioned.

Table 51 Electrical characteristics (H version)

(VCC = 2.0 to 5.5 V, Ta = -20 to 85 °C, unless otherwise noted)

Symbol	Parameter	Test conditions	Limits			Unit
			Min.	Typ.	Max.	
VRAM	RAM retention voltage	At clock stop mode	2.0		5.5	V
ICC	Power source current	<ul style="list-style-type: none"> High-speed mode, VCC = 5 V f(XIN) = 8 MHz f(XCIN) = 32.768 kHz Output transistors "off" A-D converter in operating 		6.4	13	mA
		<ul style="list-style-type: none"> High-speed mode, VCC = 5 V f(XIN) = 8 MHz (in WIT state) f(XCIN) = 32.768 kHz Output transistors "off" A-D converter stopped 		1.6	3.2	mA
		<ul style="list-style-type: none"> Low-speed mode, VCC = 5 V, Ta ≤ 55°C f(XIN) = stopped f(XCIN) = 32.768 kHz Output transistors "off" 		25	36	μA
		<ul style="list-style-type: none"> Low-speed mode, VCC = 5 V, Ta = 25°C f(XIN) = stopped f(XCIN) = 32.768 kHz (in WIT state) Output transistors "off" 		7.0	14	μA
		<ul style="list-style-type: none"> Low-speed mode, VCC = 3 V, Ta ≤ 55°C f(XIN) = stopped f(XCIN) = 32.768 kHz Output transistors "off" 		15	22	μA
		<ul style="list-style-type: none"> Low-speed mode, VCC = 3 V, Ta = 25°C f(XIN) = stopped f(XCIN) = 32.768 kHz (in WIT state) Output transistors "off" 		4.5	9.0	μA
		All oscillation stopped (in STP state) Output transistors "off"	Ta = 25 °C Ta = 85 °C		0.1	1.0

Table 52 A-D converter characteristics (H version)

(VCC = 2.2 to 5.5 V, VSS = AVSS = 0 V, Ta = -20 to 85 °C, 4 MHz ≤ f(XIN) ≤ 8 MHz, in middle/high-speed mode unless otherwise noted)

Symbol	Parameter	Test conditions	Limits			Unit
			Min.	Typ.	Max.	
-	Resolution				8	Bits
-	Absolute accuracy (excluding quantization error)	VCC = VREF = 4.0 V to 5.5 V f(XIN) = 8 MHz VCC = VREF = 2.2 V to 4.0V f(XIN) = 2 × VCC MHz			±2	LSB
tCONV	Conversion time	f(XIN) = 8 MHz			12.5 (Note)	μs
RLADDER	Ladder resistor		12	35	100	kΩ
IVREF	Reference power source input current	VREF = 5 V	50	150	200	μA
I _{IA}	Analog port input current				5.0	μA

Note: When an internal trigger is used in middle-speed mode, it is 14 μs.

Table 53 Timing requirements 1 (H version)

(VCC = 4.0 to 5.5 V, VSS = 0 V, Ta = -20 to 85 °C, unless otherwise noted)

Symbol	Parameter	Limits			Unit
		Min.	Typ.	Max.	
t _w (RESET)	Reset input "L" pulse width	2			μs
t _c (XIN)	Main clock input cycle time (XIN input)	125			ns
t _{wH} (XIN)	Main clock input "H" pulse width	45			ns
t _{wL} (XIN)	Main clock input "L" pulse width	40			ns
t _c (CNTR)	CNTR0, CNTR1 input cycle time	250			ns
t _{wH} (CNTR)	CNTR0, CNTR1 input "H" pulse width	105			ns
t _{wL} (CNTR)	CNTR0, CNTR1 input "L" pulse width	105			ns
t _{wH} (INT)	INT0 to INT3 input "H" pulse width	80			ns
t _{wL} (INT)	INT0 to INT3 input "L" pulse width	80			ns
t _c (SCLK)	Serial I/O clock input cycle time (Note)	800			ns
t _{wH} (SCLK)	Serial I/O clock input "H" pulse width (Note)	370			ns
t _{wL} (SCLK)	Serial I/O clock input "L" pulse width (Note)	370			ns
t _{su} (RXD-SCLK)	Serial I/O input set up time	220			ns
t _h (SCLK-RXD)	Serial I/O input hold time	100			ns

Note: When bit 6 of address 001A16 is "1" (clock synchronous).
Divide this value by four when bit 6 of address 001A16 is "0" (UART).

Table 54 Timing requirements 2 (H version)

(VCC = 2.0 to 4.0 V, VSS = 0 V, Ta = -20 to 85 °C, unless otherwise noted)

Symbol	Parameter	Limits			Unit
		Min.	Typ.	Max.	
t _w (RESET)	Reset input "L" pulse width	2			μs
t _c (XIN)	Main clock input cycle time (XIN input)	125			ns
t _{wH} (XIN)	Main clock input "H" pulse width	45			ns
t _{wL} (XIN)	Main clock input "L" pulse width	40			ns
t _c (CNTR)	CNTR0, CNTR1 input cycle time	900/(VCC-0.4)			ns
t _{wH} (CNTR)	CNTR0, CNTR1 input "H" pulse width	450/(VCC-0.4)-20			ns
t _{wL} (CNTR)	CNTR0, CNTR1 input "L" pulse width	450/(VCC-0.4)-20			ns
t _{wH} (INT)	INT0 to INT3 input "H" pulse width	230			ns
t _{wL} (INT)	INT0 to INT3 input "L" pulse width	230			ns
t _c (SCLK)	Serial I/O clock input cycle time (Note)	2000			ns
t _{wH} (SCLK)	Serial I/O clock input "H" pulse width (Note)	950			ns
t _{wL} (SCLK)	Serial I/O clock input "L" pulse width (Note)	950			ns
t _{su} (RXD-SCLK)	Serial I/O input set up time	400			ns
t _h (SCLK-RXD)	Serial I/O input hold time	200			ns

Note: When bit 6 of address 001A16 is "1" (clock synchronous).
Divide this value by four when bit 6 of address 001A16 is "0" (UART).

Table 55 Switching characteristics 1 (H version)

(VCC = 4.0 to 5.5 V, VSS = 0 V, Ta = -20 to 85 °C, unless otherwise noted)

Symbol	Parameter	Limits			Unit
		Min.	Typ.	Max.	
twH(SCLK)	Serial I/O clock output "H" pulse width	tc (SCLK)/2-30			ns
twL(SCLK)	Serial I/O clock output "L" pulse width	tc (SCLK)/2-30			ns
td(SCLK-TxD)	Serial I/O output delay time (Note 1)			140	ns
tV(SCLK-TxD)	Serial I/O output valid time (Note 1)	-30			ns
tr(SCLK)	Serial I/O clock output rising time			30	ns
tf(SCLK)	Serial I/O clock output falling time			30	ns
tr(CMOS)	CMOS output rising time (Note 2)		10	30	ns
tf(CMOS)	CMOS output falling time (Note 2)		10	30	ns

Notes1: When the P45/TxD P-channel output disable bit of the UART control register (bit 4 of address 001B16) is "0".

2: XOUT and Xcout pins are excluded.

Table 56 Switching characteristics 2 (H version)

(VCC = 2.0 to 4.0 V, VSS = 0 V, Ta = -20 to 85 °C, unless otherwise noted)

Symbol	Parameter	Limits			Unit
		Min.	Typ.	Max.	
twH(SCLK)	Serial I/O clock output "H" pulse width	tc (SCLK)/2-50			ns
twL(SCLK)	Serial I/O clock output "L" pulse width	tc (SCLK)/2-50			ns
td(SCLK-TxD)	Serial I/O output delay time (Note 1)			350	ns
tV(SCLK-TxD)	Serial I/O output valid time (Note 1)	-30			ns
tr(SCLK)	Serial I/O clock output rising time			50	ns
tf(SCLK)	Serial I/O clock output falling time			50	ns
tr(CMOS)	CMOS output rising time (Note 2)		20	50	ns
tf(CMOS)	CMOS output falling time (Note 2)		20	50	ns

Notes1: When the P45/TxD P-channel output disable bit of the UART control register (bit 4 of address 001B16) is "0".

2: XOUT and Xcout pins are excluded.

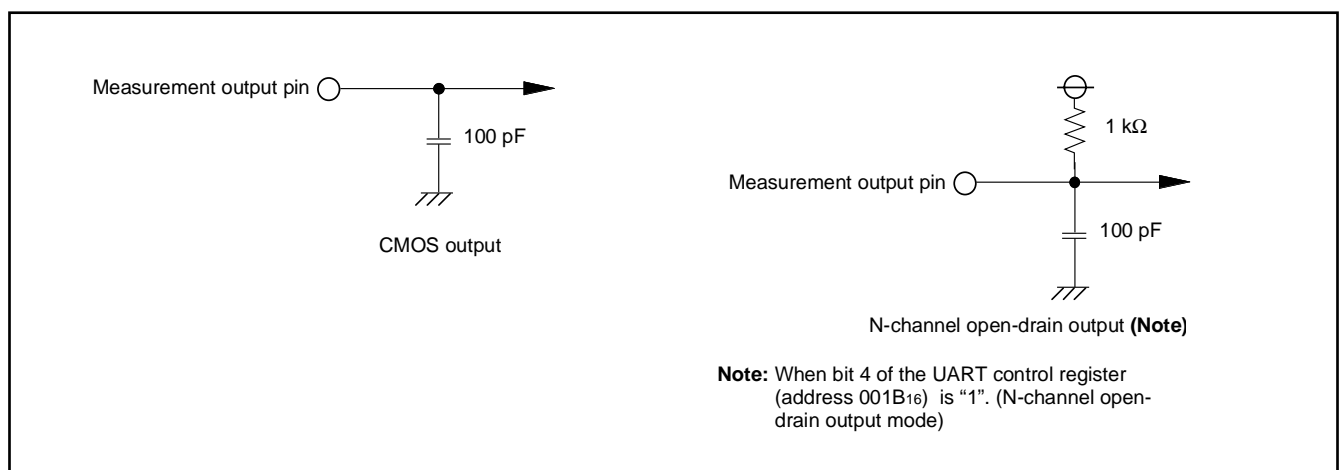

Fig. 47 Circuit for measuring output switching characteristics

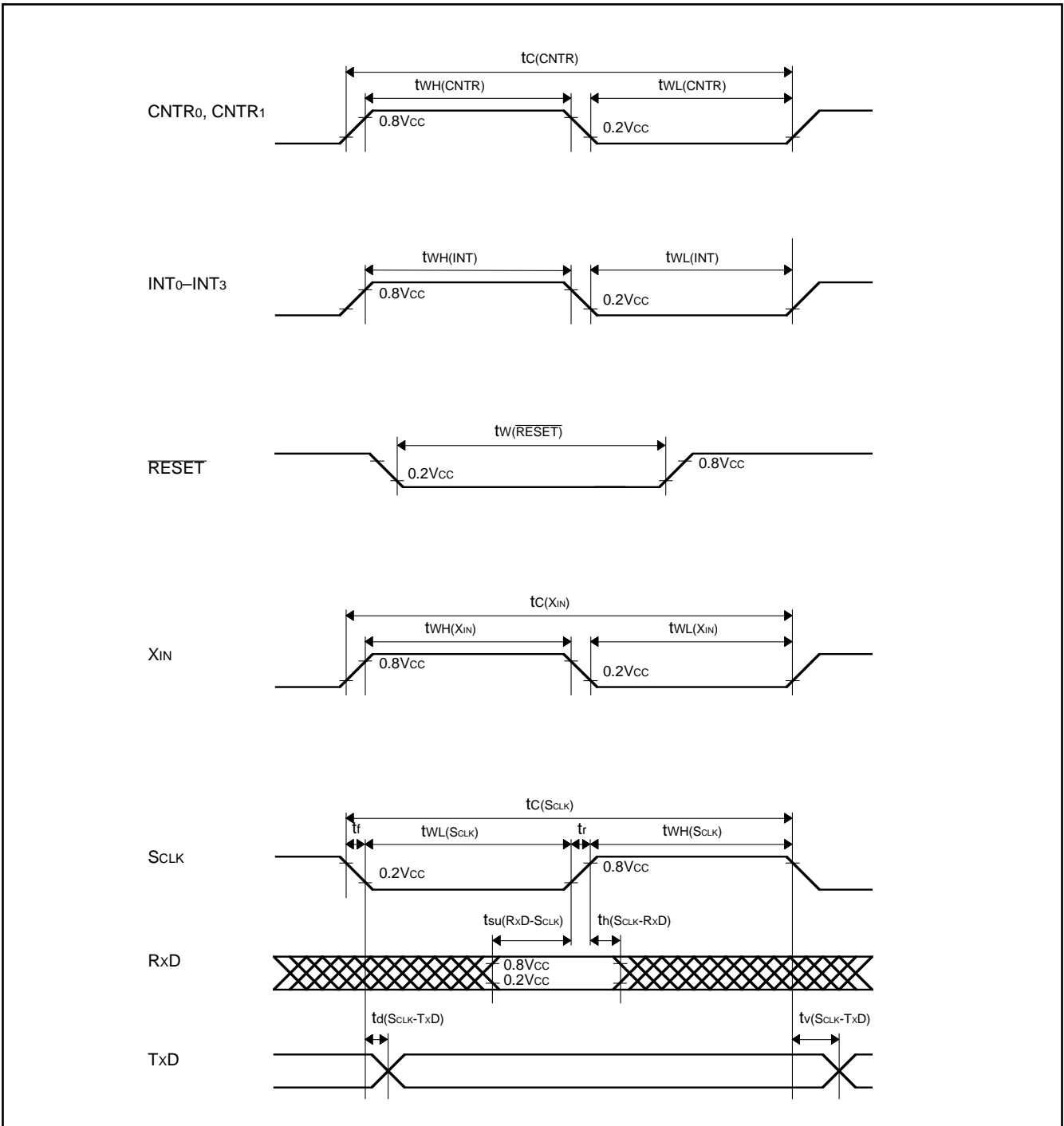

Fig. 48 Timing diagram

PACKAGE OUTLINE

80P6N-A (MMP)

Plastic 80pin 14X20mm body QFP

EIAJ Package Code	JEDEC Code	Weight(g)	Lead Material
QFP80-P-1420-0.80	-	1.58	Alloy 42

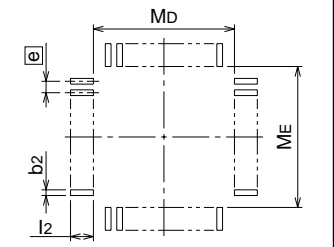
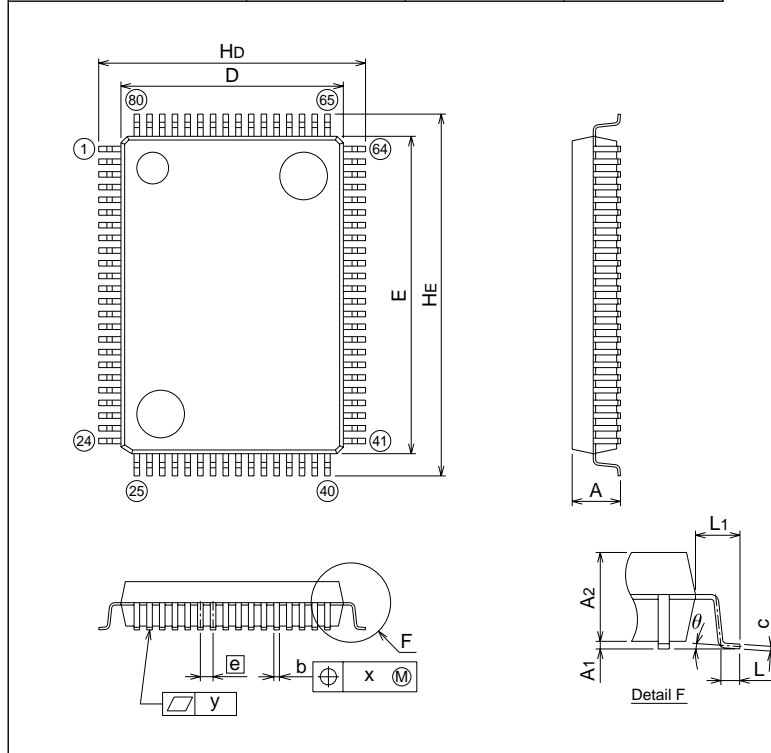

Recommended Mount Pad

Symbol	Dimension in Millimeters		
	Min	Nom	Max
A	-	-	3.05
A1	0	0.1	0.2
A2	-	2.8	-
b	0.3	0.35	0.45
c	0.13	0.15	0.2
D	13.8	14.0	14.2
E	19.8	20.0	20.2
e	-	0.8	-
Hd	16.5	16.8	17.1
HE	22.5	22.8	23.1
L	0.4	0.6	0.8
L1	-	1.4	-
x	-	-	0.2
y	-	-	0.1
theta	0°	-	10°
b2	-	0.5	-
l2	1.3	-	-
MD	-	14.6	-
ME	-	20.6	-

80P6S-A (MMP)

Plastic 80pin 14X14mm body QFP

EIAJ Package Code	JEDEC Code	Weight(g)	Lead Material
QFP80-P-1414-0.65	-	1.11	Alloy 42

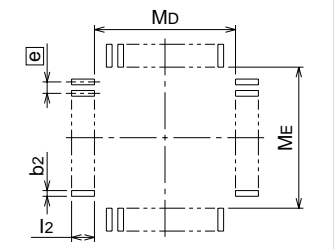
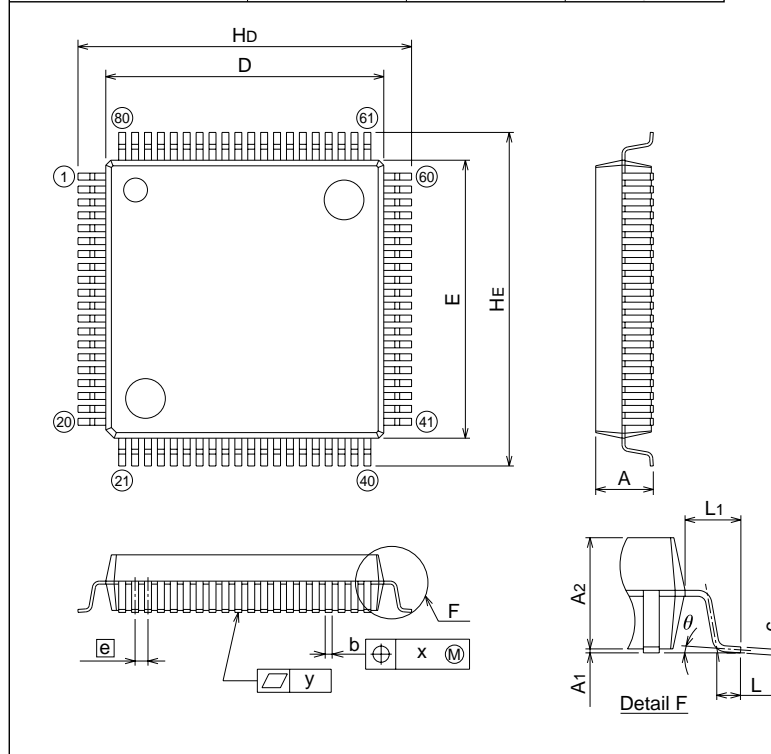

Recommended Mount Pad

Symbol	Dimension in Millimeters		
	Min	Nom	Max
A	-	-	3.05
A1	0	0.1	0.2
A2	-	2.8	-
b	0.25	0.3	0.4
c	0.13	0.15	0.2
D	13.8	14.0	14.2
E	13.8	14.0	14.2
e	-	0.65	-
Hd	16.5	16.8	17.1
HE	16.5	16.8	17.1
L	0.4	0.6	0.8
L1	-	1.4	-
x	-	-	0.13
y	-	-	0.1
theta	0°	-	10°
b2	-	0.35	-
l2	1.3	-	-
MD	-	14.6	-
ME	-	14.6	-

80P6Q-A

(MMP)

Plastic 80pin 12X12mm body LQFP

EIAJ Package Code	JEDEC Code	Weight(g)	Lead Material
LQFP80-P-1212-0.5	-	0.47	Cu Alloy

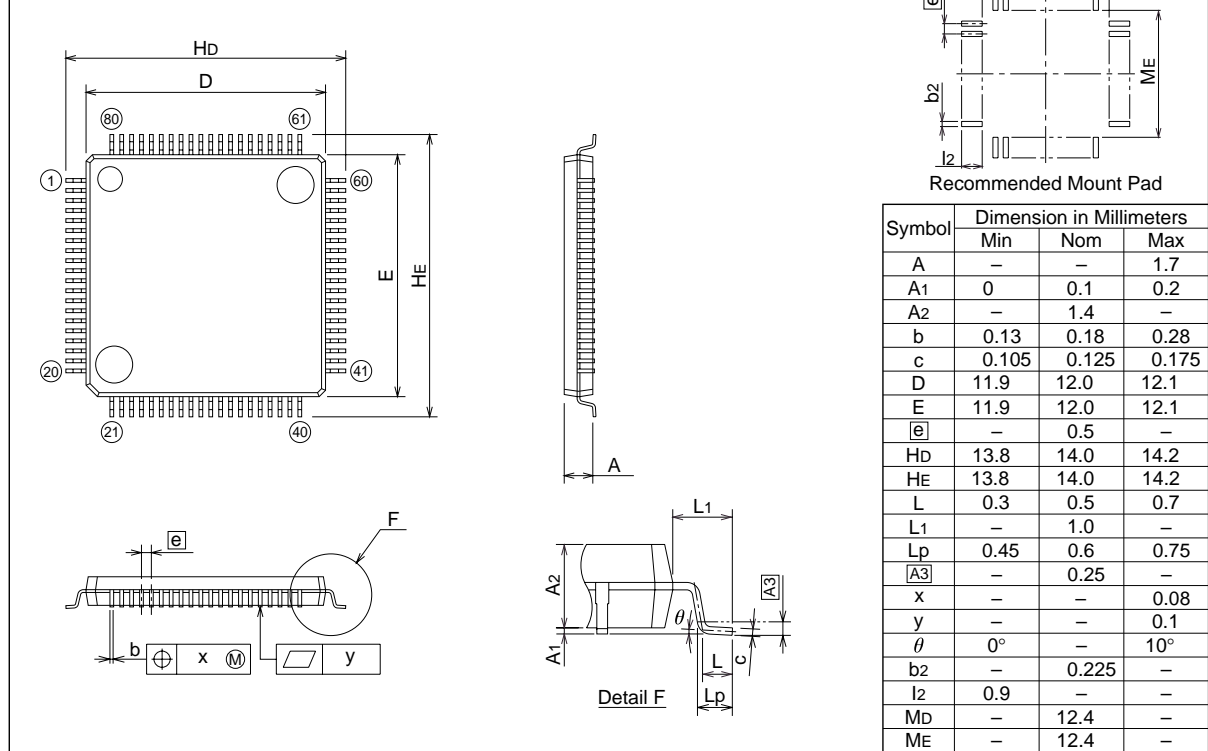

Symbol	Dimension in Millimeters		
	Min	Nom	Max
A	-	-	1.7
A1	0	0.1	0.2
A2	-	1.4	-
b	0.13	0.18	0.28
c	0.105	0.125	0.175
D	11.9	12.0	12.1
E	11.9	12.0	12.1
e	-	0.5	-
HD	13.8	14.0	14.2
HE	13.8	14.0	14.2
L	0.3	0.5	0.7
L1	-	1.0	-
Lp	0.45	0.6	0.75
A3	-	0.25	-
x	-	-	0.08
y	-	-	0.1
θ	0°	-	10°
b2	-	0.225	-
l2	0.9	-	-
MD	-	12.4	-
ME	-	12.4	-



MITSUBISHI ELECTRIC CORPORATION
HEAD OFFICE: 2-2-3, MARUNOUCHI, CHIYODA-KU, TOKYO 100-8310, JAPAN

Keep safety first in your circuit designs!

- Mitsubishi Electric Corporation puts the maximum effort into making semiconductor products better and more reliable, but there is always the possibility that trouble may occur with them. Trouble with semiconductors may lead to personal injury, fire or property damage. Remember to give due consideration to safety when making your circuit designs, with appropriate measures such as (i) placement of substitutive, auxiliary circuits, (ii) use of non-flammable material or (iii) prevention against any malfunction or mishap.

Notes regarding these materials

- These materials are intended as a reference to assist our customers in the selection of the Mitsubishi semiconductor product best suited to the customer's application; they do not convey any license under any intellectual property rights, or any other rights, belonging to Mitsubishi Electric Corporation or a third party.
- Mitsubishi Electric Corporation assumes no responsibility for any damage, or infringement of any third-party's rights, originating in the use of any product data, diagrams, charts, programs, algorithms, or circuit application examples contained in these materials.
- All information contained in these materials, including product data, diagrams, charts, programs and algorithms represents information on products at the time of publication of these materials, and are subject to change by Mitsubishi Electric Corporation without notice due to product improvements or other reasons. It is therefore recommended that customers contact Mitsubishi Electric Corporation or an authorized Mitsubishi Semiconductor product distributor for the latest product information before purchasing a product listed herein. The information described here may contain technical inaccuracies or typographical errors. Mitsubishi Electric Corporation assumes no responsibility for any damage, liability, or other loss rising from these inaccuracies or errors. Please also pay attention to information published by Mitsubishi Electric Corporation by various means, including the Mitsubishi Semiconductor home page (<http://www.mitsubishichips.com>).
- When using any or all of the information contained in these materials, including product data, diagrams, charts, programs, and algorithms, please be sure to evaluate all information as a total system before making a final decision on the applicability of the information and products. Mitsubishi Electric Corporation assumes no responsibility for any damage, liability or other loss resulting from the information contained herein.
- Mitsubishi Electric Corporation semiconductors are not designed or manufactured for use in a device or system that is used under circumstances in which human life is potentially at stake. Please contact Mitsubishi Electric Corporation or an authorized Mitsubishi Semiconductor product distributor when considering the use of a product contained herein for any specific purposes, such as apparatus or systems for transportation, vehicular, medical, aerospace, nuclear, or undersea repeater use.
- The prior written approval of Mitsubishi Electric Corporation is necessary to reprint or reproduce in whole or in part these materials.
- If these products or technologies are subject to the Japanese export control restrictions, they must be exported under a license from the Japanese government and cannot be imported into a country other than the approved destination. Any diversion or reexport contrary to the export control laws and regulations of Japan and/or the country of destination is prohibited.
- Please contact Mitsubishi Electric Corporation or an authorized Mitsubishi Semiconductor product distributor for further details on these materials or the products contained therein.

REVISION HISTORY

3822 GROUP DATA SHEET

Rev.	Date	Description	
		Page	Summary
1.0	01/20/98		First Edition
2.0	10/23/00	1	“●Memory size” of “FEATURES” is partly revised.
		1	“●Serial I/O” of “FEATURES” is partly revised.
		1	“●A-D converter” of “FEATURES” is added.
		1	“●2 clock generating circuits” of “FEATURES” is partly revised.
		1	“●Power source voltage” of “FEATURES” is partly revised.
		1	“●Power dissipation” of “FEATURES” is partly added.
		1	Product name into Figure 1 is revised.
		2	Product name into Figure 2 is revised.
		3	Figure 3 is partly revised.
		4	“Function” of “Vcc, Vss” into Table 1 is partly revised.
		5	“Function except a port function” into Table 2 is partly revised.
		6	Figure 4 is partly revised.
		7	Explanations of “GROUP EXPANSION (STANDARD, ONE TIME PROM VERSION, EPROM VERSION)” are partly revised.
		7	Figure 5 is partly revised.
		7	Table 3 is partly revised.
		8	Explanations of “GROUP EXPANSION (EXTENDED OPERATING TEMPERATURE VERSION)” are partly revised.
		8	Figure 6 is partly revised.
		8	Table 4 is partly revised.
		9	“GROUP EXPANSION (M VERSION)” is added.
		9	Figure 7 is added.
		9	Table 5 is added.
		10	“GROUP EXPANSION (H VERSION)” is added.
		10	Figure 8 is added.
		10	Table 6 is added.
		11–13	Explanations of “CENTRAL PROCESSING UNIT (CPU)” are added.
		11	Figure 9 is added.
		12	Figure 10 is added.
		12	Table 7 is added.
		13	Table 8 is added.
		15	Figure 12 is partly revised.
		17	Figure 14 is partly revised.
		18	Table 9 is partly revised.
		21	Figure 17 is partly revised.
		22	Explanations of “Interrupt Control” is partly added.
22	Explanations of “Interrupt Operation” is partly revised.		
22	Explanations of “■Notes” are partly revised.		
22	Table 9 is partly revised.		
24	Explanations of “Key Input Interrupt (Key-on wake up)” are partly revised.		
25	Figure 21 is partly revised.		
26	Explanations of “●Timer X write control” are partly revised.		
26	Explanations of “●Real time port control” are partly revised.		
29	Figure 25 is partly revised.		
30	Figure 27 is partly revised.		
32	Figure 29 is partly revised.		
33	Explanations of “[Channel Selector]” are partly added.		
33	Explanations of “[Comparator and Control Circuit]” are partly added.		
34	Figure 32 is partly revised.		

REVISION HISTORY

3822 GROUP DATA SHEET

Rev.	Date	Description	
		Page	Summary
2.0	10/23/00	35 40 41 41 43 46 47 47 50 52 52 52 52 52 52 54-72 74, 75	Figure 33 is partly revised. Explanations of "φ CLOCK SYSTEM OUTPUT FUNCTION" are partly revised. Explanations of "RESET CIRCUIT" are partly revised. Figure 39 is partly revised. Explanations of "CLOCK GENERATING CIRCUIT" are partly eliminated. Explanations of "Decimal Calculations" are partly eliminated. Explanations of "DATA REQUIRED FOR MASK ORDERS" are partly added. Table 14 is partly revised. Test conditions of IIL of P00-P07, P10-P17, P34-P37, P40 is added. Limit of tC(CNTR) into Table 21 is revised. Limit of tWH(CNTR) into Table 21 is revised. Limit of tWL(CNTR) into Table 21 is revised. Limit of tC(CNTR) into Table 22 is revised. Limit of tWH(CNTR) into Table 22 is revised. Limit of tWL(CNTR) into Table 22 is revised. Tables 25 to 56 are added. "PACKAGE OUTLINE" is added.
2.1	01/31/01	13 21 22 25 31 44 47	Explanations of "•Bit 3: Decimal mode flag (D)" are partly added. Figure 17 is partly revised. Explanations of "■Notes on interrupts" are revised. Figure 21 is partly revised. "■Notes on serial I/O" is added. Figure 44 is partly revised. Explanations of "DATA REQUIRED FOR MASK ORDERS" are partly revised.