

SURFACE MOUNT DEVICES

OPERATING AND STORAGE TEMPERATURE -65°C to +175°C

TYPE	Maximum Peak Reverse Voltage	Maximum Average Rectified Current @ Half-Wave Resistive Load 60Hz		Maximum Forward Peak Surge Current @8.3ms Superimposed	Maximum Reverse Current @ PRV @ 25°C TA	Maximum Forward Voltage @ 25°C TA		Maximum Reverse Recovery Time
	PRV	I _o @ Tc*		IFM (Surge)	IR	IFM	VFM	T _{rr}
	VPK	AAV	°C	APK	μA _{dc}	APK	VPK	nS

1.0 AMPERES-GLASS PASSIVATED/GS-1



GS11	50	1.0	75	30	5.0	1.0	1.1	-
GS12	100	1.0	75	30	5.0	1.0	1.1	-
GS13	200	1.0	75	30	5.0	1.0	1.1	-
GS14	400	1.0	75	30	5.0	1.0	1.1	-
GS15	600	1.0	75	30	5.0	1.0	1.1	-
GS16	800	1.0	75	30	5.0	1.0	1.1	-
GS17	1000	1.0	75	30	5.0	1.0	1.1	-

1.0 AMPERES-GLASS PASSIVATED/JS-1



JS11	50	1.0	75	30	5.0	1.0	1.1	-
JS12	100	1.0	75	30	5.0	1.0	1.1	-
JS13	200	1.0	75	30	5.0	1.0	1.1	-
JS14	400	1.0	75	30	5.0	1.0	1.1	-
JS15	600	1.0	75	30	5.0	1.0	1.1	-
JS16	800	1.0	75	30	5.0	1.0	1.1	-
JS17	1000	1.0	75	30	5.0	1.0	1.1	-

1.0 AMPERES-FAST RECOVERY/GS-1



FGS101	50	1.0	55	30	5.0	1.0	1.3	150
FGS102	100	1.0	55	30	5.0	1.0	1.3	150
FGS103	200	1.0	55	30	5.0	1.0	1.3	150
FGS104	400	1.0	55	30	5.0	1.0	1.3	150
FGS105	600	1.0	55	30	5.0	1.0	1.3	250
FGS106	800	1.0	55	30	5.0	1.0	1.3	500
FGS107	1000	1.0	55	30	5.0	1.0	1.3	500

1.0 AMPERES-FAST RECOVERY/JS-1



FJS101	50	1.0	55	30	5.0	1.0	1.3	150
FJS102	100	1.0	55	30	5.0	1.0	1.3	150
FJS103	200	1.0	55	30	5.0	1.0	1.3	150
FJS104	400	1.0	55	30	5.0	1.0	1.3	150
FJS105	600	1.0	55	30	5.0	1.0	1.3	250
FJS106	800	1.0	55	30	5.0	1.0	1.3	500
FJS107	1000	1.0	55	30	5.0	1.0	1.3	500

AXIAL LEAD TAPING SPECIFICATIONS FOR RECTIFIERS

T-91-20

29E D ■ 7452808 0000032 T ■

QUA-TRON ELECTRONICS

Axial lead devices are packed in accordance with EIA standard RS-296-D and specifications given below.

COMPONENT OUTLINE	COMPONENT PITCH A	INNER TAPE PITCH B	CUMULATIVE PITCH
	$\pm 0.5\text{mm}$ (.020")	$\pm 1.5\text{mm}$ (.059")	TOLERANCE
DO-41	5.0mm	26.0mm	2.0mm/20pitch
DO-41	5.0mm	52.4mm	2.0mm/10pitch
DO-15	5.0mm	52.4mm	2.0mm/10pitch
DO-201AD	10.0mm	52.4mm	2.0mm/10pitch
R-6	10.0mm	52.4mm	2.0mm/10pitch

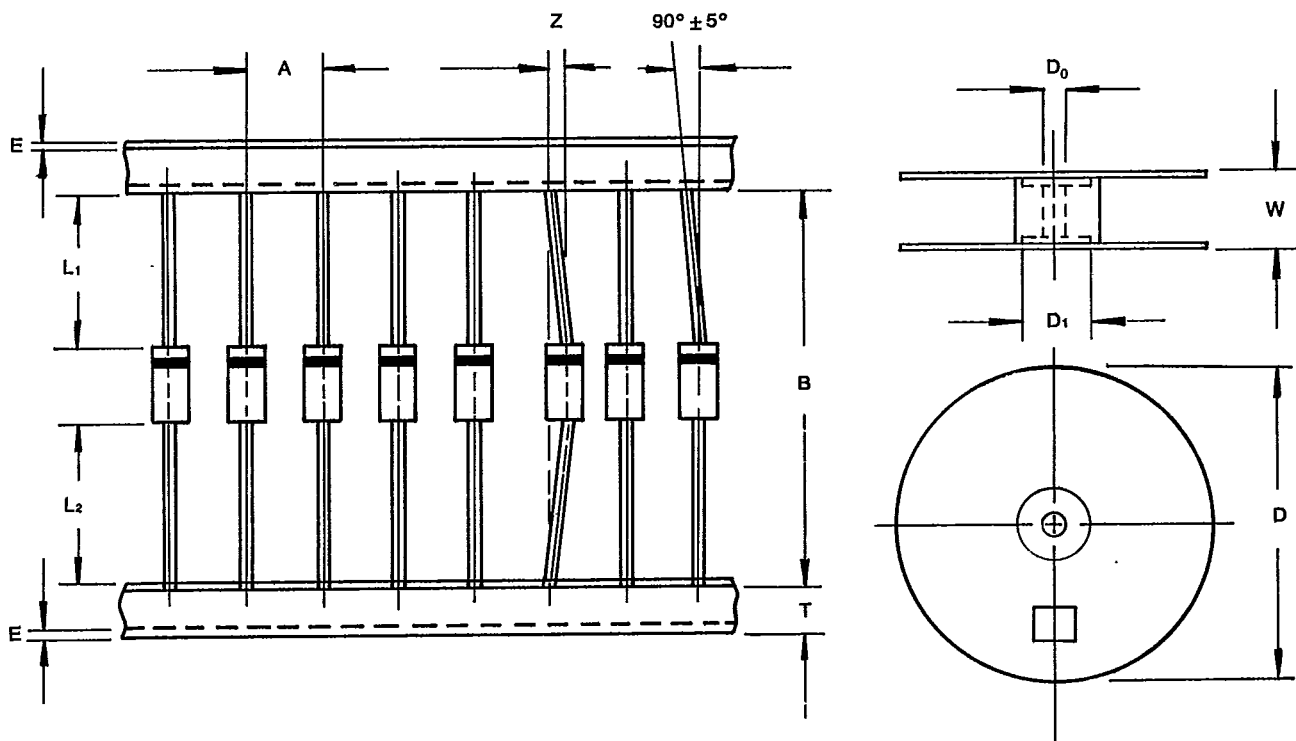

ITEM	SYMBOL	SPECIFICATIONS (mm)	SPECIFICATIONS (Inch)
Component alignment	Z	1.2 max.	0.048 max.
Tape width	T	6.0 ± 0.4	0.236 ± 0.016
Exposed adhesive	E	0.8 max.	0.032 max.
Body eccentricity	$ L1-L2 $	1.0 max.	0.040 max.
Reel outside diameter	D	330.0	13.0
Reel inner diameter	D1	85.7 ± 0.3	3.375 ± 0.012
Feed hole diameter	D0	16.6 ± 0.4	0.655 ± 0.016
Reel width	W	79.0 ± 1.0	3.110 ± 0.040

NOTE: 1. Each component lead shall be sandwiched between tapes for a minimum of 3.2mm (0.126")
2. The reel width 'W' for 26mm taping is $50.0 \pm 1.0\text{mm}$ ($1.97" \pm 0.040"$)

REEL TAPING SPECIFICATIONS FOR SURFACE MOUNT DEVICES

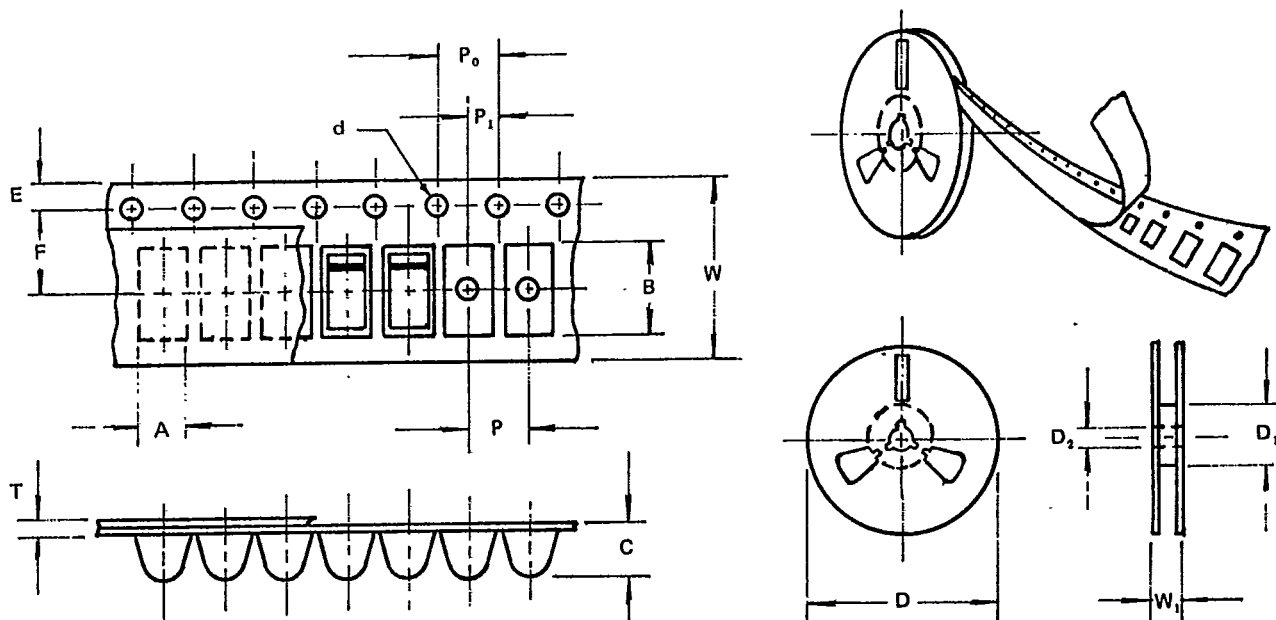

ITEM	SYMBOL	SPECIFICATIONS (mm)	SPECIFICATIONS (Inch)
Carrier width	A	3.2 max.	.126 max.
Carrier length	B	7.8 max.	.307 max.
Carrier depth	C	4.5 max.	.177 max.
Sprocket hole	d	1.5 ± 0.1	.059 ± .004
Reel outside diameter	D	178 ± 2.0	7.00 ± .079
Reel inner diameter	D1	50 min.	1.969 min.
Feed hole diameter	D2	13.0 ± 0.5	.512 ± .020
Sprocket hole position	E	1.75 ± 1.0	.069 ± .004
Punch hole position	F	5.5 ± 0.1	.217 ± .004
Punch hole pitch	P	4.0 ± 0.1	.157 ± .004
Sprocket hole pitch	P0	4.0 ± 0.1	.157 ± .004
Embossment center	P1	2.0 ± 0.05	.079 ± .002
Overall tape thickness	T	1.1 max.	.043 max.
Tape width	W	12.0 ± 0.3	.472 ± .012
Reel width	W1	18.4 max.	.724 max.

NOTE: 1. Devices are packed in accordance with EIA standard RS-481-A and specifications given above. Available only for SM-1 devices.
 2. Available on 7 inch (1500 ct.) diameter reels.

OUTLINE DRAWINGS

Unit: inch (mm)

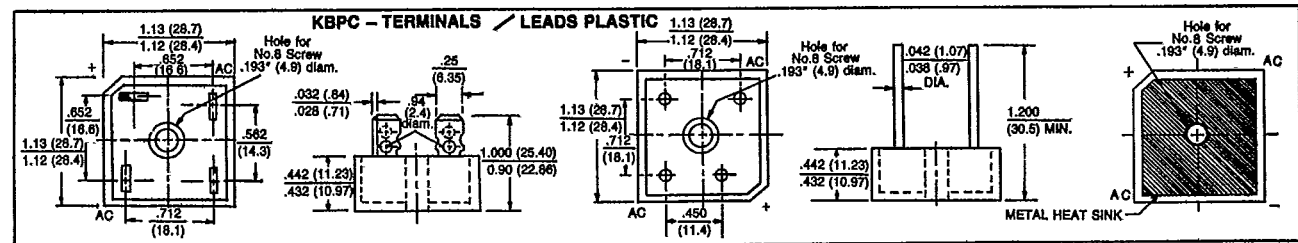
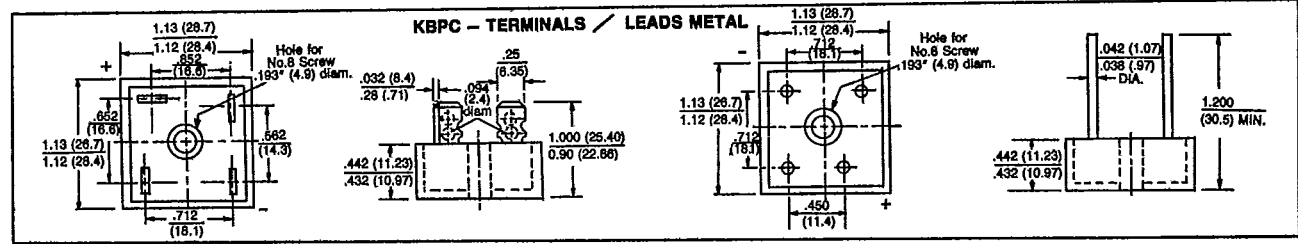
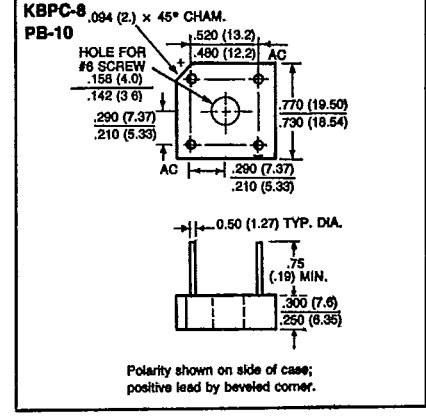
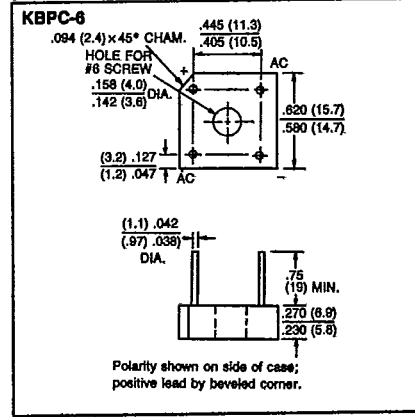
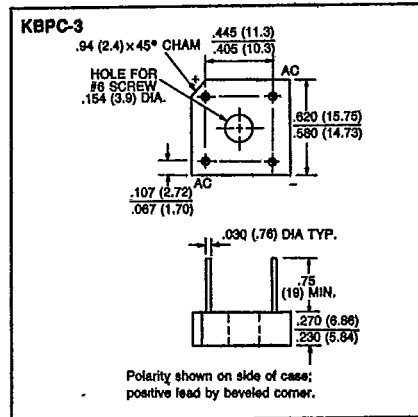
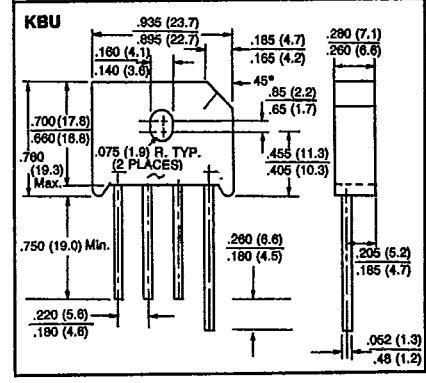
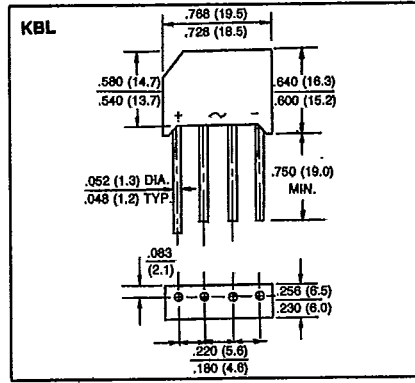
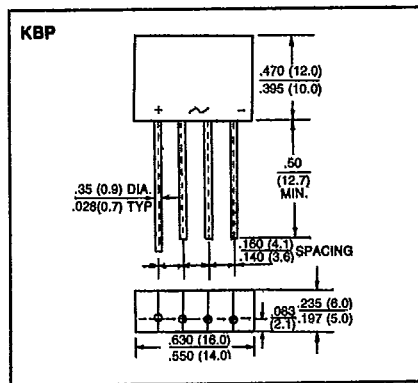
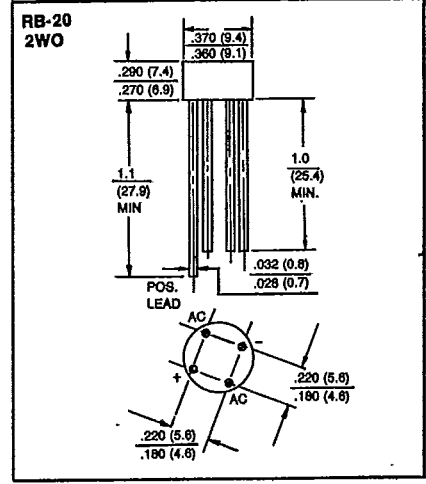
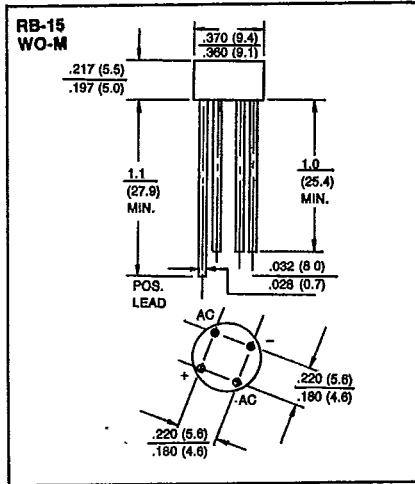
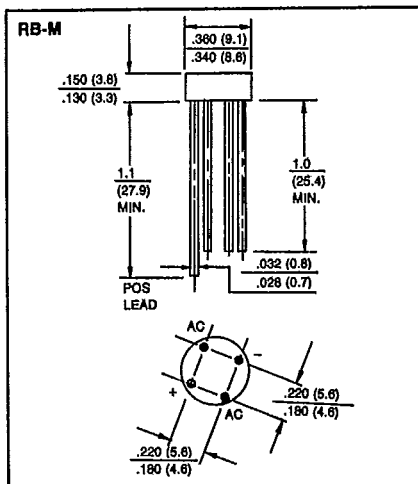

OUTLINE DRAWINGS

Unit: inch (mm)

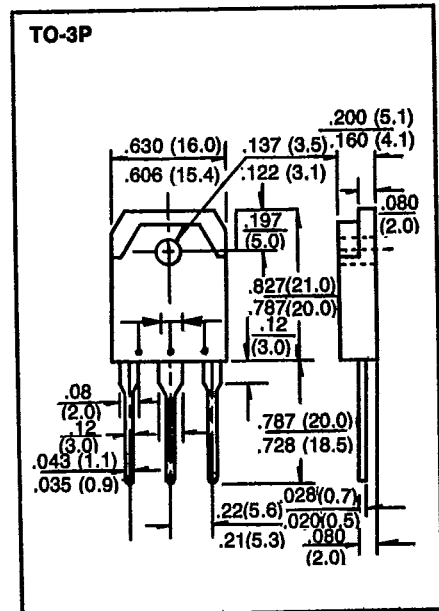
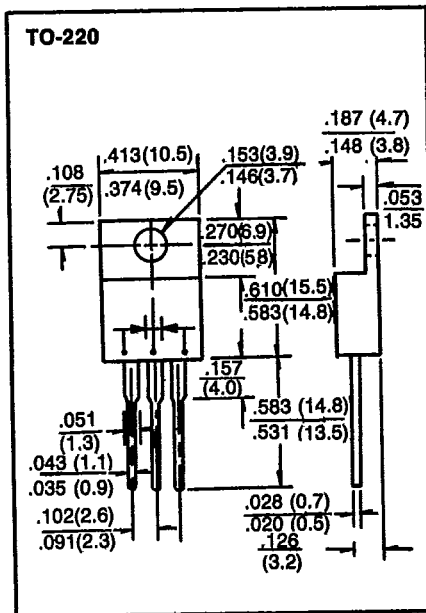
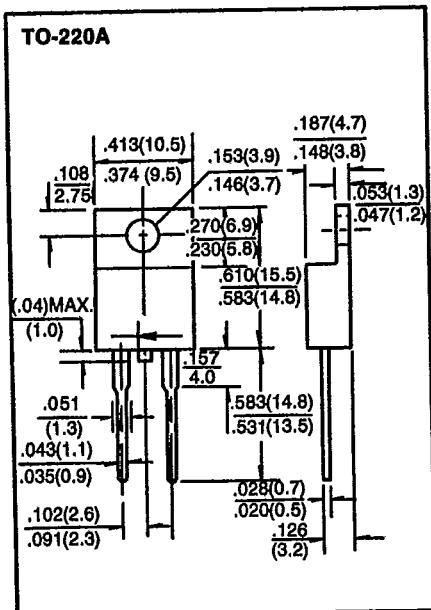
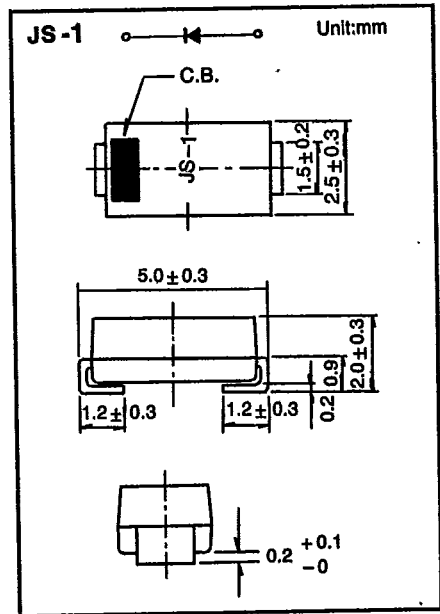
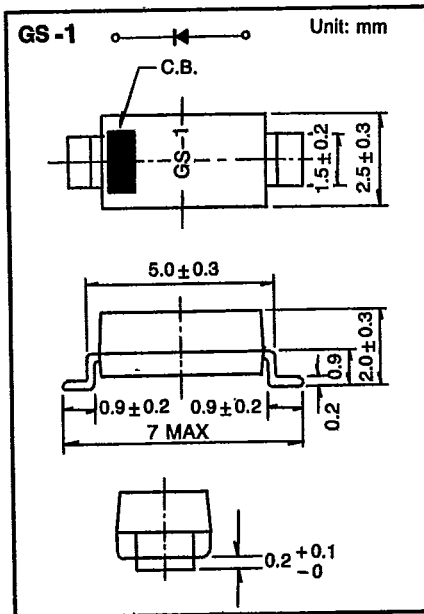
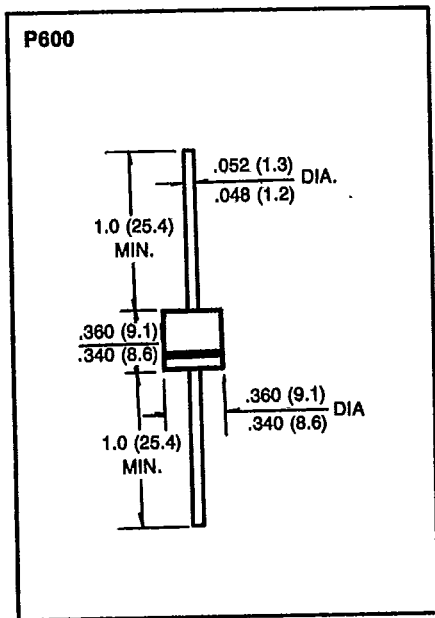
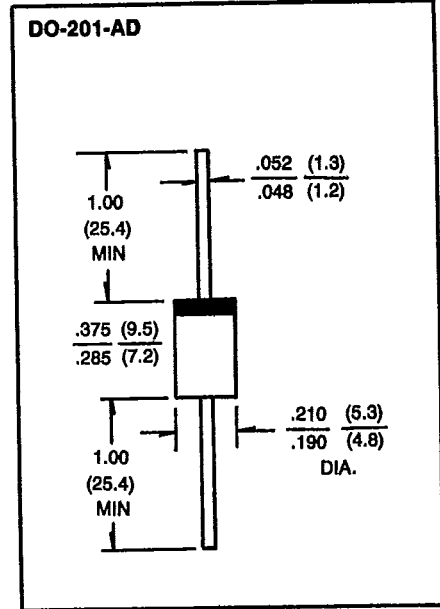
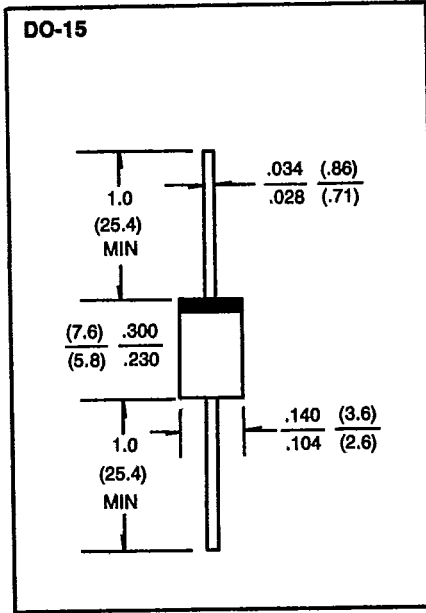
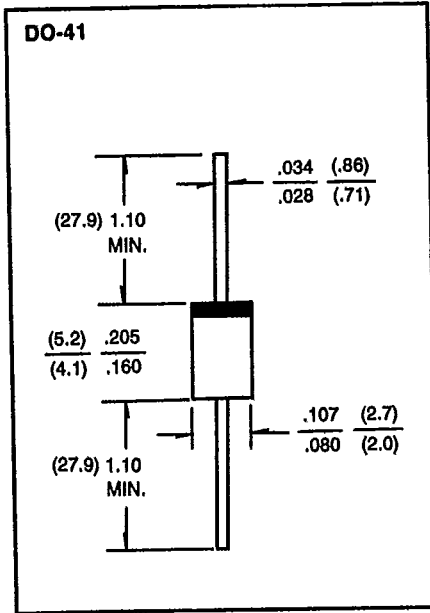

OUTLINE DRAWINGS

Unit: inch (mm)

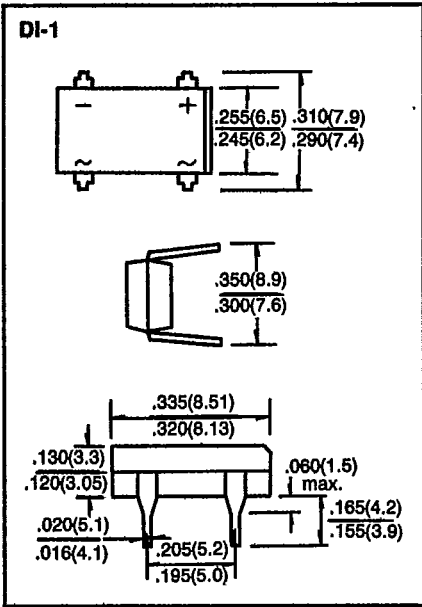

PACKAGING OF DIODE AND BRIDGE RECTIFIERS

BULK PACK

PACKAGE	INNER SIZE (m/m)	BOX (EA)	CARTON SIZE (m/m)	CARTON (EA)	APPROX. GROSS WEIGHT (Kg)
DO-41	200*84*21	1,000	465*225*270	50,000	19.1
DO-15	200*84*26	1,000	465*225*270	40,000	17.5
DO-201AD	200*84*42	500	465*225*270	12,500	17.3
DIP-1	490*145*85	2,500	510*365*310	20,000	14.4
RB-M/15/20	260*190*80	1,000	400*280*430	10,000	13.0/13.4/15.0
KBP	260*190*80	1,000	400*280*430	10,000	18.0
KBL40	260*190*80	500	400*280*430	5,000	25.5
KBPC-3/6	260*190*80	500	400*280*430	5,000	16.0/18.5
KBU	260*190*80	300	400*280*430	3,000	22.0
KBPC-8	260*190*80	300	400*280*430	3,000	19.0
KBPC-25/35 M	385*26*40	50	400*280*430	500	18.0
KBPC-25/35 P	385*26*40	50	400*280*430	500	12.0
TO-220*		400	390*275*365	8,000	18.1
TO-3P*		50	430*295*320	1,000	14.5

REEL PACK

PACKAGE	REEL (EA)	COMPONENT SPACE (m/m)	TAPE SPACE (m/m)	REEL DIA (m/m)	CARTON SIZE (m/m)	CARTON (EA)	APPROX. GROSS WEIGHT (Kg)
DO-41	5,000	5.0	51	330	355*355*425	25,000	12.4
DO-15	4,000	5.0	51	330	355*355*425	20,000	11.8
DO-201AD	1,250	9.5	51	330	355*355*425	6,250	11.6

AMMUNITION PACK

PACKAGE	REEL (EA)	COMPONENT SPACE (m/m)	TAPE SPACE (m/m)	REEL DIA (m/m)	CARTON SIZE (m/m)	CARTON (EA)	APPROX. GROSS WEIGHT (Kg)
DO-41	3,000	5.0	51	255*78*95	350*350*345	48,000	18.3
DO-15	1,500	5.0	51	255*78*95	350*350*345	22,500	12.5
DO-201AD	600	9.5	51	255*78*95	350*350*345	9,000	13.1
DO-41	3,000	5.0	26	255*51*95	330*310*268	42,000	15.1
DO-15	1,500	5.0	26	255*51*95	330*310*268	25,500	9.3