

REVISIONS

LTR	DESCRIPTION	DATE (YR-MO-DA)	APPROVED

REV																				
SHEET																				
REV																				
SHEET																				

REV STATUS OF SHEETS	REV																			
	SHEET	1	2	3	4	5	6	7	8	9	10	11								

PMIC N/A	PREPARED BY Marcia B Kelleher	DEFENSE ELECTRONICS SUPPLY CENTER DAYTON, OHIO 45444		
STANDARDIZED MILITARY DRAWING THIS DRAWING IS AVAILABLE FOR USE BY ALL DEPARTMENTS AND AGENCIES OF THE DEPARTMENT OF DEFENSE AMSC N/A	CHECKED BY Charles E Besore	MICROCIRCUIT, LINEAR, CMOS, FIXED/ADJUSTABLE, LOW POWER, STEP-UP SWITCHING REGULATOR, MONOLITHIC SILICON		
	APPROVED BY Michael A Frye			
	DRAWING APPROVAL DATE 92-11-19	SIZE A	CAGE CODE 67268	5962-92141
	REVISION LEVEL	SHEET 1	OF	11

1. SCOPE

1.1 Scope. This drawing forms a part of a one part - one part number documentation system (see 6.6 herein). Two product assurance classes consisting of military high reliability (device classes B, Q, and M) and space application (device classes S and V), and a choice of case outlines and lead finishes are available and are reflected in the Part or Identifying Number (PIN). Device class M microcircuits represent non-JAN class B microcircuits in accordance with 1.2.1 of MIL-STD-883, "Provisions for the use of MIL-STD-883 in conjunction with compliant non-JAN devices". When available, a choice of radiation hardness assurance (RHA) levels are reflected in the PIN.

1.2 PIN. The PIN shall be as shown in the following example:

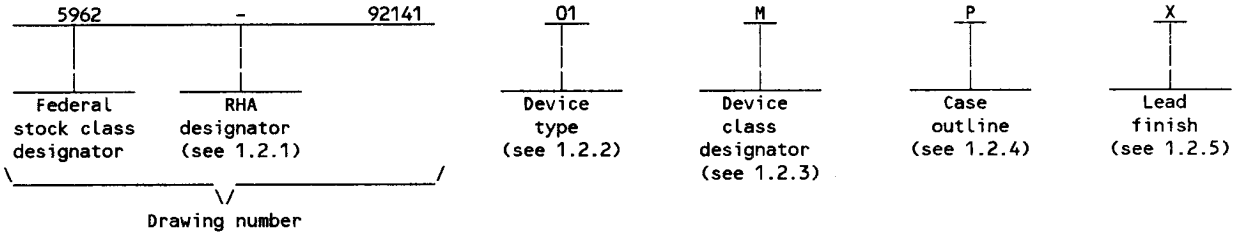

1.2.1 Radiation hardness assurance (RHA) designator. Device classes M, B, and S RHA marked devices shall meet the MIL-M-38510 specified RHA levels and shall be marked with the appropriate RHA designator. Device classes Q and V RHA marked devices shall meet the MIL-I-38535 specified RHA levels and shall be marked with the appropriate RHA designator. A dash (-) indicates a non-RHA device.

1.2.2 Device type(s). The device type(s) shall identify the circuit function as follows:

<u>Device type</u>	<u>Generic number</u>	<u>Circuit function</u>
01	MAX631A	Fixed +5 V/adjustable output low power step-up switching regulator
02	MAX631B	Fixed +5 V/adjustable output low power step-up switching regulator
03	MAX632A	Fixed +12 V/adjustable output low power step-up switching regulator
04	MAX632B	Fixed +12 V/adjustable output low power step-up switching regulator
05	MAX633A	Fixed +15 V/adjustable output low power step-up switching regulator
06	MAX633B	Fixed +15 V/adjustable output low power step-up switching regulator

1.2.3 Device class designator. The device class designator shall be a single letter identifying the product assurance level as follows:

<u>Device class</u>	<u>Device requirements documentation</u>
M	Vendor self-certification to the requirements for non-JAN class B microcircuits in accordance with 1.2.1 of MIL-STD-883
B or S	Certification and qualification to MIL-M-38510
Q or V	Certification and qualification to MIL-I-38535

1.2.4 Case outline(s). The case outline(s) shall be designated in MIL-STD-1835 and as follows:

<u>Outline letter</u>	<u>Descriptive designator</u>	<u>Terminals</u>	<u>Package style</u>
P	GDIP1-T8 or CDIP2-T8	8	Dual-in-line

1.2.5 Lead finish. The lead finish shall be as specified in MIL-M-38510 for classes M, B, and S or MIL-I-38535 for classes Q and V. Finish letter "X" shall not be marked on the microcircuit or its packaging. The "X" designation is for use in specifications when lead finishes A, B, and C are considered acceptable and interchangeable without preference.

STANDARDIZED MILITARY DRAWING DEFENSE ELECTRONICS SUPPLY CENTER DAYTON, OHIO 45444	SIZE A	5962-92141
		REVISION LEVEL SHEET 2

1.3 Absolute maximum ratings. 1/ 2/

Output voltage (V_{OUT}) 18.0 V dc
 Output voltage (L_X , LBO) 18.0 V dc
 Input voltage (LBI, V_{FB}) -0.3 V to ($+V_{OUT} + 0.3$ V)
 Output current (L_X) 450 mA peak
 Output current (LBO) 50 mA
 Power dissipation:
 Up to +70°C 640 mW
 Derate above +70°C 8 mW/°C
 Storage temperature range -65°C to +150°C
 Lead temperature (soldering, 10 seconds) +300°C
 Thermal resistance, junction-to-case (Θ_{JC}) See MIL-STD-1835
 Thermal resistance, junction-to-ambient (Θ_{JA}) 125°C/W
 Junction temperature (T_J) +150°C

1.4 Recommended operating conditions.

Input voltage range (V_{IN}) 2.4 V dc to 16.5 V dc
 Output voltage range (V_{OUT}) 2.4 V dc to 16.5 V dc
 Ambient operating temperature range (T_A) -55°C to +125°C

2. APPLICABLE DOCUMENTS

2.1 Government specifications, standards, bulletin, and handbook. Unless otherwise specified, the following specifications, standards, bulletin, and handbook of the issue listed in that issue of the Department of Defense Index of Specifications and Standards specified in the solicitation, form a part of this drawing to the extent specified herein.

SPECIFICATIONS

MILITARY

- MIL-M-38510 - Microcircuits, General Specification for.
- MIL-I-38535 - Integrated Circuits, Manufacturing, General Specification for.

STANDARDS

MILITARY

- MIL-STD-480 - Configuration Control-Engineering Changes, Deviations and Waivers.
- MIL-STD-883 - Test Methods and Procedures for Microelectronics.
- MIL-STD-1835 - Microcircuit Case Outlines.

BULLETIN

MILITARY

- MIL-BUL-103 - List of Standardized Military Drawings (SMD's).

HANDBOOK

MILITARY

- MIL-HDBK-780 - Standardized Military Drawings.

(Copies of the specifications, standards, bulletin, and handbook required by manufacturers in connection with specific acquisition functions should be obtained from the contracting activity or as directed by the contracting activity.)

1/ $T_A = +25^\circ\text{C}$, unless otherwise specified.

2/ Stresses above the absolute maximum rating may cause permanent damage to the device. Extended operation at the maximum levels may degrade performance and affect reliability.

STANDARDIZED MILITARY DRAWING DEFENSE ELECTRONICS SUPPLY CENTER DAYTON, OHIO 45444	SIZE A		5962-92141
		REVISION LEVEL	SHEET 3

2.2 Order of precedence. In the event of a conflict between the text of this drawing and the references cited herein, the text of this drawing shall take precedence.

3. REQUIREMENTS

3.1 Item requirements. The individual item requirements for device class M shall be in accordance with 1.2.1 of MIL-STD-883, "Provisions for the use of MIL-STD-883 in conjunction with compliant non-JAN devices" and as specified herein. The individual item requirements for device classes B and S shall be in accordance with MIL-M-38510 and as specified herein. For device classes B and S, a full electrical characterization table for each device type shall be included in this SMD. The individual item requirements for device classes Q and V shall be in accordance with MIL-I-38535, the device manufacturer's Quality Management (QM) plan, and as specified herein.

3.2 Design, construction, and physical dimensions. The design, construction, and physical dimensions shall be as specified in MIL-M-38510 for device classes M, B, and S and MIL-I-38535 for device classes Q and V and herein.

3.2.1 Case outline(s). The case outline(s) shall be in accordance with MIL-STD-1835.

3.2.2 Terminal connections. The terminal connections shall be as specified on figure 1.

3.2.3 Block diagram. The block diagram shall be as specified on figure 2.

3.3 Electrical performance characteristics and postirradiation parameter limits. Unless otherwise specified herein, the electrical performance characteristics and postirradiation parameter limits are as specified in table I and shall apply over the full ambient operating temperature range.

3.4 Electrical test requirements. The electrical test requirements shall be the subgroups specified in table II. The electrical tests for each subgroup are defined in table I.

3.5 Marking. The part shall be marked with the PIN listed in 1.2 herein. Marking for device class M shall be in accordance with MIL-STD-883 (see 3.1 herein). In addition, the manufacturer's PIN may also be marked as listed in MIL-BUL-103. Marking for device classes B and S shall be in accordance with MIL-M-38510. Marking for device classes Q and V shall be in accordance with MIL-I-38535.

3.5.1 Certification/compliance mark. The compliance mark for device class M shall be a "C" as required in MIL-STD-883 (see 3.1 herein). The certification mark for device classes B and S shall be a "J" or "JAN" as required in MIL-M-38510. The certification mark for device classes Q and V shall be a "QML" as required in MIL-I-38535.

3.6 Certificate of compliance. For device class M, a certificate of compliance shall be required from a manufacturer in order to be listed as an approved source of supply in MIL-BUL-103 (see 6.7.3 herein). For device classes Q and V, a certificate of compliance shall be required from a QML-38535 listed manufacturer in order to supply to the requirements of this drawing (see 6.7.2 herein). The certificate of compliance submitted to DESC-EC prior to listing as an approved source of supply for this drawing shall affirm that the manufacturer's product meets, for device class M the requirements of MIL-STD-883 (see 3.1 herein), or for device classes Q and V, the requirements of MIL-I-38535 and the requirements herein.

3.7 Certificate of conformance. A certificate of conformance as required for device class M in MIL-STD-883 (see 3.1 herein) or device classes B and S in MIL-M-38510 or for device classes Q and V in MIL-I-38535 shall be provided with each lot of microcircuits delivered to this drawing.

3.8 Notification of change for device class M. For device class M, notification to DESC-EC of change of product (see 6.2 herein) involving devices acquired to this drawing is required for any change as defined in MIL-STD-480.

3.9 Verification and review for device class M. For device class M, DESC, DESC's agent, and the acquiring activity retain the option to review the manufacturer's facility and applicable required documentation. Offshore documentation shall be made available onshore at the option of the reviewer.

3.10 Microcircuit group assignment for device classes M, B, and S. Device classes M, B, and S devices covered by this drawing shall be in microcircuit group number 76 (see MIL-M-38510, appendix E).

3.11 Serialization for device class S. All device class S devices shall be serialized in accordance with MIL-M-38510.

STANDARDIZED MILITARY DRAWING DEFENSE ELECTRONICS SUPPLY CENTER DAYTON, OHIO 45444	SIZE A		5962-92141
		REVISION LEVEL	SHEET 4

TABLE I. Electrical performance characteristics.

Test	Symbol	Conditions $V_{IN} = 3.0 \text{ V}$ $-55^\circ\text{C} \leq T_A \leq +125^\circ\text{C}$ unless otherwise specified	Group A subgroups	Device type	Limits 1/		Unit
					Min	Max	
Start-up voltage	V_{SU}	Voltage at V_{OUT}	1	ALL	1.5		V
			2,3		2.0		
Supply current 2/	I_S	L_X off	1,2,3	01,02		0.4	mA
				03,04		2.0	
				05,06		2.5	
Reference voltage	V_{REF}		1	ALL	1.24	1.38	V
			2,3		1.20	1.42	
Output voltage 2/	V_{OUT}	No load, $V_{FB} = \text{GND}$	1,2,3	01	4.75	5.25	V
				02	4.5	5.5	
				03	11.4	12.6	
				04	10.8	13.2	
				05	14.25	15.75	
				06	13.5	16.5	
Line regulation 3/	V_{RLINE}	$3 \text{ V} < V_{IN} < 6 \text{ V}$, $R_3 = 816 \text{ k}\Omega$, $R_4 = 100 \text{ k}\Omega$	1,2,3	ALL		0.2	% V_{OUT}
Load regulation 3/	V_{RLOAD}	$V_{IN} = 6 \text{ V}$, $I_{OUT} = 1 \text{ mA}$, 20 mA , $R_3 = 816 \text{ k}\Omega$, $R_4 = 100 \text{ k}\Omega$	1,2,3	ALL		1.0	% V_{OUT}
Oscillator duty cycle 2/	O_{DC}	$T_A = +25^\circ\text{C}$	1	ALL	40	60	%
On resistance, L_X	R_{ON}	$I_X = 100 \text{ mA}$, $V_{OUT} = 5.0 \text{ V}$, $T_A = +25^\circ\text{C}$	1	ALL		12	Ω
Low battery input bias current	I_{LBI}	$T_A = +25^\circ\text{C}$	1	ALL		10	nA
Leakage current, L_X	I_{LX}	$V_{LX} = 16.5 \text{ V}$	1	ALL		1.0	μA
			2,3			100	
Low battery input threshold voltage	V_{LBI}	$T_A = +25^\circ\text{C}$	1	ALL	1.18	1.44	V
Low battery output current	I_{LBO}	$V_{LBO} = +0.4 \text{ V}$, $V_{LBI} = +1.18 \text{ V}$	1,2,3	ALL	500		μA

See footnotes at end of table.

STANDARDIZED
MILITARY DRAWING
DEFENSE ELECTRONICS SUPPLY CENTER
DAYTON, OHIO 45444

SIZE
A

5962-92141

REVISION LEVEL

SHEET

5

TABLE I. Electrical performance characteristics - Continued.

Test	Symbol	Conditions $V_{IN} = 3.0 \text{ V}$ $-55^{\circ}\text{C} \leq T_A \leq +125^{\circ}\text{C}$ unless otherwise specified	Group A subgroups	Device type	Limits ^{1/}		Unit
					Min	Max	
Oscillator frequency ^{2/}	f_0	$T_A = +25^{\circ}\text{C}$	1	01	40	50	kHz
				02	35	60	
				03	45.5	56	
				04	40	65	
				05	45.5	56	
				06	40	65	
V_{FB} input bias current	I_{FB}	$T_A = +25^{\circ}\text{C}$	1	ALL		10	nA
Diode forward voltage	V_F	$T_A = +25^{\circ}\text{C}$, $I_F = 100 \text{ mA}$	1	ALL		1.0	V
On resistance, CP	R_{CPON}	$V_{OUT} = 5.0 \text{ V}$, $I_{OUT} = \pm 10 \text{ mA}$, $T_A = +25^{\circ}\text{C}$	1	ALL		140	Ω
Low battery output leakage current	I_{LBOL}	$V_{LBI} = +1.44 \text{ V}$, $V_{LBO} = +16.5 \text{ V}$,	1,2,3	ALL		3.0	μA

- ^{1/} The algebraic convention, whereby the most negative value is a minimum and the most positive a maximum, is used in this table. Negative current shall be defined as conventional current flow out of a device terminal.
- ^{2/} S1 set to B and S2 open provides a nominal output voltage of 5 volts for device types 01 and 02, 12 volts for device types 03 and 04 and 15 volts for device types 05 and 06. See figure 3.
- ^{3/} R3 and R4 give a nominal output voltage of 12 volts with S1 set to A and S2 closed. See figure 3.

STANDARDIZED
MILITARY DRAWING
DEFENSE ELECTRONICS SUPPLY CENTER
DAYTON, OHIO 45444

SIZE
A

5962-92141

REVISION LEVEL

SHEET

6

Device types	ALL
Case outline	P
Terminal number	Terminal symbol
1	LBI
2	LBO
3	GND
4	LX
5	V _{OUT}
6	CP
7	V _{FB}
8	COMP

FIGURE 1. Terminal connections.

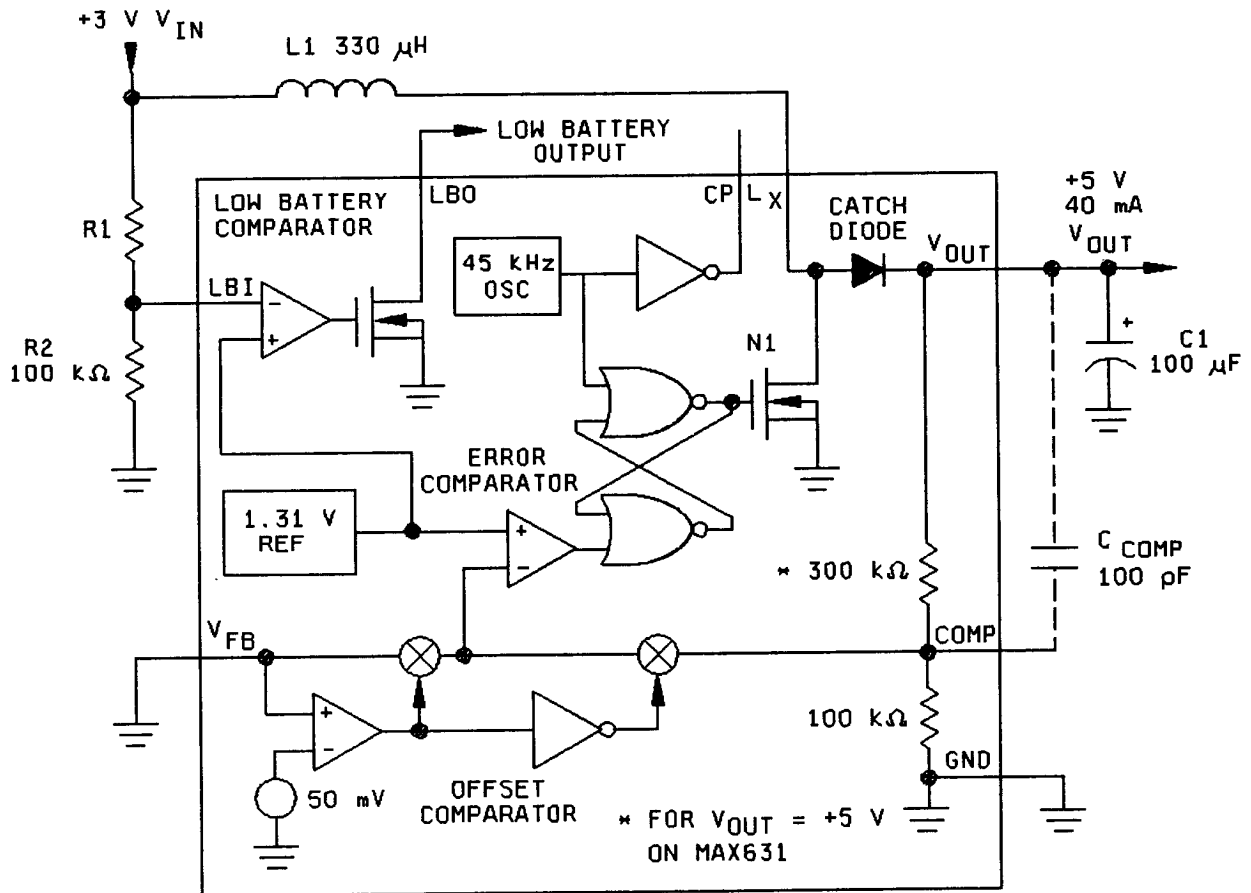

FIGURE 2. Block diagram.

STANDARDIZED MILITARY DRAWING DEFENSE ELECTRONICS SUPPLY CENTER DAYTON, OHIO 45444	SIZE A	5962-92141
	REVISION LEVEL	SHEET 7

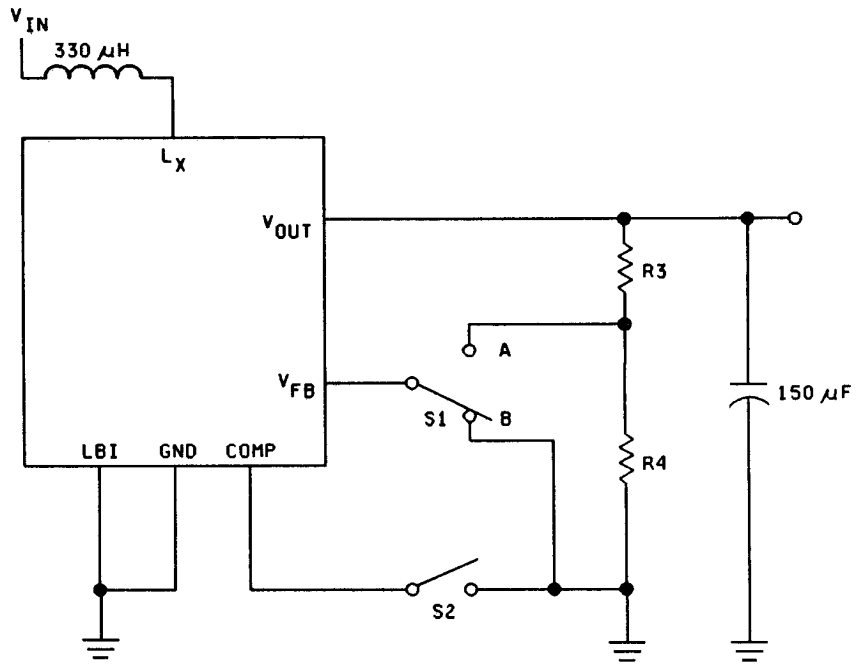

FIGURE 3. Test circuit.

STANDARDIZED MILITARY DRAWING DEFENSE ELECTRONICS SUPPLY CENTER DAYTON, OHIO 45444	SIZE A		5962-92141
		REVISION LEVEL	SHEET 8

TABLE II. Electrical test requirements.

Test requirements	Subgroups (in accordance with MIL-STD-883, method 5005, table I)			Subgroups (in accordance with MIL-I-38535, table III)	
	Device class M	Device class B	Device class S	Device class Q	Device class V
Interim electrical parameters (see 4.2)	1	1	1	1	1
Final electrical parameters (see 4.2)	1, ^{1/} 2, 3	1, ^{1/} 2, 3	1, ^{1/} 2, 3	1, ^{1/} 2, 3	1, ^{1/} 2, 3
Group A test requirements (see 4.4)	1, 2, 3	1, 2, 3	1, 2, 3	1, 2, 3	1, 2, 3
Group B end-point electrical parameters (see 4.4)			1, 2, 3		
Group C end-point electrical parameters (see 4.4)	1	1	1	1, 2, 3	1, 2, 3
Group D end-point electrical parameters (see 4.4)	1	1	1	1, 2, 3	1, 2, 3
Group E end-point electrical parameters (see 4.4)					

^{1/} PDA applies to subgroup 1.

4. QUALITY ASSURANCE PROVISIONS

4.1 Sampling and inspection. For device class M, sampling and inspection procedures shall be in accordance with section 4 of MIL-M-38510 to the extent specified in MIL-STD-883 (see 3.1 herein). For device classes B and S, sampling and inspection procedures shall be in accordance with MIL-M-38510 and method 5005 of MIL-STD-883, except as modified herein. For device classes Q and V, sampling and inspection procedures shall be in accordance with MIL-I-38535 and the device manufacturer's QM plan.

4.2 Screening. For device class M, screening shall be in accordance with method 5004 of MIL-STD-883, and shall be conducted on all devices prior to quality conformance inspection. For device classes B and S, screening shall be in accordance with method 5004 of MIL-STD-883, and shall be conducted on all devices prior to qualification and quality conformance inspection. For device classes Q and V, screening shall be in accordance with MIL-I-38535, and shall be conducted on all devices prior to qualification and technology conformance inspection.

4.2.1 Additional criteria for device classes M, B, and S.

a. Burn-in test, method 1015 of MIL-STD-883.

(1) Test condition A, B, C or D. For device class M, the test circuit shall be maintained by the manufacturer under document revision level control and shall be made available to the preparing or acquiring activity upon request. For device classes B and S, the test circuit shall be submitted to the qualifying activity. For device classes M, B, and S, the test circuit shall specify the inputs, outputs, biases, and power dissipation, as applicable, in accordance with the intent specified in test method 1015.

(2) $T_A = +125^\circ\text{C}$, minimum.

b. Interim and final electrical test parameters shall be as specified in table II herein.

STANDARDIZED MILITARY DRAWING DEFENSE ELECTRONICS SUPPLY CENTER DAYTON, OHIO 45444	SIZE A		5962-92141
		REVISION LEVEL	SHEET 9

4.2.2 Additional criteria for device classes Q and V.

- a. The burn-in test duration, test condition and test temperature, or approved alternatives shall be as specified in the device manufacturer's QM plan in accordance with MIL-I-38535. The burn-in test circuit shall be maintained under document revision level control of the device manufacturer's Technology Review Board (TRB) in accordance with MIL-I-38535 and shall be made available to the acquiring or preparing activity upon request. The test circuit shall specify the inputs, outputs, biases, and power dissipation, as applicable, in accordance with the intent specified in test method 1015.
- b. Interim and final electrical test parameters shall be as specified in table II herein.
- c. Additional screening for device class V beyond the requirements of device class Q shall be as specified in appendix B of MIL-I-38535.

4.3 Qualification inspection.

4.3.1 Qualification inspection for device classes B and S. Qualification inspection for device classes B and S shall be in accordance with MIL-M-38510. Inspections to be performed shall be those specified in method 5005 of MIL-STD-883 and herein for groups A, B, C, D, and E inspections (see 4.4.1 through 4.4.5).

4.3.2 Qualification inspection for device classes Q and V. Qualification inspection for device classes Q and V shall be in accordance with MIL-I-38535. Inspections to be performed shall be those specified in MIL-I-38535 and herein for groups A, B, C, D, and E inspections (see 4.4.1 through 4.4.5).

4.4 Conformance inspection. Quality conformance inspection for device class M shall be in accordance with MIL-STD-883 (see 3.1 herein) and as specified herein. Quality conformance inspection for device classes B and S shall be in accordance with MIL-M-38510 and as specified herein. Inspections to be performed for device classes M, B, and S shall be those specified in method 5005 of MIL-STD-883 and herein for groups A, B, C, D, and E inspections (see 4.4.1 through 4.4.5). Technology conformance inspection for classes Q and V shall be in accordance with MIL-I-38535 including groups A, B, C, D, and E inspections and as specified herein except where option 2 of MIL-I-38535 permits alternate in-line control testing.

4.4.1 Group A inspection. Tests shall be as specified in table II herein.

4.4.2 Group B inspection. The group B inspection end-point electrical parameters shall be as specified in table II herein. For device class S steady-state life tests, the test circuit shall be submitted to the qualifying activity.

4.4.3 Group C inspection. The group C inspection end-point electrical parameters shall be as specified in table II herein.

4.4.3.1 Additional criteria for device classes M and B. Steady-state life test conditions, method 1005 of MIL-STD-883:

- a. Test condition A, B, C, or D. For device class M, the test circuit shall be maintained by the manufacturer under document revision level control and shall be made available to the preparing or acquiring activity upon request. For device class B, the test circuit shall be submitted to the qualifying activity. For device classes M and B, the test circuit shall specify the inputs, outputs, biases, and power dissipation, as applicable, in accordance with the intent specified in test method 1005.
- b. $T_A = +125^{\circ}\text{C}$, minimum.
- c. Test duration: 1,000 hours, except as permitted by method 1005 of MIL-STD-883.

4.4.3.2 Additional criteria for device classes Q and V. The steady-state life test duration, test condition and test temperature, or approved alternatives shall be as specified in the device manufacturer's QM plan in accordance with MIL-I-38535. The test circuit shall be maintained under document revision level control by the device manufacturer's TRB in accordance with MIL-I-38535 and shall be made available to the acquiring or preparing activity upon request. The test circuit shall specify the inputs, outputs, biases, and power dissipation, as applicable, in accordance with the intent specified in test method 1005.

4.4.4 Group D inspection. The group D inspection end-point electrical parameters shall be as specified in table II herein.

5. PACKAGING

STANDARDIZED MILITARY DRAWING DEFENSE ELECTRONICS SUPPLY CENTER DAYTON, OHIO 45444	SIZE A		5962-92141
		REVISION LEVEL	SHEET 10

5.1 Packaging requirements. The requirements for packaging shall be in accordance with MIL-M-38510 for device classes M, B, and S and MIL-I-38535 for device classes Q and V.

6. NOTES

6.1 Intended use. Microcircuits conforming to this drawing are intended for use for Government microcircuit applications (original equipment), design applications, and logistics purposes.

6.1.1 Replaceability. Microcircuits covered by this drawing will replace the same generic device covered by a contractor-prepared specification or drawing.

6.1.2 Substitutability. Device classes B and Q devices will replace device class M devices.

6.2 Configuration control of SMD's. All proposed changes to existing SMD's will be coordinated with the users of record for the individual documents. This coordination will be accomplished in accordance with MIL-STD-481 using DD Form 1693, Engineering Change Proposal (Short Form).

6.3 Record of users. Military and industrial users shall inform Defense Electronics Supply Center when a system application requires configuration control and which SMD's are applicable to that system. DESC will maintain a record of users and this list will be used for coordination and distribution of changes to the drawings. Users of drawings covering microelectronic devices (FSC 5962) should contact DESC-EC, telephone (513) 296-6047.

6.4 Comments. Comments on this drawing should be directed to DESC-EC, Dayton, OH 45444, or telephone (513) 296-5377.

6.5 Abbreviations, symbols, and definitions. The abbreviations, symbols, and definitions used herein are defined in MIL-M-38510 and MIL-STD-1331.

6.6 One part - one part number system. The one part - one part number system described below has been developed to allow for transitions between identical generic devices covered by the four major microcircuit requirements documents (MIL-M-38510, MIL-H-38534, MIL-I-38535, and 1.2.1 of MIL-STD-883) without the necessity for the generation of unique PIN's. The four military requirements documents represent different class levels, and previously when a device manufacturer upgraded military product from one class level to another, the benefits of the upgraded product were unavailable to the Original Equipment Manufacturer (OEM), that was contractually locked into the original unique PIN. By establishing a one part number system covering all four documents, the OEM can acquire to the highest class level available for a given generic device to meet system needs without modifying the original contract parts selection criteria.

<u>Military documentation format</u>	<u>Example PIN under new system</u>	<u>Manufacturing source listing</u>	<u>Document listing</u>
New MIL-M-38510 Military Detail Specifications (in the SMD format)	5962-XXXXXZZ(B or S)YY	QPL-38510 (Part 1 or 2)	MIL-BUL-103
New MIL-H-38534 Standardized Military Drawings	5962-XXXXXZZ(H or K)YY	QML-38534	MIL-BUL-103
New MIL-I-38535 Standardized Military Drawings	5962-XXXXXZZ(Q or V)YY	QML-38535	MIL-BUL-103
New 1.2.1 of MIL-STD-883 Standardized Military Drawings	5962-XXXXXZZ(M)YY	MIL-BUL-103	MIL-BUL-103

6.7 Sources of supply.

6.7.1 Sources of supply for device classes B and S. Sources of supply for device classes B and S are listed in QPL-38510.

6.7.2 Sources of supply for device classes Q and V. Sources of supply for device classes Q and V are listed in QML-38535. The vendors listed in QML-38535 have submitted a certificate of compliance (see 3.6 herein) to DESC-EC and have agreed to this drawing.

6.7.3 Approved sources of supply for device class M. Approved sources of supply for class M are listed in MIL-BUL-103. The vendors listed in MIL-BUL-103 have agreed to this drawing and a certificate of compliance (see 3.6 herein) has been submitted to and accepted by DESC-EC.

STANDARDIZED MILITARY DRAWING DEFENSE ELECTRONICS SUPPLY CENTER DAYTON, OHIO 45444	SIZE A		5962-92141
		REVISION LEVEL	SHEET 11