

P33PCT240A/B-P33PCT241A/B-P33PCT244A/B T-52-07

OCTAL BUFFERS/LINE DRIVERS WITH 3-STATE OUTPUTS

ADVANCE INFORMATION

★ FEATURES

- 3.3V ± 0.2V Power Supply
- Center Power and Ground Pins
- Function, Speed and Drive Compatible with the Fastest Bipolar Logic
- "A" and "B" Versions for High Performance
- CMOS for Low Power Consumption
- 64 mA Sink Current (Com'I)
- 15 mA Source Current (Com'I)
- 3-State Outputs
- Inputs and Outputs Interface with TTL Logic Levels
- Outputs Meet Levels Required for CMOS Static RAM Low Power Standby Mode
- Input Clamp Diode to Limit Bus Reflections
- Low Ground Bounce

★ DESCRIPTION

The P33PCT240A/B, P33PCT241A/B and P33PCT244A/B are octal buffers and line drivers designed to be employed as memory address drivers, clock drivers and bus-oriented transmitters/receivers. The devices provide speed and drive capabilities equivalent to their fastest bipolar logic counterparts while reducing power dissipation. The input and output voltage levels allow direct interface with TTL devices without external components.

epitaxial substrates to use 0.4 micron effective channel lengths giving 250 picosecond loaded* internal gate delays. The nominal supply voltage is reduced from the conventional 5.0V to 3.3V, thus reducing output swings dramatically. This, together with the (lower inductance) center power and ground pins, and the extra power and extra ground pins, significantly reduces noise and ground bounce that would otherwise occur for very high speed circuitry.

The P33PCT240, P33PCT241 and P33PCT244 are manufactured with PACE III Technology™ which is Performance Advanced CMOS Engineered with two-level metal and

*For a fan-in/fan-out of 4 at 85°C junction temperature and 3.3V supply.



★ LOGIC DIAGRAMS

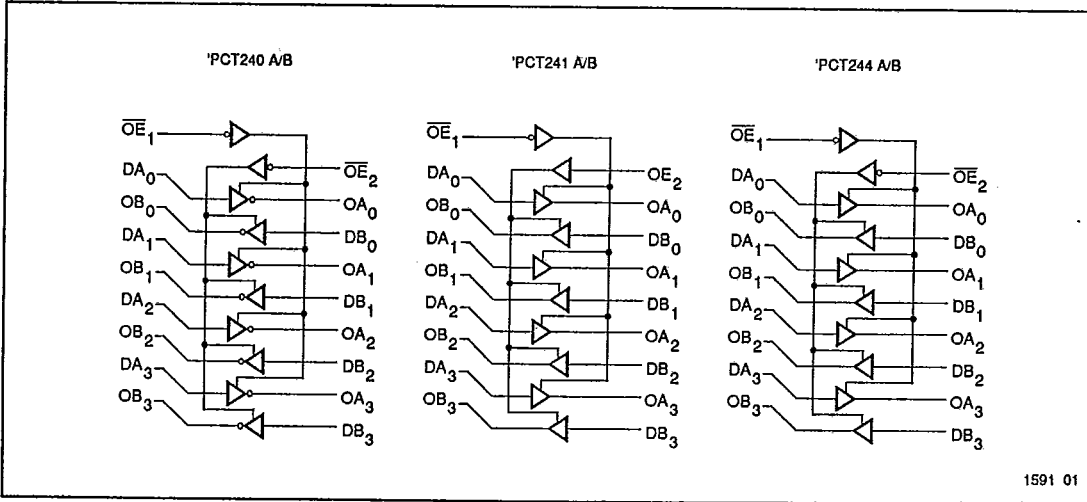

PIN CONFIGURATIONS

