

The documentation and process conversion measures necessary to comply with this revision shall be completed by 25 August 2001.

INCH-POUND

MIL-PRF-19500/393D
 25 May 2001
 SUPERSEDING
 MIL-PRF-19500/393C
 20 April 2000

PERFORMANCE SPECIFICATION

SEMICONDUCTOR DEVICE, TRANSISTOR, NPN, SILICON POWER
 TYPES 2N3418, 2N3418S, 2N3419, 2N3419S, 2N3420, 2N3420S, 2N3421, 2N3421S
 JAN, JANTX, JANTXV, JANS, JANHC, and JANKC

This specification is approved for use by all Departments and Agencies of the Department of Defense.

1. SCOPE

1.1. Scope. This specification covers the performance requirements for NPN, silicon, transistors for use in medium power switching applications. Four levels of product assurance are provided for each device type, and two levels of product assurance for die (element evaluation) are provided, as specified in MIL-PRF-19500.

1.2. Physical dimensions. See figure 1 (similar to TO-5 for long leaded devices and TO-39 for short leaded devices), figure 2, and figure 3 for JANHC and JANKC (die) dimensions.

1.3. Maximum ratings.

Type	P_T $T_A = +25^\circ\text{C}$ (1)	P_T $T_C = +100^\circ\text{C}$ (2)	V_{CBO}	V_{CEO}	V_{EBO}	I_C	I_C (3)	T_{STG} and T_{OP}
	<u>W</u>	<u>W</u>	<u>V dc</u>	<u>V dc</u>	<u>V dc</u>	<u>A dc</u>	<u>A dc</u>	<u>°C</u>
2N3418, 2N3418S	1.0	15	85	60	8	3	5	-65 to +200
2N3419, 2N3419S	1.0	15	125	80	8	3	5	-65 to +200
2N3420, 2N3420S	1.0	15	85	60	8	3	5	-65 to +200
2N3421, 2N3421S	1.0	15	125	80	8	3	5	-65 to +200

- (1) Derate linearly at 5.72 mW/°C above $T_A > +25^\circ\text{C}$.
- (2) Derate linearly at 150 mW/°C above $T_C > +100^\circ\text{C}$.
- (3) This value applies for $t_p \leq 1$ ms, duty cycle ≤ 50 percent.

Beneficial comments (recommendations, additions, deletions) and any pertinent data which may be of use in improving this document should be addressed to: Defense Supply Center Columbus, ATTN: DSCC-VAC, Post Office Box 3990, Columbus, OH 43216-5000, by using the Standardization Document Improvement Proposal (DD Form 1426) appearing at the end of this document or by letter.

1.4. Primary electrical characteristics at T_A = +25°C.

Limits	h _{FE2} (1)		h _{FE4} (1)		V _{CE(sat)} ₁ (1)	V _{BE(sat)} 1	h _{fe}	C _{obo}	R _{θJC}
	V _{CE} = 2 V dc I _C = 1 A dc		V _{CE} = 5 V dc I _C = 5 A dc		I _C = 1 A dc I _B = 0.1 A dc	I _C = 1 A dc I _B = 0.1 A dc	V _{CE} = 10 V dc I _C = 0.1 A dc f = 20 MHz	V _{CB} = 10 V dc I _E = 0 100 kHz ≤ f ≤ 1 MHz	
	2N3418 2N3418S 2N3419 2N3419S	2N3420 2N3420S 2N3421 2N3421S	2N3418 2N3418S 2N3419 2N3419S	2N3420 2N3420S 2N3421 2N3421S					
Min	20	40	10	15	<u>V dc</u>	<u>V dc</u>	1.3	<u>pF</u>	<u>°C/W</u>
Max	60	120			0.25	1.2	8	150	6.67

(1) Pulsed (see 4.5.1).

2. APPLICABLE DOCUMENTS

2.1 General. The documents listed in this section are specified in sections 3 and 4 of this specification. This section does not include documents cited in other sections of this specification or recommended for additional information or as examples. While every effort has been made to ensure the completeness of this list, document users are cautioned that they must meet all specified requirements documents cited in sections 3 and 4 of this specification, whether or not they are listed.

2.2 Government documents.

2.2.1 Specifications, standards, and handbooks. The following specifications, standards, and handbooks form a part of this document to the extent specified herein. Unless otherwise specified, the issues of these documents are those listed in the issue of the Department of Defense Index of Specifications and Standards (DoDISS) and supplement thereto, cited in the solicitation (see 6.2).

SPECIFICATION

DEPARTMENT OF DEFENSE

MIL-PRF-19500 - Semiconductor Devices, General Specification for.

STANDARD

DEPARTMENT OF DEFENSE

MIL-STD-750 - Test Methods for Semiconductor Devices.

(Unless otherwise indicated, copies of the above specifications, standards, and handbooks are available from the Document Automation and Production Services (DAPS), Building 4D (DPM-DODSSP), 700 Robbins Avenue, Philadelphia, PA 19111-5094.)

2.3 Order of precedence. In the event of a conflict between the text of this document and the references cited herein, the text of this document takes precedence. Nothing in this document, however, supersedes applicable laws and regulations unless a specific exemption has been obtained.

Symbol	Dimensions				Note
	Inches		Millimeters		
	Min	Max	Min	Max	
CD	.305	.335	7.75	8.51	
CH	.240	.260	6.10	6.60	
HD	.335	.370	8.51	9.40	
LC	.200 TP		5.08 TP		6
LD	.016	.021	0.41	0.53	
LL	.500	.750	12.7	19.05	7
LU	See notes 7, 13, 14				
L1		.050		1.27	7
L2	.250		6.35		7
P	.100		2.54		5
Q		.040		0.86	4
TL	.029	.045	0.74	1.14	3,10
TW	.028	.034	0.71	.86	9,10
r		.010		0.25	11
α	45° TP		45° TP		6

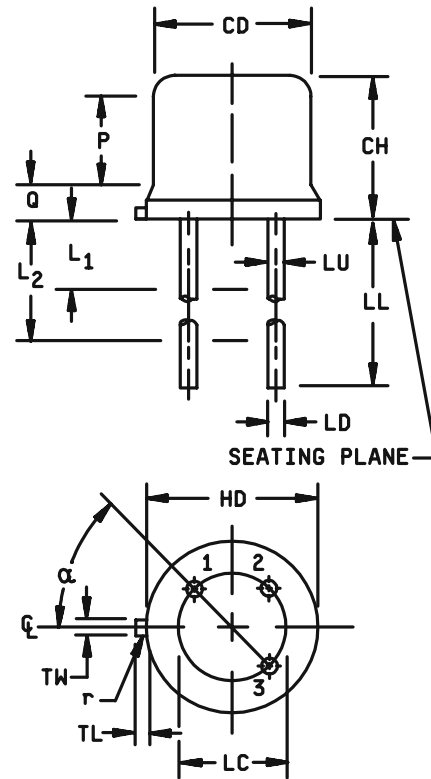

NOTES:

1. Dimensions are in inches.
2. Metric equivalents are given for general information only.
3. Symbol TL is measured from HD maximum.
4. Details of outline in this zone are optional.
5. Symbol CD shall not vary more than .010 inch (0.25 mm) in zone P. This zone is controlled for automatic handling.
6. Leads at gauge plane .054 inch (1.37 mm) +.001 inch (0.03 mm) -.000 inch (0.00 mm) below seating plane shall be within .007 inch (0.18 mm) radius of TP relative to tab. Device may be measured by direct methods or by gauge.
7. Symbol LU applies between L₁ and L₂. Dimension LD applies between L₂ and LL minimum. Diameter is uncontrolled in L₁ and beyond LL minimum.
8. Lead number three is electrically connected to case.
9. Beyond r maximum, TW shall be held for a minimum length of .021 inch (0.53 mm).
10. Lead number 4 omitted on this variation.
11. Symbol r applied to both inside corners of tab.
12. For transistor types 2N3418S, 2N3419S, 2N3420S, 2N3421S, LL is .500 (12.70 mm) minimum and .750 (19.05 mm) maximum.
13. For transistor types 2N3418, 2N3419, 2N3420, 2N3421, LL is .500 (38.10 mm) minimum, and 1.750 (44.45 mm) maximum.
14. In accordance with ANSI Y14.5M, diameters are equivalent to ϕ x symbology.
15. Lead 1 is emitter, lead 2 is base, and lead 3 is collector.

FIGURE 1. Physical dimensions.

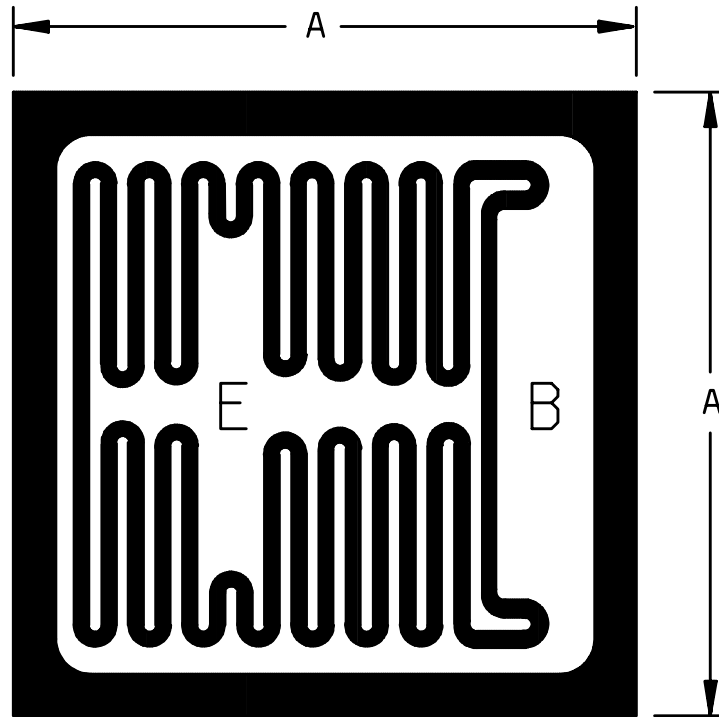

Letter	Dimensions			
	Inches		Millimeters	
	Min	Max	Min	Max
A	.117	.127	2.97	3.23

NOTES:

1. Dimensions are in inches.
 2. Metric equivalents are given for general information only.
 3. Unless otherwise specified, tolerance is .005 (0.13 mm).
 4. The physical characteristics of the die are;
 - Thickness: .008 (0.20 mm) to .012 (0.30 mm), tolerance is .005 (0.13 mm).
 - Top metal: Aluminum, 40,000 Å minimum, 50,000 Å nominal.
 - Back metal: Gold 2,500 Å minimum, 3,000 Å nominal.
 - Back side: Collector.
- Bonding pad: B = .015 (0.38 mm) x .0072 (.183).
 E = .015 (0.38 mm) x .0060 (.152).

FIGURE 2. JANHCA and JANKCA die dimensions.

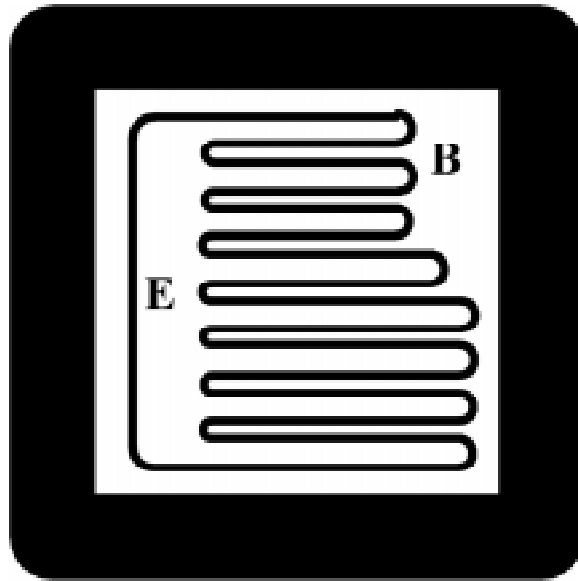

1. Chip size: .075 x .075 inch \pm .002 inches (1.905 x 1.905 mm \pm 0.051 mm).
2. Chip thickness: .010 \pm .0015 inches nominal (0.254 \pm 0.0381 mm).
3. Top metal: Aluminum 30,000 Å minimum, 33,000 Å nominal.
4. Back metal:
A. Al/Ti/Ni/Ag 12kÅ/3kÅ/7kÅ/7kÅ min., 15kÅ/5kÅ/10kÅ/10kÅ nom.
B. Gold 2,500Å minimum, 3000Å nominal.
5. Backside: Collector.
6. Bonding pad: B = .023 x .008 inch (0.5842 x 0.2032 mm), E = .049 x .008 inch (1.2446 x 0.2032 mm).

FIGURE 3. JANHC and JANKC B-version die dimensions.

3. REQUIREMENTS

3.1 General. The requirements for acquiring the product described herein shall consist of this document and MIL-PRF-19500.

3.2 Qualification. Devices furnished under this specification shall be products that are manufactured by a manufacturer authorized by the qualifying activity for listing on the applicable qualified manufacturer's list (QML) before contract award (see 4.2 and 6.4).

3.3 Abbreviations, symbols, and definitions. Abbreviations, symbols, and definitions used herein shall be as specified in MIL-PRF-19500.

3.4 Interface and physical dimensions. Interface and physical dimensions shall be as specified in MIL-PRF-19500, and on figure 1, (similar to TO-5 and TO-39) and figures 2 and figure 3 (die) herein.

3.4.1 Lead finish. Lead finish shall be solderable in accordance with MIL-PRF-19500, MIL-STD-750, and herein. Where a choice of lead finish is desired, it shall be specified in the acquisition document (see 6.2).

3.5 Marking. Marking shall be in accordance with MIL-PRF-19500.

3.6 Electrical performance characteristics. Unless otherwise specified herein, the electrical performance characteristics are as specified in paragraph 1.3, 1.4, and table I.

3.7 Electrical test requirements. The electrical test requirements shall be the subgroups specified in table I herein.

3.8 Workmanship. Semiconductor devices shall be processed in such a manner as to be uniform in quality and shall be free from other defects that will affect life, serviceability, or appearance.

4. VERIFICATION

4.1 Classification of inspections. The inspection requirements specified herein are classified as follows:

- a. Qualification inspection (see 4.2).
- b. Screening (see 4.3).
- c. Conformance inspection (see 4.4).

4.2 Qualification inspection. Qualification inspection shall be in accordance with MIL-PRF-19500 and as specified herein.

4.2.1 JANHC and JANKC qualification. JANHC and JANKC qualification inspection shall be in accordance with MIL-PRF-19500.

MIL-PRF-19500/393D

4.3 Screening (JANS, JANTX, and JANTXV levels only). Screening shall be in accordance with table IV of MIL-PRF-19500, and as specified herein. The following measurements shall be made in accordance with table I herein. Devices that exceed the limits of table I herein shall not be acceptable.

Screen (see table IV of MIL-PRF-19500)	Measurement	
	JANS level	JANTX and JANTXV levels
3c	Thermal impedance (see 4.3.3)	Thermal impedance (see 4.3.3)
9	I_{CEX1} and h_{FE2}	I_{CEX1}
11	I_{CEX1} ; h_{FE2} ; ΔI_{CEX1} = 100 percent or 50 nA dc, whichever is greater; Δh_{FE2} = +15, -10 percent change of initial value.	I_{CEX1} and h_{FE2} ; ΔI_{CEX1} = 100 percent or 100 nA dc, whichever is greater.
12	See 4.3.1	See 4.3.1
13	Subgroups 2 and 3 of table I herein; ΔI_{CEX1} = 100 percent or 50 nA dc, whichever is greater; Δh_{FE2} = +15, -10 percent of initial value.	Subgroup 2 of table I herein; ΔI_{CEX1} = 100 percent or 100 nA dc, whichever is greater; Δh_{FE2} = +20, -10 percent of initial value.

4.3.1. Power burn-in conditions. Power burn-in conditions are as follows: V_{CB} = 10 - 30 V dc. Power shall be applied to achieve T_J = +175°C minimum and a minimum P_D = 75 percent of P_T maximum rated as defined in 1.3.

4.3.2 Screening JANHC or JANKC. Screening of die shall be in accordance with MIL-PRF-19500.

4.3.3. Thermal impedance ($Z_{\theta JX}$ measurements). The $Z_{\theta JX}$ measurements shall be performed in accordance with method 3131 of MIL-STD-750.

- a. I_M measurement current ----- 10 mA.
- b. I_H forward heating current ----- 2 A (min).
- c. t_H heating time ----- 10 ms.
- d. t_{md} measurement delay time ----- 50 μ s max.
- e. V_{CE} collector-emitter voltage ----- 10 V dc minimum.

The maximum limit for $Z_{\theta JX}$ under these test conditions are $Z_{\theta JX}$ (max) = 55°C/W.

4.4 Conformance inspection. Conformance inspection shall be in accordance with MIL-PRF-19500 and as specified herein.

4.4.1 Group A inspection. Group A inspection shall be conducted in accordance with MIL-PRF-19500, and table I herein. Electrical measurements (end-points) shall be in accordance with the applicable inspections of table I, group A, subgroup 2 herein.

MIL-PRF-19500/393D

4.4.2 Group B inspection. Group B inspection shall be conducted in accordance with the conditions specified for subgroup testing in table VIa (JANS) of MIL-PRF-19500 and 4.4.2.1. Electrical measurements (end-points) and shall be in accordance with group A, subgroup 2. Delta requirements shall be in accordance with table III and the notes for table III herein. See 4.4.2.2 for JAN, JANTX, and JANTXV group B testing. Electrical measurements (end-points) for JAN, JANTX, and JANTXV shall be after each step in 4.4.2.2 and shall be in accordance with group A, subgroup 2 herein. Delta requirements shall be in accordance with table III and the notes for table III herein.

4.4.2.1 Group B inspection, table VIa (JANS) of MIL-PRF-19500.

<u>Subgroup</u>	<u>Method</u>	<u>Condition</u>
B3	2037	Test condition A. All internal wires for each device shall be pulled separately.
B4	1037	$V_{CE} = 5 \text{ V dc}$, 2,000 cycles.
B5	1027	$V_{CE} = 5 \text{ V dc}$, P_T adjusted to achieve T_J and time required in MIL-PRF-19500.
B7	3053	$T_A = +25^\circ\text{C}$, $I_B = 0.5 \text{ A dc}$, $I_C = 3.0 \text{ A dc}$, see figure 4.

4.4.2.2 Group B inspection, (JAN, JANTX, and JANTXV). Separate samples may be used for each step. In the event of a group B failure, the manufacturer may pull a new sample at double size from either the failed assembly lot or from another assembly lot from the same wafer lot. If the new "assembly lot" option is exercised, the failed assembly lot shall be scrapped.

<u>Step</u>	<u>Method</u>	<u>Condition</u>
1	1039	Steady-state life: Test condition B, 340 hours, $V_{CB} = 10 - 30 \text{ V dc}$, power shall be applied to achieve $T_J = +175^\circ\text{C}$ minimum and a minimum of $P_D = 75$ percent of maximum rated P_T as defined in 1.3. $n = 45$ devices, $c = 0$.
2	1039	The steady-state life test of step 1 shall be extended to 1,000 hours for each die design. Samples shall be selected from a wafer lot every twelve months of wafer production. Group B, step 2 shall not be required more than once for any single wafer lot. $n = 45$, $c = 0$.
3	1032	High-temperature life (non-operating), $t = 340$ hours, $T_A = +200^\circ\text{C}$. $n = 22$, $c = 0$.
4	3053	$T_A = +25^\circ\text{C}$, $I_B = 0.5 \text{ A dc}$, $I_C = 3.0 \text{ A dc}$, see figure 4.

4.4.2.3 Group B sample selection. Samples selected from group B inspection shall meet all of the following requirements:

- a. For JAN, JANJ, JANTX, and JANTXV samples shall be selected randomly from a minimum of three wafers (or from each wafer in the lot) from each wafer lot. For JANS, samples shall be selected from each inspection lot. See MIL-PRF-19500.
- b. Must be chosen from an inspection lot that has been submitted to and passed group A, subgroup 2, conformance inspection. When the final lead finish is solder or any plating prone to oxidation at high temperature, the samples for life test (subgroups B4 and B5 for JANS, and group B for JAN, JANTX, and JANTXV) may be pulled prior to the application of final lead finish.

4.4.3. Group C inspection. Group C inspection shall be conducted in accordance with the conditions specified for subgroup testing in table VII of MIL-PRF-19500 and herein. Electrical measurements (end-points) shall be in accordance with group A, subgroup 2 herein. Delta measurements shall be in accordance with table III and the notes for table III herein.

4.4.3.1 Group C inspection, table VII of MIL-PRF-19500.

<u>Subgroup</u>	<u>Method</u>	<u>Condition</u>
C2	2036	Test condition E.
C6	1026	$T_A = +25 \pm 5^\circ\text{C}$; $T_J = +150^\circ\text{C}$ minimum. (Not applicable to JAN, JANTX, and JANTXV). $V_{CB} = 40 \text{ V dc}$ for types 2N3418, 2N3418S, 2N3420, and 2N3420S. $V_{CB} = 60 \text{ V dc}$ for types 2N3419, 2N3419S, 2N3421, and 2N3421S.

4.4.3.2 Group C sample selection. Samples for subgroups in group C shall be chosen at random from any inspection lot containing the intended package type and lead finish procured to the same specification which is submitted to and passes group A tests for conformance inspection. When the final lead finish is solder or any plating prone to oxidation at high temperature, the samples for C6 life test may be pulled prior to the application of final lead finish. Testing of a subgroup using a single device type enclosed in the intended package type shall be considered as complying with the requirements for that subgroup.

4.4.4 Group E inspection. Group E inspection shall be performed for qualification or re-qualification only. In case qualification was awarded to a prior revision of the associated specification that did not request the performance of table II tests, the tests specified in table II herein must be performed to maintain qualification.

4.5 Methods of inspection. Methods of inspection shall be as specified in the appropriate tables and as follows.

4.5.1 Pulse measurements. Conditions for pulse measurement shall be as specified in section 4 of MIL-STD-750.

4.5.2 Thermal resistance. Thermal resistance measurements shall be conducted in accordance with test method 3131 of MIL-STD-750. The following details shall apply:

- a. Collector current magnitude during power applications shall be 1.0 A dc.
- b. Collector to emitter voltage magnitude shall be 10 V dc.
- c. The measuring current magnitude shall be 1 mA dc.
- d. Reference temperature measuring point shall be the case.
- e. Reference point temperature shall be $+25^\circ\text{C} \leq T_R \leq +75^\circ\text{C}$ and recorded before the test is started.
- f. Mounting arrangement shall be out to heat sink.
- g. Maximum limits for $R_{\theta JC}$ shall be 6.67°C/W .

MIL-PRF-19500/393D

TABLE I. Group A inspection.

Inspection <u>1/</u>	MIL-STD-750		Symbol	Limit		Unit
	Method	Conditions		Min	Max	
<u>Subgroup 1 2/</u>						
Visual and mechanical <u>3/</u> examination	2071	n = 45 devices, c = 0				
Solderability <u>3/ 4/</u>	2026	n = 15 leads, c = 0				
Resistance to solvents <u>3/ 4/ 5/</u>	1022	n = 15 devices, c = 0				
Temp cycling <u>3/ 4/</u>	1051	Test condition C, 25 cycles. n = 22 devices, c = 0				
Hermetic seal <u>4/</u> Fine leak Gross leak	1071	n = 22 devices, c = 0				
Electrical measurements <u>4/</u>		Group A, subgroup 2				
Bond strength <u>3/ 4/</u>	2037	Precondition T _A = +250°C at t = 24 hrs or T _A = +300°C at t = 2 hrs n = 11 wires, c = 0				
<u>Subgroup 2</u>						
Breakdown voltage collector to emitter	3011	Bias condition D; I _C = 50 mA dc, I _B = 0, pulsed (see 4.5.1)	V _{(BR)CEO}			
2N3418, 2N3418S 2N3420, 2N3420S				60		V dc
2N3419, 2N3419S 2N3421, 2N3421S				80		V dc
Collector to emitter cutoff current	3041	Bias condition A; V _{BE} = -0.5 V dc	I _{CEX1}			
2N3418, 2N3418S 2N3420, 2N3420S		V _{CE} = 80 V dc			0.3	μA dc
2N3419, 2N3419S 2N3421, 2N3421S		V _{CE} = 120 V dc			0.3	μA dc
Collector to emitter cutoff current	3041	Bias condition D; I _B = 0	I _{CEO}			
2N3418, 2N3418S 2N3420, 2N3420S		V _{CE} = 45 V dc			5.0	μA dc
2N3419, 2N3419S 2N3421, 2N3421S		V _{CE} = 60 V dc			5.0	μA dc

See footnotes at end of table.

TABLE I. Group A inspection - Continued.

Inspection 1/	MIL-STD-750		Symbol	Limit		Unit
	Method	Conditions		Min	Max	
<u>Subgroup 2</u> - Continued						
Emitter to base cutoff current	3061	Bias condition D; $V_{EB} = 6 \text{ V dc}$, $I_C = 0$	I_{EBO1}		0.5	$\mu\text{A dc}$
Emitter to base cutoff current	3061	Bias condition D; $V_{EB} = 8 \text{ V dc}$, $I_C = 0$	I_{EBO2}		10	$\mu\text{A dc}$
Forward current transfer ratio 2N3418, 2N3418S 2N3419, 2N3419S 2N3420, 2N3420S 2N3421, 2N3421S	3076	$V_{CE} = 2 \text{ V dc}$; $I_C = 100 \text{ mA dc}$, pulsed (see 4.5.1)	h_{FE1}	20		
Forward current transfer ratio 2N3418, 2N3418S 2N3419, 2N3419S 2N3420, 2N3420S 2N3421, 2N3421S	3076	$V_{CE} = 2 \text{ V dc}$; $I_C = 1.0 \text{ A dc}$, pulsed (see 4.5.1)	h_{FE2}	20	60	
Forward current transfer ratio 2N3418, 2N3418S 2N3419, 2N3419S 2N3420, 2N3420S 2N3421, 2N3421S	3076	$V_{CE} = 2 \text{ V dc}$; $I_C = 2 \text{ A dc}$, pulsed (see 4.5.1)	h_{FE3}	15		
Forward current transfer ratio 2N3418, 2N3418S 2N3419, 2N3419S 2N3420, 2N3420S 2N3421, 2N3421S	3076	$V_{CE} = 5 \text{ V dc}$; $I_C = 5 \text{ A dc}$, pulsed (see 4.5.1)	h_{FE4}	10		
Base-emitter voltage (saturated)	3066	Test condition A; $I_C = 1.0 \text{ A dc}$, $I_B = 0.1 \text{ A dc}$, pulsed (see 4.5.1)	$V_{BE(sat)1}$ <u>6/</u>	0.6	1.2	V dc
Base-emitter voltage (saturated)	3066	Test condition A; $I_C = 2.0 \text{ A dc}$, $I_B = 0.2 \text{ A dc}$, pulsed (see 4.5.1)	$V_{BE(sat)2}$ <u>6/</u>	0.7	1.4	V dc
Saturation voltage and resistance (collector-emitter)	3071	$I_C = 1.0 \text{ A dc}$, $I_B = 0.1 \text{ A dc}$, pulsed (see 4.5.1)	$V_{CE(sat)1}$ <u>6/</u>		0.25	V dc
Saturation voltage and resistance (collector-emitter)	3071	$I_C = 2.0 \text{ A dc}$, $I_B = 0.2 \text{ A dc}$, pulsed (see 4.5.1)	$V_{CE(sat)2}$ <u>6/</u>		0.5	V dc

See footnotes at end of table.

MIL-PRF-19500/393D

TABLE I. Group A inspection - Continued.

Inspection 1/	MIL-STD-750		Symbol	Limit		Unit
	Method	Conditions		Min	Max	
<u>Subgroup 3</u>						
High-temperature operation:		$T_A = +150^\circ\text{C}$				
Collector to emitter cutoff current	3041	Bias condition A; $V_{BE} = -0.5\text{ V dc}$	I_{CEX2}			
2N3418, 2N3418S 2N3420, 2N3420S		$V_{CE} = 80\text{ V dc}$			50	$\mu\text{A dc}$
2N3419, 2N3419S 2N3421, 2N3421S		$V_{CE} = 120\text{ V dc}$			50	$\mu\text{A dc}$
Low-temperature operation:		$T_A = -55^\circ\text{C}$				
Forward current transfer ratio	3076	$V_{CE} = 2\text{ V dc}$, $I_C = 1\text{ A dc}$ pulsed (see 4.5.1)	h_{FE5}	10		
<u>Subgroup 4</u>						
Small-signal short-circuit forward-current transfer ratio magnitude of common emitter)	3306	$V_{CE} = 10\text{ V dc}$; $I_C = 0.1\text{ mA dc}$; $f = 20\text{ MHz}$	$ h_{fe} $	1.3	8	
Open-circuit output capacitance	3236	$V_{CB} = 10\text{ V dc}$, $I_E = 0$, $100\text{ kHz} \leq f \leq 1\text{ MHz}$	C_{obo}		150	pF
Switching time		$I_C = 1.0\text{ A dc}$, $I_{B(1)} = 100\text{ mA dc}$, $I_{B(2)} = -100\text{ mA dc}$, $V_{BE(off)} = -3.7\text{ V dc}$, $R_L = 20\ \Omega$, see figure 5	t_r t_d t_s t_f t_{off}		0.22 0.08 1.10 0.20 1.20	μs μs μs μs μs
<u>Subgroup 5</u>						
Safe operating area (continuous dc)	3051	$T_C = +100^\circ\text{C}$, $t \geq 1\text{ s}$, 1 cycle, see figure 6				
Test 1		$I_C = 3\text{ A dc}$, $V_{CE} = 5\text{ V dc}$				
Test 2		$I_C = 0.4\text{ A dc}$, $V_{CE} = 37\text{ V dc}$				
Test 3						
2N3418, 2N3418S 2N3420, 2N3420S		$I_C = 0.185\text{ A dc}$, $V_{CE} = 60\text{ V dc}$				
2N3419, 2N3419S 2N3421, 2N3421S		$I_C = 0.12\text{ A dc}$, $V_{CE} = 80\text{ V dc}$				

See footnotes at end of table.

MIL-PRF-19500/393D

TABLE I. Group A inspection - Continued.

Inspection <u>1/</u>	MIL-STD-750		Symbol	Limit		Unit
	Method	Conditions		Min	Max	
<u>Subgroup 5 - Continued</u> Safe operating area (clamped switching) Electrical measurements <u>Subgroup 6 and 7</u> Not applicable	3053	$T_A = +25^\circ\text{C}$, $I_B = 0.5 \text{ A dc}$, $I_C = 3.0 \text{ A dc}$, see figure 7 See group A, subgroup 2 herein				

1/ For sampling plan see MIL-PRF-19500.

2/ For resubmission of failed subgroup A1, double the sample size of the failed test or sequence of tests. A failure in group A, subgroup 1 shall not require retest of the entire subgroup. Only the failed test shall be rerun upon submission.

3/ Separate samples may be used.

4/ Not required for JANS devices.

5/ Not required for laser marked devices.

6/ Measured at a point on the leads no further than .125 inch (3.18 mm) from the case.

MIL-PRF-19500/393D

TABLE II. Group E inspection (all quality levels) - for qualification only.

Inspection	MIL-STD-750		Qualification
	Method	Conditions	
<u>Subgroup 1</u>			12 devices c = 0
Temperature cycling (air to air)	1051	Test condition C, 500 cycles	
Hermetic seal Fine leak Gross leak	1071		
Electrical measurements		See group A, subgroup 2.	
<u>Subgroup 2</u>			45 devices c = 0
Intermittent life	1037	Intermittent operation life: $V_{CB} = 10$ V dc.	
Electrical measurements		See group A, subgroup 2.	
<u>Subgroups 3, 4, and 5</u>			
Not applicable			

MIL-PRF-19500/393D

TABLE III. Groups B and C delta measurements. 1/ 2/ 3/

Step	Inspection	MIL-STD-750		Symbol	Limits		Unit
		Method	Conditions		Min	Max	
1.	Forward-current transfer ratio	3076	$V_{CE} = 2 \text{ V dc}$ $I_C = 1.0 \text{ A dc}$ pulsed (see 4.5.1)	Δh_{FE2} <u>1/</u>		+20 percent, -10 percent change from initial group A reading	
2.	Collector to emitter cutoff current	3041	Bias condition A; $V_{BE} = -0.5 \text{ V dc}$	ΔI_{CEX1} <u>1/</u>		100 percent of initial value or 100 nA dc, which- ever is greater	
	2N3418, 2N3418S 2N3420, 2N3420S		$V_{CE} = 80 \text{ V dc}$				
3.	Saturation voltage and resistance (collector-emitter)	3071	$I_C = 1.0 \text{ A dc}$, $I_B = 0.1 \text{ A dc}$, pulsed (see 4.5.1)	$\Delta V_{CE(sat)1}$ <u>1/</u>		±50 mV dc change from previously measured value	
	2N3419, 2N3419S 2N3421, 2N3421S		$V_{CE} = 120 \text{ V dc}$				

1/ The delta measurements for table VIa (JANS) of MIL-PRF-19500 are as follows:

- a. Subgroup 4, see table III herein, steps 1 and 3.
- b. Subgroup 5, see table III herein, steps 1, 2, and 3.

2/ The delta measurements for 4.4.2.2 (JAN, JANTX, JANTXV) of MIL-PRF-19500 are as follows: Steps 1, 2, and 3 of table III herein, after each step in 4.4.2.2.

3/ The delta measurements for table VII (JANS) of MIL-PRF-19500 are as follows: Subgroups 2, 3, and 6, see table III herein, steps 1, 2, and 3.

MIL-PRF-19500/393D

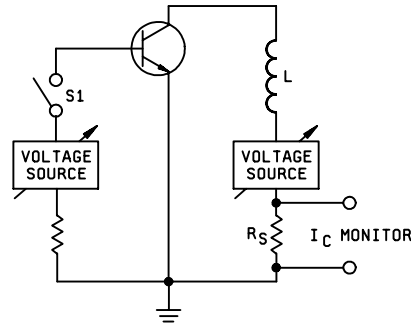

NOTES:

$R_S \leq 1.0 \Omega$ (noninductive), $L = 10 \text{ mH}$

Procedure:

1. With switch S_1 closed, set the specified test conditions.
2. Open S_1 .
3. Perform specified end-point tests.

FIGURE 4. Unclamped inductive sweep test circuit diagram.

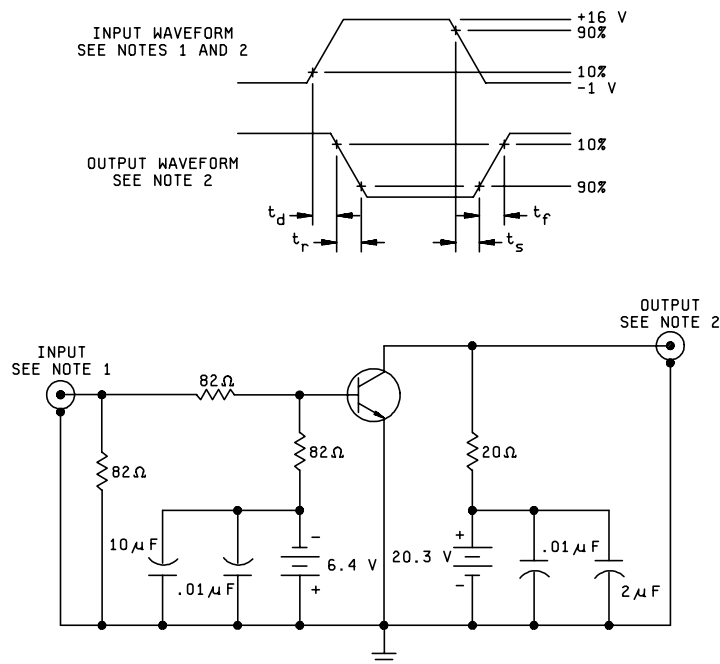

NOTES:

1. The input waveform is supplied by a pulse generator with the following characteristics:
 $t_r \leq 15 \text{ ns}$, $t_f \leq 15 \text{ ns}$, $Z_{OUT} = 50 \Omega$, $PW = 2 \mu\text{s}$, duty cycle ≤ 2 percent.
2. Output waveforms are monitored by an oscilloscope with the following characteristics:
 $t_r \leq 15 \text{ ns}$, $R_{in} \geq 10 \text{ M}\Omega$, $C_{in} \leq 11.5 \text{ pF}$.
3. Resistors shall be noninductive types.
4. The DC power supplies may require additional by-passing in order to minimize ringing.

FIGURE 5. Pulse response test circuit.

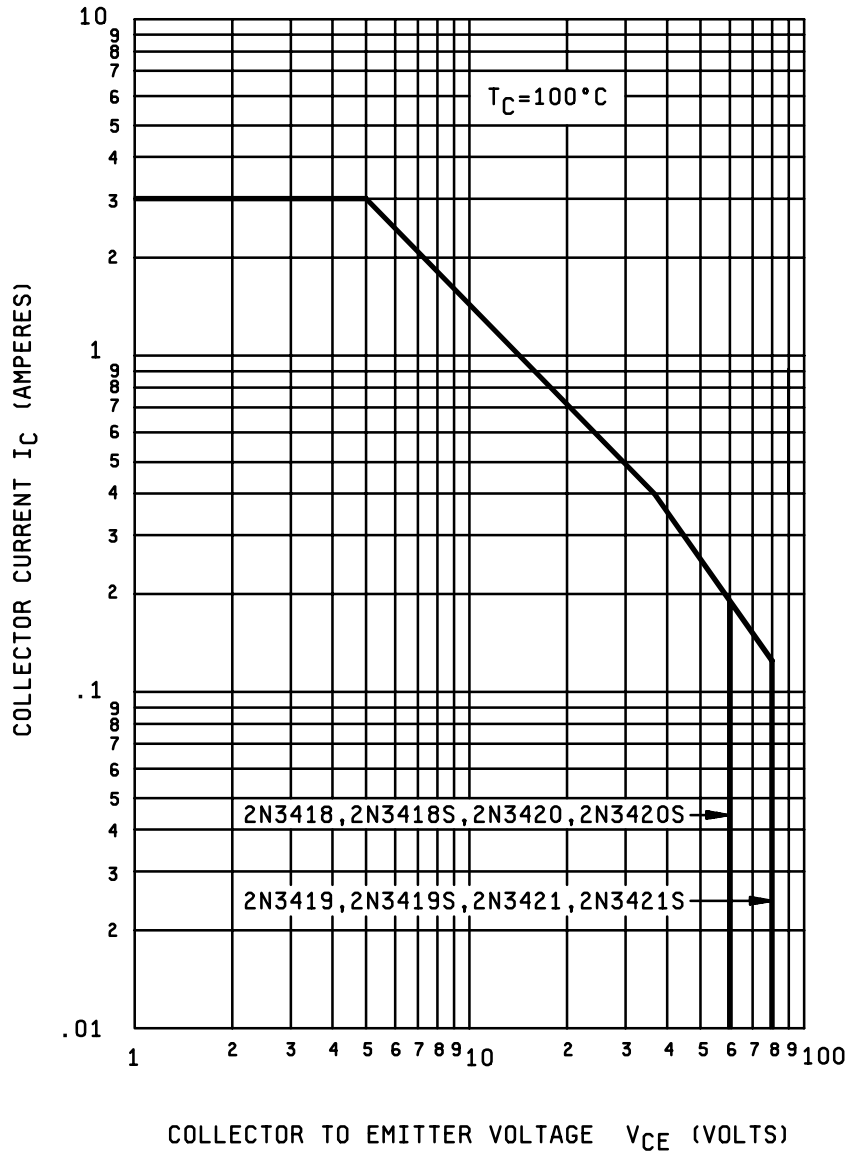
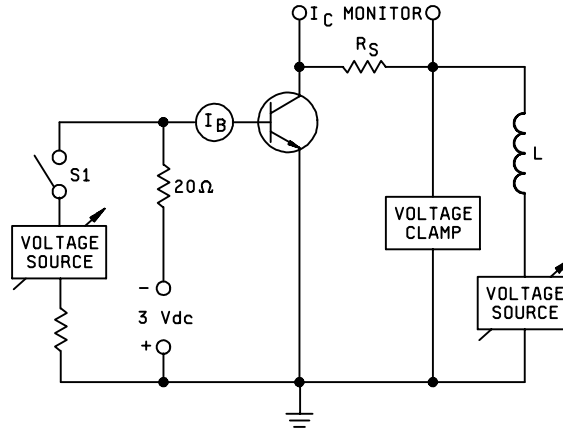

FIGURE 6. Maximum safe operating region.



NOTES:

Voltage clamp: 2N3418, 2N2418S, 2N3420, 2N3420S = 85 V dc
 2N3419, 2N3419S, 2N3421, 2N3421S = 125 V dc

$R_S \leq 1.0 \Omega$ (noninductive), $L = 40 \text{ mH}$

Procedure:

1. With switch S₁ closed, set the specified test conditions.
2. Open S₁.
3. Perform specified end-point tests.

FIGURE 7. Clamped inductive sweep test circuit diagram.

5. PACKAGING

5.1 Packaging. For acquisition purposes, the packaging requirements shall be as specified in the contract or order (see 6.2). When actual packaging of materiel is to be performed by DoD personnel, these personnel need to contact the responsible packaging activity to ascertain requisite packaging requirements. Packaging requirements are maintained by the Inventory Control Point's packaging activity within the Military Department or Defense Agency, or within the Military Department's System Command. Packaging data retrieval is available from the managing Military Department's or Defense Agency's automated packaging files, CD-ROM products, or by contacting the responsible packaging activity.

6. NOTES

(This section contains information of a general or explanatory nature that may be helpful, but is not mandatory.)

6.1 Intended use. The notes specified in MIL-PRF-19500 are applicable to this specification.

6.2 Acquisition requirements. Acquisition documents must specify the following:

- a. Title, number, and date of this specification.
- b. Issue of DoDISS to be cited in the solicitation, and if required, the specific issue of individual documents referenced (see 2.2).
- c. Packaging requirements (see 5.1).
- d. Lead finish (see 3.4.1).

6.3. Suppliers of JANHC and JANKC die. The qualified JANHC and JANKC suppliers with the applicable letter version (example JANHCA2N5152) will be identified on the QML.

JANHC and JANKC ordering information		
PIN	Manufacturer	
	33178	43611
2N3418	JANHCA2N3418	JANHCB2N3418
2N3419	JANHCA2N3419	JANHCB2N3419
2N3420	JANKCA2N3420	JANKCB2N3420
2N3421	JANKCA2N3421	JANKCB2N3421
2N3418S	JANKCA2N3418S	JANKCB2N3418S
2N3419S	JANKCA2N3419S	JANKCB2N3419S
2N3420S	JANKCA2N3420S	JANKCB2N3420S
2N3421S	JANKCA2N3421S	JANKCB2N3421S

6.4 Qualification. With respect to products requiring qualification, awards will be made only for products which are, at the time of award of contract, qualified for inclusion in Qualified Manufacturers' List (QML) whether or not such products have actually been so listed by that date. The attention of the contractors is called to these requirements, and manufacturers are urged to arrange to have the products that they propose to offer to the Federal Government tested for qualification in order that they may be eligible to be awarded contracts or orders for the products covered by this specification. Information pertaining to qualification of products may be obtained from Defense Supply Center, Columbus, ATTN: DSCC/VQE, P.O. Box 3990, Columbus, OH 43216-5000.

6.5 Changes from previous issue. Marginal notations are not used in this revision to identify changes with respect to the previous issue due to the extensiveness of the changes.

Custodians:

Army - CR
Navy - NW
Air Force - 11
NASA - NA
DLA - CC

Preparing activity:

DLA - CC

(Project 5961-2388)

Review activities:

Army - AR, AV, MI
Navy - AS, CG, MC
Air Force - 19

STANDARDIZATION DOCUMENT IMPROVEMENT PROPOSAL

INSTRUCTIONS

1. The preparing activity must complete blocks 1, 2, 3, and 8. In block 1, both the document number and revision letter should be given.
2. The submitter of this form must complete blocks 4, 5, 6, and 7.
3. The preparing activity must provide a reply within 30 days from receipt of the form.

NOTE: This form may not be used to request copies of documents, nor to request waivers, or clarification of requirements on current contracts. Comments submitted on this form do not constitute or imply authorization to waive any portion of the referenced document(s) or to amend contractual requirements.

I RECOMMEND A CHANGE:	1. DOCUMENT NUMBER MIL-PRF-19500/393D	2. DOCUMENT DATE 25 May 2001
------------------------------	--	---------------------------------

3. **DOCUMENT TITLE**
SEMICONDUCTOR DEVICE, TRANSISTOR, NPN, SILICON POWER TYPES 2N3418, 2N3418S, 2N3419, 2N3419S, 2N3420, 2N3420S, 2N3421, 2N3421S JAN, JANTX, JANTXV, JANS, JANHC, and JANKC

4. NATURE OF CHANGE (Identify paragraph number and include proposed rewrite, if possible. Attach extra sheets as needed.)

5. REASON FOR RECOMMENDATION

6. SUBMITTER

a. NAME (Last, First, Middle initial)	b. ORGANIZATION	
c. ADDRESS (Include Zip Code)	d. TELEPHONE (Include Area Code) COMMERCIAL DSN FAX EMAIL	7. DATE SUBMITTED

8. PREPARING ACTIVITY

a. Point of Contact Alan Barone	b. TELEPHONE Commercial DSN FAX EMAIL 614-692-0510 850-0510 614-692-6939 alan_barone@dscclia.mil		
c. ADDRESS Defense Supply Center, Columbus ATTN: DSCC-VAC P.O. Box 3990 Columbus, OH 43216-5000	IF YOU DO NOT RECEIVE A REPLY WITHIN 45 DAYS, CONTACT: Defense Standardization Program Office (DLSC-LM) 8725 John J. Kingman, Suite 2533, Fort Belvoir, VA 22060-6221 Telephone (703) 767-6888 DSN 427-6888		