

2. APPLICABLE DOCUMENTS

2.1 Government specifications and standards. Unless otherwise specified, the following specifications and standards, of the issue listed in that issue of the Department of Defense Index of Specifications and Standards specified in the solicitation, form a part of this specification to the extent specified herein.

SPECIFICATION

MILITARY

MIL-M-38510 - Microcircuits, General Specification for

STANDARD

MILITARY

MIL-STD-883 - Test Methods and Procedures for Microelectronics.

(Copies of specifications, standards, handbooks, drawings, and publications required by manufacturers in connection with specific acquisition functions should be obtained from the contracting activity or as directed by the contracting officer.)

3. REQUIREMENTS

3.1 Item requirements. The individual item requirements shall be in accordance with MIL-M-38510, and as specified herein. The country of manufacture requirement of MIL-M-38510 does not apply.

3.2 Design, construction, and physical dimensions. The design, construction, and physical dimensions shall be as specified in MIL-M-38510 and herein.

3.2.1 Design documentation. The design documentation shall be in accordance with MIL-M-38510 and, unless otherwise specified in the contract or purchase order, shall be retained by the manufacturer but be available for review by the acquiring activity or contractor upon request.

3.2.2 Logic diagram and terminal connections. The logic diagram and terminal connections shall be as specified on figure 1.

3.2.3 Truth table. The truth table shall be as specified on figure 2.

3.2.4 Case outlines. The case outlines shall be in accordance with 1.2.2.

3.3 Lead material and finish. The lead material and finish shall be in accordance with MIL-M-38510.

3.4 Electrical performance characteristics. Unless otherwise specified, the electrical performance characteristics are as specified in table I and apply over the full recommended case operating temperature range.

3.5 Marking. Marking shall be in accordance with MIL-M-38510, except the part number shall be in accordance with 1.2 herein. The Vendor Similar Part Number may also be marked in accordance with 6.8 herein. Both part numbers, when used, shall be printed on the same surface. The "M38510/XXXXY" part number and the "JAN" or "J" mark shall not be used. Lead finish letter "X" is used only as specified in MIL-M-38510 and shall not be marked on the microcircuit or its packaging. The country of origin shall be marked on the microcircuit.

3.6 Quality assurance requirements. Microcircuits furnished under this drawing shall have been subjected to, and passed all the requirements, tests, and inspections detailed herein including screening and quality conformance inspections.

DEFENSE ELECTRONICS SUPPLY CENTER DAYTON, OHIO	SIZE	CODE IDENT. NO.	DWG NO.
	A	14933	84061
	REV	PAGE	3

TABLE I. Electrical performance characteristics.

Test	Symbol	Conditions ^{1/} -55°C ≤ T _C ≤ +125°C	Group A subgroups	Limits		Unit	
				Min	Max		
High level output voltage	V _{OH}	V _{CC} = 4.5 V I _{OH} = -1.0 mA	V _{IH} = 2.0 V V _{IL} = 0.8 V	1, 2, 3	2.4	---	V dc
Low level output voltage	V _{OL}	V _{CC} = 4.5 V I _{IN} = 12 mA	V _{IL} = 0.8 V V _{IH} = 2.0 V	1, 2, 3	---	0.4	V dc
Input clamp voltage	V _{IC}	V _{CC} = 4.5 V I _{IN} = -18 mA	T _C = +25°C	1	---	-1.5	V dc
Low level input current	I _{IL}	V _{CC} = 4.5 V I _{IN} = 0.4 V		1, 2, 3	0	-100	μA
High level input current	I _{IH1}	V _{CC} = 5.5 V V _{IN} = 2.7 V		1, 2, 3		20	μA
	I _{IH2}	V _{CC} = 5.5 V V _{IN} = 7.0 V		1, 2, 3		100	μA
Output current ^{1/}	I _O	V _{CC} = 5.5 V V _O = 2.25 V		1, 2, 3	-30	-112	mA
Supply current, outputs high	I _{CCH}	V _{CC} = 5.5 V		1, 2, 3		3	mA
Supply current, outputs low	I _{CCL}	V _{CC} = 5.5 V		1, 2, 3		12.0	mA
Propagation delay time low-to-high level	t _{PLH}	V _{CC} = 5.0 V C _L = 50 pF ±10% R _L = 500Ω	T _C = +25°C	9	1	7	ns
			T _C = +125°C and -55°C	10, 11	1	9	
Propagation delay time high-to-low level	t _{PHL}	V _{CC} = 5.0 V C _L = 50 pF ±10% R _L = 500Ω	T _C = +25°C	9	1	6	ns
			T _C = +125°C and -55°C	10, 11	1	8	

^{1/} The output conditions have been chosen to produce a current that closely approximates one half of the true short-circuit output current, I_{OS}.

DEFENSE ELECTRONICS SUPPLY CENTER DAYTON, OHIO	SIZE A	CODE IDENT. NO. 14933	DWG NO. 84061
		REV	PAGE 4

3.6.1 Screening. Screening shall be in accordance with method 5004, class B, of MIL-STD-883 and 4.2 herein.

3.6.2 Qualification. Qualification inspection for the device type specified herein shall not be required.

3.6.3 Quality conformance inspection. Quality conformance inspection shall be in accordance with MIL-M-38510 and 4.4 herein.

3.7 Manufacturer eligibility. To be eligible to supply microcircuits to this drawing, a manufacturer shall have manufacturer certification in accordance with MIL-M-38510 for at least one line and have part I listing on Qualified Products List QPL-38510 for at least one device type (not necessarily the one for which the acquisition of this drawing is to apply).

3.8 Certificate of compliance. A certificate of compliance shall be required from a manufacturer in order to be listed as an approved source of supply (see 6.7 and 6.8).

4. QUALITY ASSURANCE PROVISIONS

4.1 Sampling and inspection. Sampling and inspection procedures shall be in accordance with MIL-M-38510 and method 5005 of MIL-STD-883, except as modified herein.

4.2 Screening. Screening shall be in accordance with method 5004 of MIL-STD-883, and shall be conducted on all devices prior to quality conformance inspection. The following additional criteria shall apply:

a. Burn-in test (method 1015 of MIL-STD-883).

(1) Test condition A, B, C, or D.

(2) $T_A = +125^\circ\text{C}$, minimum.

b. Interim and final electrical test parameters shall be as specified in table II herein, except interim electrical parameter tests prior to burn-in are optional at the discretion of the manufacturer.

c. The percent defective allowable (PDA) shall be as specified in MIL-M-38510.

4.3 Qualification inspection. Qualification inspection for the device type specified herein shall not be required.

4.4 Quality conformance inspection. Quality conformance inspection shall be in accordance with MIL-M-38510 and method 5005 of MIL-STD-883. Groups A and B inspections shall be performed on each inspection lot or as specified in method 5005 of MIL-STD-883. Groups C and D shall be performed on a periodic basis in accordance with MIL-M-38510. Generic test data (see 6.5) may be used to satisfy the requirements for groups C and D inspections. Manufacturers shall keep lot records for 3 years (minimum), monitor for compliance to the prescribed procedures, and observe that satisfactory manufacturing conditions and records on lots are maintained for these devices. The records, including, as a minimum, an attributes summary of all screening and quality conformance inspections conducted on each lot shall be available for review by customers at all times.

DEFENSE ELECTRONICS SUPPLY CENTER DAYTON, OHIO	SIZE A	CODE IDENT. NO. 14933	DWG NO. 84061
		REV	PAGE 5

TABLE II. Electrical test requirements.

MIL-STD-883 test requirements	Subgroups (per method 5005, table I)
Interim electrical parameters (pre burn-in) (method 5004)	---
Final electrical test parameters (method 5004)	1*, 2, 3, 7, 9
Group A test requirements (method 5005)	1, 2, 3, 9
Groups C and D end-point electrical parameters (method 5005)	1, 2, 3
Additional electrical subgroups for group C periodic inspections	10, 11**

- * PDA applies to subgroup 1 (see 4.2c).
- ** Subgroups 10 and 11, if not tested, shall be guaranteed to the specified limits in table I.

4.4.1 Group A inspection. Group A inspection shall consist of the test subgroups and LTPD values shown in table I of method 5005 of MIL-STD-883, class B, and as follows:

- a. Tests shall be as specified in table II herein.
- b. Subgroups 4, 5, 6, and 8 in table I, method 5005 of MIL-STD-883 shall be omitted.

4.4.2 Group B inspection. Group B inspection shall consist of the test subgroups and LTPD values shown in table Iib of method 5005 of MIL-STD-883, class B.

4.4.3 Groups C and D inspections. Groups C and D inspections shall consist of the test subgroups and LTPD values shown in tables III and IV, method 5005 of MIL-STD-883, class B, and as follows:

- a. End-point electrical parameters shall be as specified in table II herein.
- b. Steady-state life test (method 1005 of MIL-STD-883) conditions:
 - (1) Test condition A, B, C, or D.
 - (2) $T_A = +125^\circ\text{C}$, minimum.
 - (3) Test duration: 1,000 hours, except as permitted by appendix B of MIL-M-38510 and method 1005 of MIL-STD-883.
- c. Subgroups 3 and 4 shall be added to group C inspection requirements and shall consist of the tests, conditions, and limits specified for subgroups 10 and 11 of group A.

DEFENSE ELECTRONICS SUPPLY CENTER DAYTON, OHIO	SIZE A	CODE IDENT. NO. 14933	DWG NO. 84061
		REV	PAGE 6

CASES A, B, C, AND D

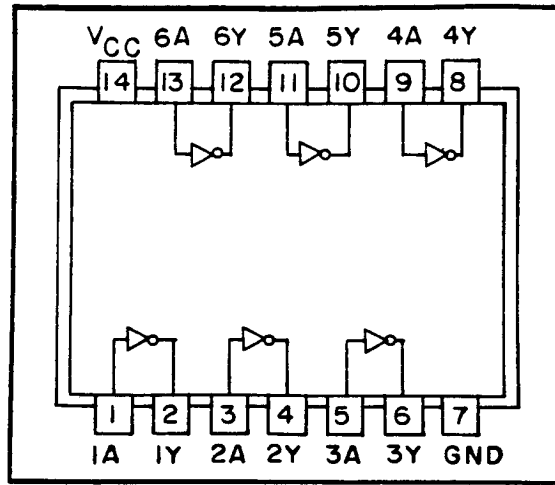

CASE 2

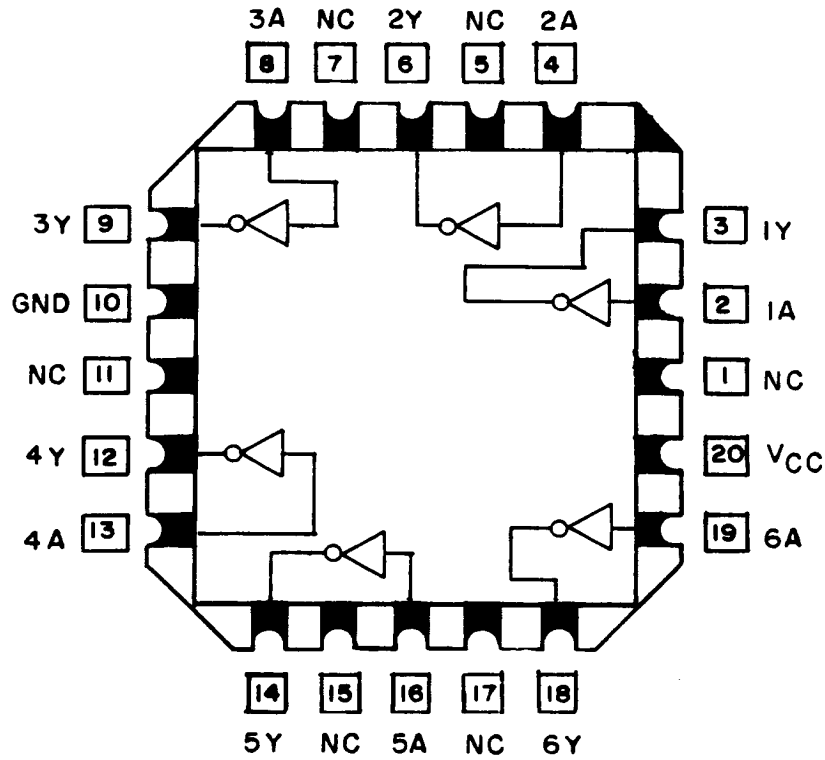

FIGURE 1. Logic diagram and terminal connections (top view).

DEFENSE ELECTRONICS SUPPLY CENTER DAYTON, OHIO	SIZE A	CODE IDENT. NO. 14933	DWG NO. 84061
		REV	PAGE 7

TRUTH TABLE EACH GATE	
INPUT	OUTPUT
A	Y
L	H
H	L

$$Y = \bar{A}$$

FIGURE 2. Truth table and logic equation.

DEFENSE ELECTRONICS SUPPLY CENTER DAYTON, OHIO	SIZE A	CODE IDENT. NO. 14933	DWG NO. 84061
		REV	PAGE 8

5. PACKAGING

5.1 Packaging requirements. The requirements for packaging shall be in accordance with MIL-M-38510.

6. NOTES

6.1 Notes. Only the note "Reevaluation of lot quality" of the notes specified in MIL-M-38510, section 6, shall apply to this drawing.

6.2 Intended use. Microcircuits conforming to this drawing are intended for use when military specifications do not exist and qualified military devices that will perform the required function are not available for OEM application. This drawing is intended exclusively to prevent the proliferation of unnecessary duplicate specifications, drawings, and stock catalog listings. When a military specification exists and the product covered by this drawing has been qualified for listing on QPL-38510, this drawing will be inactivated and will not be used for new design. The QPL-38510 product shall be the preferred item for all applications.

6.3 Ordering data. The contract or purchase order should specify the following:

- a. Complete part number (see 1.2).
- b. Requirements for delivery of one copy of the quality conformance inspection data pertinent to the device inspection lot to be supplied with each shipment by the device manufacturer, if applicable.
- c. Requirements for certificate of compliance, if applicable.
- d. Requirements for notification of change of product or process to the contracting activity, if applicable.
- e. Requirements for special carriers, lead lengths, or lead forming, if applicable. These requirements shall not affect the part number. Unless otherwise specified, these requirements will not apply to direct shipment to the Government.

6.4 Replaceability. Replaceability is determined as follows:

- a. Microcircuits covered by this drawing will replace the same generic device covered by a contractor-prepared specification or drawing.
- b. When a QPL source is established, the part numbered device specified in this drawing will be replaced by the microcircuit identified as part number M38510/38409BXX.

6.5 Generic test data. Generic test data may be used to satisfy the requirements of 4.4.3. Group C generic test data shall be on date codes no more than 1 year old and on a die in the same microcircuit group (see appendix E of MIL-M-38510) with the same material, design and process and from the same plant as the die represented. Group D generic data shall be on date codes no more than 1 year old and on the same package type (see terms, definitions, and symbols of MIL-M-38510) and from the same plant as the package represented. The vendor is required to retain the generic data for a period of not less than 36 months from the date of shipment.

6.6 Comments. Comments on this drawing should be directed to DESC-ECS, Dayton, Ohio 45444, or telephone 513-296-5375.

DEFENSE ELECTRONICS SUPPLY CENTER DAYTON, OHIO	SIZE A	CODE IDENT. NO. 14933	DWG NO. 84061
		REV	PAGE 9

6.7 Submission of certificate of compliance. The certificate of compliance submitted to DESC-ECS, prior to Listing as an approved source of supply in 6.8, shall state that the manufacturer's product meets the requirements herein.

6.8 Approved sources of supply. An approved source of supply is listed herein. Additional sources will be added as they become available. The vendor listed herein has agreed to this drawing and a certificate of compliance (see 3.8) has been submitted to DESC-ECS.

DESC drawing part number	Vendor FSCM number	Vendor similar part number	Replacement military specification part number
8406101BX	01295	SNJ54ALS1004WA	MIL-M 38510/384098BX
8406101CX	01295	SNJ54ALS1004J	MIL-M-38510/384098CX
8406101DX	01295	SNJ54ALS1004W	MIL-M-38510/384098DX
84061012X	01295	SNJ54ALS1004FK	MIL-M-38510/3840982X

Vendor FSCM number

01295

Vendor name and address

Texas Instruments, Inc.
P.O. Box 6448
Midland, Texas 79701

DEFENSE ELECTRONICS SUPPLY CENTER DAYTON, OHIO	SIZE A	CODE IDENT. NO. 14933	DWG NO. 84061
		REV	PAGE 10

DESC FORM 144A
APR 83

014938 _ _ _