

# Model 85 5psi



**316L SS Pressure Sensor**  
**High Performance, Small Profile**  
**0-100 mV Output**  
**Absolute and Gage**  
**Low Pressure**

- ▶ Medical Instruments
- ▶ Process Control
- ▶ Oceanography
- ▶ Refrigeration/Compressors
- ▶ Pressure Transmitters
- ▶ Level Systems



## DESCRIPTION

This is a micromachined piezoresistive silicon pressure sensor. It is designed for OEM applications where compatibility with corrosive media must be maintained. The sensor chip is mounted on a TO style header, which is resistance welded to a 316 stainless steel package. A 316 stainless steel convoluted isolation diaphragm is welded to the package, sealing a small volume of silicone oil between the diaphragm and the sensor chip. The ISO pressure housing utilizes the oil column to couple the piezoresistive sensor to the isolation diaphragm. A thickfilm ceramic compensation board with laser trimmed resistors, and an additional gain set resistor to normalize pressure sensitivity are an integral part of the sensor package. A variety of threaded process fittings are available. Fittings include standards like 1/4 and 1/8 NPT, 1/4 BSP as well as custom process fittings. Electrical options include cable and connector.

## FEATURES

- ▶ Weldable and O-Ring Flush Mount
- ▶ 0°C to +50°C Compensated Temperature Range
- ▶ +0.1% Pressure Non-linearity
- ▶ +1.0% Interchangeable Span (provided by gain set resistor)
- ▶ Solid State Reliability
- ▶ Low Power

## STANDARD RANGES

Range	psig	psia
0 to 5	●	●

## DIMENSIONS

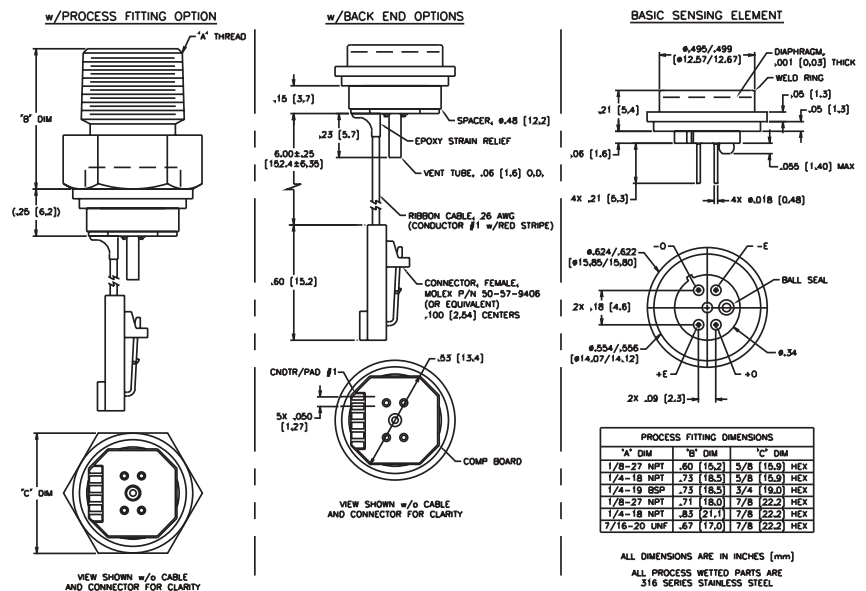

**PERFORMANCE SPECIFICATIONS**

All parameters measured at 1.5mA drive and at 25°C after 10 second warm up, unless otherwise specified. Unless specifically indicated, only those parameters indicated as tested are verified on each part. Parameters are specified for the compensated version only.

PARAMETERS	MIN	TYP	MAX	UNITS	NOTES
Full Scale Output Span	75	120	150	mV	1, 2
Zero Offset	-1	0	1	mV	2
Pressure Non-linearity	-0.10		0.10	% Span	3
Pressure Hysteresis	-0.1		0.1	% Span	
Input Resistance	3,500		6,000	$\Omega$	
Output Resistance	4000		25000	$\Omega$	
Temperature Error - Span	-0.75		0.75	% Span	4
Temperature Error - Zero	-1.5		1.5	% Span	4
Thermal Hysteresis - Span	-0.25		0.25	% Span	4
Thermal Hysteresis - Zero	-0.25		0.25	% Span	4
Long Term Stability - Offset		0.1		$\pm\%$ Span/yr.	
Long Term Stability - Span		0.1		$\pm\%$ Span/yr.	
Supply Current	0.5	1.5	2.0	mA	5
Output Load Resistance	5			M $\Omega$	6
Insulation Resistance (50 VDC)	50			M $\Omega$	7
Pressure Overload			3X	Rated	
Compensated Operating Temperature	0°C to 50°C				8
Operating Temperature Range	-40°C to +125°C				8
Storage Temperature Range	-50°C to +125°C				8
Media - Pressure Port	Liquids and Gases compatible with 316L Stainless Steel				
Media - Reference Port	Compatible with Silicon, Pyrex, Gold, Fluorosilicone Rubber and 316L Stainless Steel				
Weight	13 g				9

**Notes**

- For amplified output circuits, 3.012V  $\pm$  1% interchangeability with gain set resistor. See Application Note TN-003.
- Measured at vacuum for absolute (A), ambient for gage (G).
- Best fit straight line.
- Over Temperature range: 0°C to 50°C Span with respect to +25°C.
- Guarantees output/input ratiometricity.
- Load resistance to reduce measurement errors due to output loading.
- Between case and sensing element.
- Maximum temperature range for product with standard cable and connector is -20°C to +105°C.
- Weight depends upon configuration (cable, connector, pressure fitting).
- For gage units used at pressures below atmosphere, the span accuracy is not guaranteed.

**ORDERING INFORMATION**

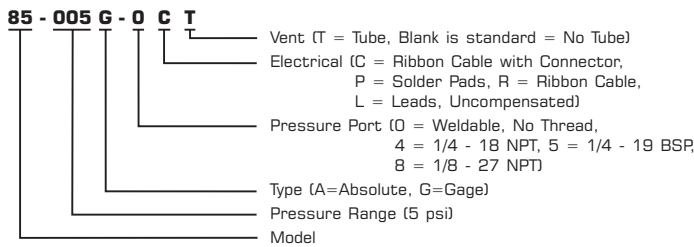

**CONNECTIONS**

PAD NO. / CABLE	FUNCTION
1	+OUT
2	-EX
3	+EX
4	-OUT
5	GAIN
6	GAIN

**APPLICATION SCHEMATIC**

